

We touch your **electricity** everyday!

Directional Power Relay

## Hi-Tech Range IRP-V3



OVER  
POWER  
PROTECTION

UNDER  
POWER  
PROTECTION

REVERSE  
POWER  
PROTECTION

CATALOG



**PMD Division**

**CONTENTS**

S.No.	Description	Page No.
1.0	Introduction & Application	03
2.0	Protection Features	03
3.0	Hardware	03
4.0	Protection Functions	03
5.0	Fault Record	04
6.0	Hardware & Case	05
7.0	Human Machine Interface	05
8.0	Calculation of the adjustment value Necessary Data	06
9.0	Technical Data	07
10.0	Setting Ranges	08
11.0	Standards	09
12.0	Connection Diagram	10
13.0	Terminal Arrangement	11
14.0	Terminal Description	11
15.0	Dimension Details	12
16.0	Panel Cut out Details	12
17.0	Ordering Information	13



## 1.0 Introduction & Application

IRP protection relays are based on microprocessor technology and used for monitoring and protection applications based on active power. The following features of the IRP relays are:

- Integration of multiple protection function into one compact housing
- User friendly HMI
- Compact design due to SMD technique
- Measurement & Protection
- DO Matrix Programmability
- Last 5 fault records (non-volatile memory)

The directional power relay IRP is used for reverse power or forward active power supervision in low voltage and medium voltage systems. The load is measured in one phase only on assumption that the phases are loaded symmetrically.

Among other applications the relay can be used as directional power relay for protection against reverse power or forward power of Turbo generators and Diesel generating sets if prime mover fails. For the generator operating in parallel with a mains or another generator, it is imperative to supervise the power direction. If for example the prime mover fails the alternator operate as a motor and drive the prime mover (Diesel Engine/Turbine). The IRP recognises the power direction and switches off the alternator. This way, power losses and damages to the prime mover are avoided.

## 2.0 Protection Features

- Under / Over Power Protection in forward direction
- Reverse Power Protection (32)

## 3.0 Hardware

- 1 Voltage Analog Input
- 1 Current Analog Input
- Max. 3 Digital Outputs
- Indication LEDs for pickup & trip
- Bright Alpha numeric (12x2) LCD
- 3 Push buttons on the front for HMI operations

## 4.0 Protection Functions

### Power Protection

The relay is equipped with an independent, over ( $P>$ ) and under ( $P<$ ) forward power supervision simultaneously with separately adjustable tripping values and delay times.

The highest power is always evaluated for over power supervision and the lowest power for under power supervision. When the set value for under power is crossed once after that if power goes down to the set value than under power is detected.

### Output Trip Contact

The IRP is provided with three tripping relay (DO). All three relays (DOs) can be configure to any fault through relay assignment menu (DO Matrix) of HMI.

Relay reset operation can be configurable in automatic reset or manual reset mode from HMI (Human machine interface).

In automatic reset mode relay will be reset after the power goes above/below the pick-up level for Under/Over power. In manual mode relay will be reset by pressing reset button.

## Power Protection

### Front Plate

At the front of the relay following operating and indicating elements are arranged:

3 push switches for set values of normal tripping characteristics including a RESET/ENTER push switch.

4 LEDs for indicating faults and readiness to operate.

LCD display to display settings and running values etc.

The RESET switch is provided for acknowledgment and reset of the fault LEDs/Relay.

The 4 LED on the front plate of IRP have following functions:

LED P> indicates Pickup/Fault due to Over Power in forward direction.

LED P< indicates Pickup/Fault due to Under Power in forward direction.

LED Pr> indicates Pickup/Fault due to Reverse Power.

LED TRIP indicates Relay Tripping.

### Measurements

Following parameters will be measured / displayed on the LCD screen continuously

- 1) Active Power
- 2) Voltage
- 3) Current

## 5.0 Fault Record

The IRP-V3 relay can store the last 5 faults that have occurred in non-volatile memory. Fault1 is the latest fault.

Each record provides the following information:

Magnitude of Active Power, Voltage, Current

Fault Type

### 6.0 Hardware & Case



All the models of the IRP range have a plastic IP54 protected case, and can be flush-mounted in switchboard or panel. External connections are made via Barrier terminal blocks. Each terminal connection is suitable for 8mm ring type lugs with M3.5 screw fixing.

### 7.0 Human Machine Interface

The user interface for IRP-V3 comprises :

It comprises of

- 12x2 LCD display for measurement and setting display
- Three push switches for Edit set values and RESET / ENTER
- Four LEDs to provide information such as PICKUP, TRIP etc.

Keys	Manual Key
	used as ENTER key in Edit / Setting / View menu
	Long press to enter in Edit menu
	used as Fault RESET/ acknowledgment key with single press
	is used to scroll or edit parameters
	is used to scroll or edit parameters

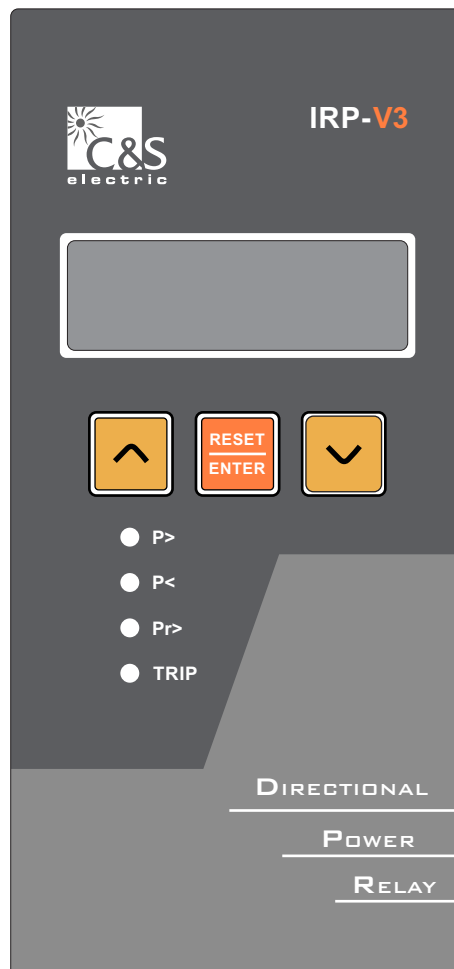

## 8.0 Calculation Example of Setting Value :

IRP-V3 measures the power in one phase only. The power is assume to be symmetrical. Lets consider the Generator application

Required data :

$P_{GEN}$ [kW]	Rated Active Power of the generator in kW, it is calculated from the apparent power of the generator $S_{GEN}$ according to $P_{GEN} = S_{GEN} \cos \emptyset$ Where $\cos \emptyset$ = Rated Generator Power Factor
$I_n$	Rated Current of the relay
$U_n$	Rated voltage of the relay
$n_i$	Ratio of the current transformer
$n_u$	Ratio of the voltage transformer

Should the relay, for instance, trip at a generator re-verse power of 10 %, this does not mean that the set-ting value of the IRP-V3 is 10 %. Based on the trans-former transformation ratio (If applicable), the setting point has to be calculated.

### Calculated Example

#### 3 Phase, 4 Wire with current transformer

Active Power of the generator in kW it is calculated from the Apparent power of the generator  $S_{GEN}$  according to

$$\begin{aligned}
 P_{GEN} &= 625 \text{ kVA} \times 0.8 &= 500 \text{ kW} \\
 \text{Nominal current of IRP } (I_n) &= 5 \text{ A} \\
 \text{Nominal voltage of IRP } (U_n) &= 110 \text{ V} \\
 \text{Current Transformer Ratio } (n_i) &= 1000 \text{ A} / 5 \text{ A} = 200 \\
 \text{Voltage Transformer ratio } (n_u) &= \text{Not used}
 \end{aligned}$$

When the relay is expected to trip at a generator reverse power of 5%, calculation of the set-ting value  $Pr>$  is as follows:

$$Pr> (\%) = \frac{\frac{500 \text{ kW}}{3 \times 1 \times 200}}{110 \times 5} \times 5\% = 7.5\% = 7\%$$

According to the above example, the IRP-V3 has to be set to 7% so that it trips at a generator reverse power of 5% (rated generator active power).

9.0 Technical Data

Parameter	Description
Rated Voltage	110V / 230V / 415V (Model Dependent)
Rated Current	1 / 5 Amp (Model Dependent)
Frequency Range	50 Hz $\pm$ 2.5Hz
Measurement Accuracy	Active Power : $\pm$ 2.5% (Power Range : 2 - 150% Pn) at Rated frequency
Trip Time Accuracy	$\pm$ 5% (or $\pm$ 100 mSec) (which ever is higher)
Protection	Over Power , Under Power, Reverse Power
Display	
LCD Display	Metering and Fault information
LED	P>, P<, Pr>, TRIP
Auxiliary Supply <small>(Refer Ordering Information)</small>	L: 18-60V DC / H: 85-280V AC / 100-300V DC
Output Relay Contact (DO)	1 C/O + 2 N/O Contacts
DO Contact	1 C/O Contact - N/O contact, 5A / 250V AC or 30V DC (Resistive Load) ; N/C contact, 2A / 250V AC or 30V DC (Resistive Load) 2 N/O Contact with separate common, 5A / 250V AC or 30V DC (Resistive Load)
DO Reset	Automatic / Manual (HMI Selectable)
Mounting	Panel mount
Temperature Operation	0°C to 70°C
Temperature Storage	-10°C to 85°C
Wiring Connection	Screwed Terminal
Dimension	Please refer "Dimension Details"

## 10.0 Setting Ranges

### Protection Setting

Parameters	Display	Setting Range		Step Size	Default Setting
		Min	Max		
Under Power pickup setting	P<	2%Pn	100%Pn	1%	OFF
Under Power definite time	P<td	0.2 sec	200.0 sec	0.1 sec	0.5 sec
Over Power pickup setting	P>	2%Pn	150%Pn	1%	110%Pn
Over Power definite time	P>td	0.2 sec	200.0 sec	0.1 sec	0.5 sec
Reverse Power pickup setting	Pr>	2%Pn	100%Pn	1%	10%Pn
Reverse Power definite time	Pr>td	0.2 sec	200.0 sec	0.1 sec	0.5 sec

**Note:** All the protection settings are available with DISABLE (OFF) option.

### Common Setting

Parameters	Display	Setting Range		Step Size	Default Setting
		Min	Max		
Nominal Frequency	Freq	50 Hz	60 Hz	-	50 Hz
CT Ratio	CTratio	1	6500	1	1
PT Ratio	PTratio	1	1000	1	1
Connection <sup>(1)</sup>	Conectn	L-N	L-L	-	L-N
Over Power DO Reset	OvPDORst	MAN	ATO	-	MAN
Under Power DO Reset	UnPDORst	MAN	ATO	-	MAN
Reverse Power DO Reset	RvPDORst	MAN	ATO	-	MAN
Under Power Detection Level <sup>(2)</sup>	P<lvl	5%Pn	110%Pn	1%	OFF

**Note:** <sup>(1)</sup>Please Refer Connection Diagram to Set this value.

<sup>(2)</sup>When this setting in ENABLED, Under power pickup detection will start once active power goes above this limit value & then comes below under power protection setting. Hence this setting has to be more than under power protection setting.

### DO Assignment (DO Matrix)

Parameters	Display
Under Power protection	P<
Over Power protection	P>
Reverse Power protection	Pr>
Self Supervision	Self

**Note:** DO Assignment for 3 Nos of DO (Relay Contact).

### General Data

Rated Auxiliary Voltage (UH)	L : (18 - 60V DC)
	H : (85 - 280V AC / 100 - 300V DC)
Power consumption on Aux supply	Quiescent approx. 1.6W ; Operating approx. 2.0W
VA Burden (Current measurement)	<1VA @1A/5A
VA Burden (Voltage measurement)	<1VA @110/230/415 V
DO Contact Rating (Potential Free)	1 C/O Contact N/O contact, 5A / 250V AC or 30V DC (Resistive Load) ; N/C contact, 2A / 250V AC or 30V DC (Resistive Load) 2 N/O Contact with 1 common, 5A / 250V AC or 30V DC (Resistive Load)

**Measuring Input**

Rated Data	Rated current I <sub>p</sub> :1A or 5A
	Rated frequency F <sub>n</sub> : 50 Hz
Drop out to Pickup Ratio	>96%
DC Current Carrying Capacity	8A@30VDC / 0.3A@110VDC/ 0.2A@220VDC
Power consumption in current circuit	At I <sub>p</sub> =1A      0.2 VA
	At I <sub>p</sub> =5A      0.4 VA
Thermal withstand capacity in current circuit	Dynamic current withstand
	for 1 Sec      : 100 x I <sub>p</sub>
	for 10 Sec     : 30 x I <sub>p</sub>
	continuously    : 4 x I <sub>p</sub>
Protection-Front Panel	IP-54
Weight	Approx. 700 gms

**11.0 Standards**

Type Test	
Functional Tests	Internal Design Specifications & IEC 60255

Climatic Test	
Temperature Dry Cold	IEC 60068-2-1
Temperature Dry Heat	IEC 60068-2-2

Enclosure	
Enclosure	IEC 529

Mechanical	
Vibration response / Endurance test	IEC 60068-2-6
Shock Response / Withstand Test	IEC 60255-21-1

Electrical Test	
Insulation Resistance>100MΩ	IEC 60255-5
Supply Voltage	IEC 60255-6
Voltage Dips and Interruptions	IEC 1000-4-11
Dielectric Test (Relay de-energised)	IEC 60255-5
High Voltage Impulse (Relay de-energised)	IEC 60255-5

Electro-magnetic Compatibility	
Electrical fast Transient/Burst	IEC 61000-4-4
Electrostatic Discharge	IEC 61000-4-2
Conducted Susceptibility	IEC 61000-4-6
Radiated RF E-M field immunity test	IEC 61000-4-3
Surge Immunity	IEC 61000-4-5
Conducted & Radiated RF Interference Emission	CISPR 11

12.0 Connection Diagram

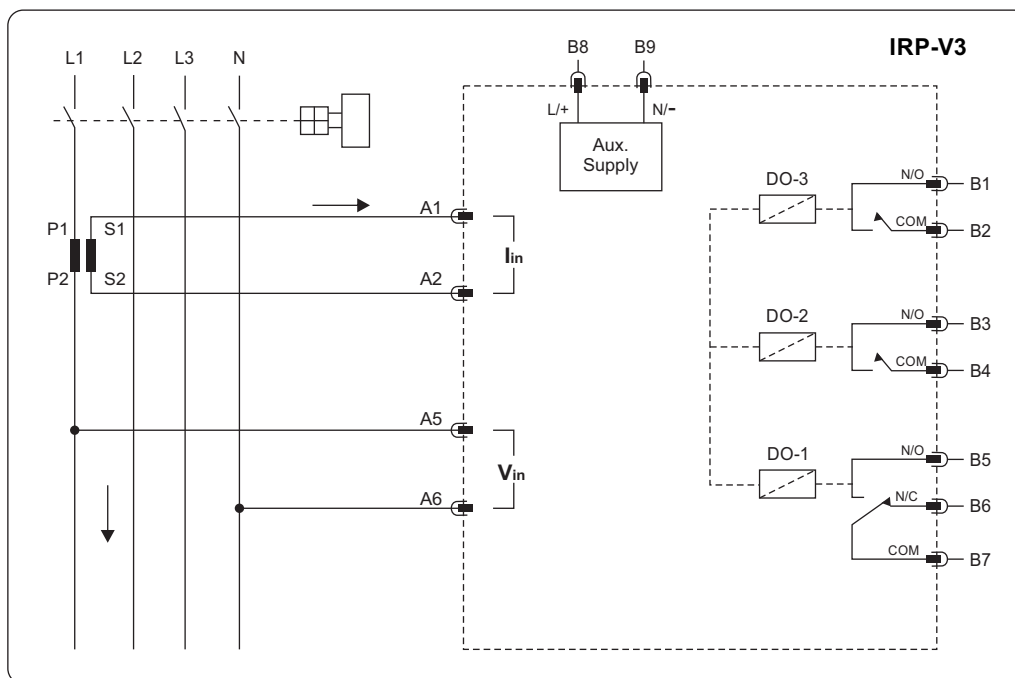

Connection Line to Neutral Voltage in 3 Phase, 4 Wire System (Default Connection)

NOTE:

- While connecting the relay, it is to be observed that the current transformer terminals k(s1) and l(s2) are connected
- Further the current and voltage measurement must be done on the same phase (L1).

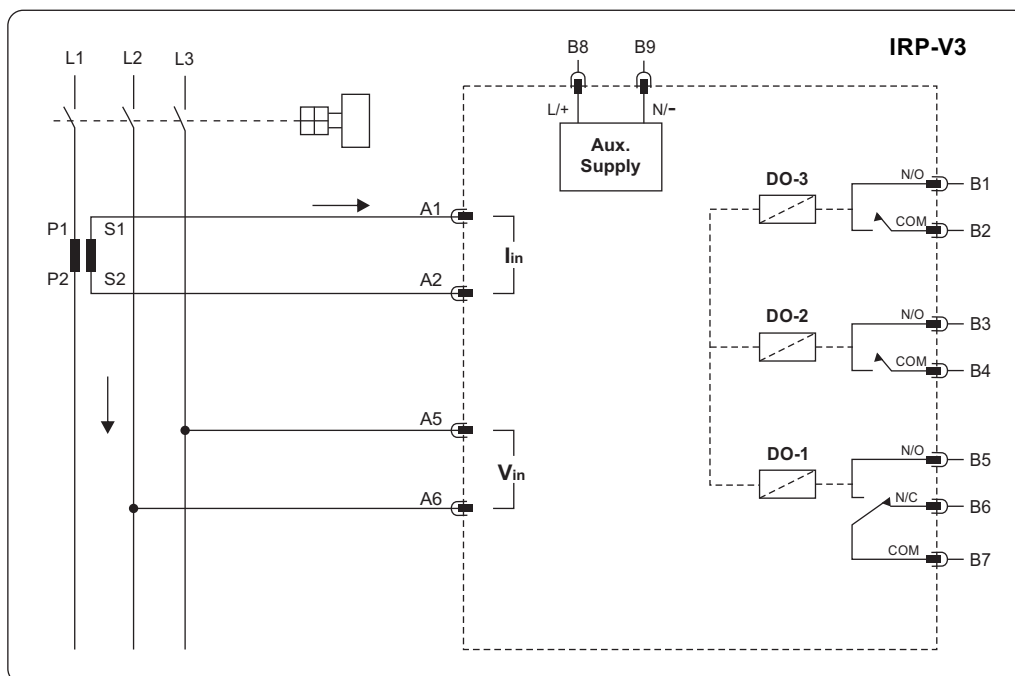

Connection Line to Line Voltage in 3 Phase, 3 Wire System

NOTE: The proper connection of k(s1) and l(s2) is to be observed

- Voltage measurement inputs L2 and L3 are to be connected
- The current measurement must be done here from phase L1

NOTE : Please use external PT at A5-A6 connection for Higher Voltage Application i.e. MV

### 13.0 Terminal Arrangement

There are two terminal blocks A & B block A is for voltage & current measuring input connection, while block B is for Auxiliary Supply & Trip contact connection as per below table :-

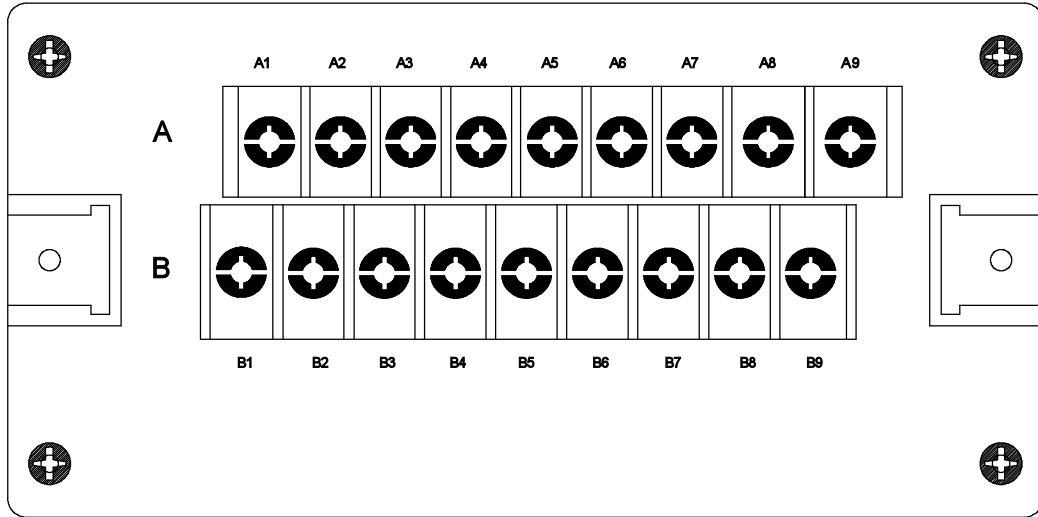

### 14.0 Terminal Description

TERMINAL	DESCRIPTION
<b>A</b>	
A1	Measuring Current Input (S1)
A2	Measuring Current Input (S2)
A5	Measuring Voltage Input - L1
A6	Measuring Voltage Input - N
	OR L3 L2
<b>B</b>	
B1	DO-3 N/O
B2	DO-3 COM
B3	DO-2 N/O
B4	DO-2 COM
B5	DO-1 N/O
B6	DO-1 N/C
B7	DO-1 COM
B8	Aux Supply (L / +)
B9	Aux Supply (N / -)

15.0 Dimension Details

(All the dimensions are in mm, Gen. Tol. :  $\pm 1.0$  mm)

Front View

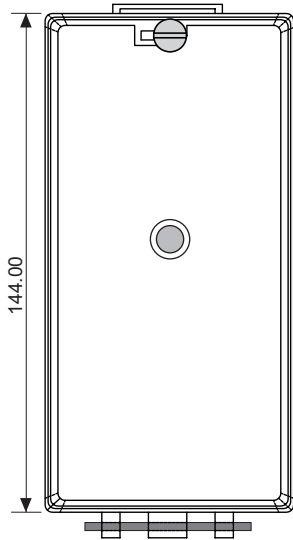

Side View

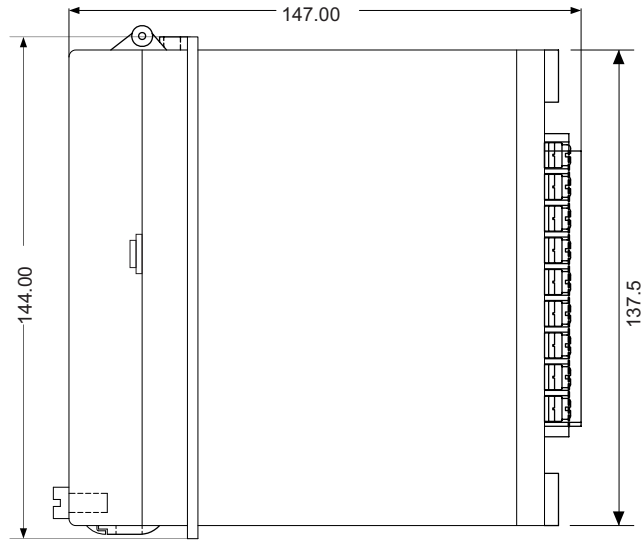

Top View

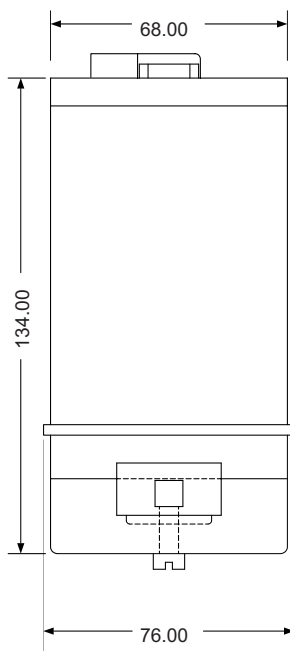

16.0 Panel Cut out Details

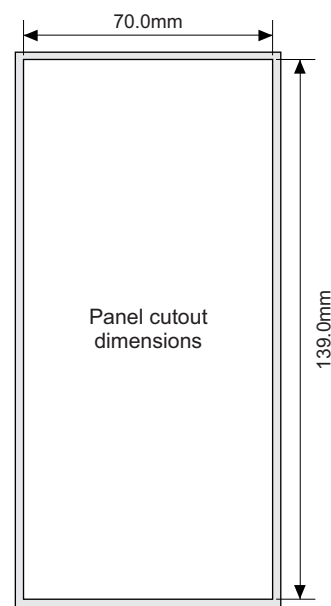

17.0 Ordering Information

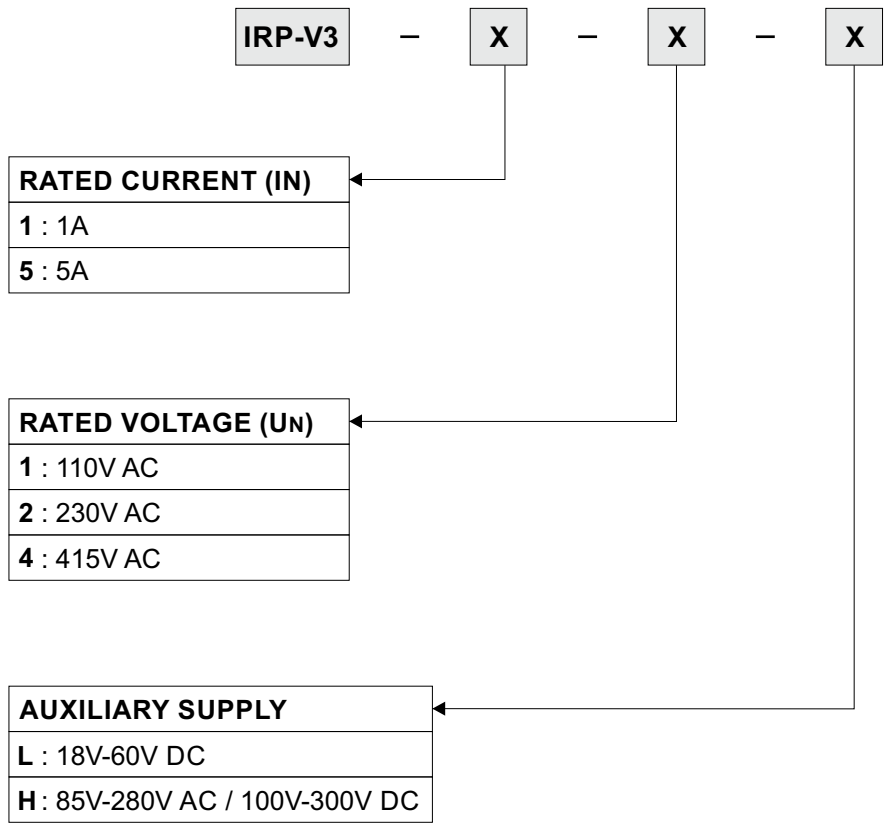

Example: **IRP-V3-5-1-H**

Model Code	Connection	Approx Rated Voltage to consider	Rated Current
IRP-V3-1-1	L-N / L-L	64V / 110V	1A
IRP-V3-5-1			5A
IRP-V3-1-2	L-N / L-L	133V / 230V	1A
IRP-V3-5-2			5A
IRP-V3-1-4	L-N / L-L	240V / 415V	1A
IRP-V3-5-4			5A

