

We touch your **electricity** everyday!

HI-TECH NEX SERIES



**DRAW-OUT
WITH SELF
CT SHORTING**

**FAULT EVENT
DISTURBANCE
RECORDER**

**DI/DO
PROGRAMMABLE
MATRIX**

**METERING
PROTECTION**

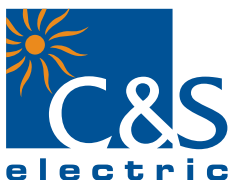

PMD Division

CONTENTS

S.No.	Description
1)	Introduction
2)	Features
3)	Application
4)	Hardware
5)	Protection Features
6)	Functional Diagram
7)	Protection Functions
8)	Fault Record
9)	Event Record
10)	Programmable Scheme Logic
11)	Disturbance Record
12)	Human Machine Interface
13)	Communication
	a) Rear Communication
	b) Front Communication
14a)	Setting Ranges : CSENEX-I 101/150 Model.....
14b)	Setting Ranges : CSENEX-I 350 Model.....
15)	Technical Data
16)	Specification Table of Hi-Tech Relays
17)	Recommended terminal lugs specification
18)	Standards
19a)	Connection Diagram for CSENEX-I 101/150.....
19b)	Connection Diagram for CSENEX-I 350.....
19c)	Connection Diagram for REF Application.....
19d)	Connection Diagram for Zero current differential protection of star point winding.....
19e)	Connection Diagram for Trip Circuit Supervision..
20)	Draw out process of the relay
21)	Dimensional Details (Vertical model)
22)	Mounting arrangement of the Relay
23)	Panel mounting of the Relay
24)	Ordering Information
25)	Revision History

Disclaimer

The information in this document is subject to change without any type of notice and should not be construed as a commitment by C&S. C&S assumes no responsibility for any errors that may appear in this document.

1) Introduction

CSENEXT Series offers a compact Multi-functional Over-current protection solution for Feeder, Generator, Motor & Transformer segment.

CSENEXT-I Family of protective relays are numeric relays that provides multi protection and monitoring with reliable and fast protection solution in a single unit.

CSENEXT-I series relays are an advanced feeder protection solution which has fast, sensitive and secure protection for feeder internal & external faults.

CSENEXT-I offers different model based features to cover the wide range of user.

2) Features

- 1A & 5A rated CT input (programmable)
- Draw out with self CT shorting
- DI/DO programmable matrix
- Protection blocking through DI
- Trip counter
- Two sets of setting groups *
- Fault recorder *
- Event recorder *
- Disturbance recording *
- Communication (Local & Remote)

3) Application

The CSENEXT-I relays have been designed for controlling, protecting and monitoring industrial, utility distribution networks and substations. They can also be used as part of a protection scheme for feeders, transformers and generators.

4) Hardware

- Micro controller based numeric design
- Measures true RMS with DFT filter
- 4 Current analog inputs
- Max. 6 Digital Inputs *
- Max. 6 Digital Outputs*
- (16x2)Alpha-numeric LCD
- RS-485 & USB communication
- 1A & 5A site selectable
- Fixed / Programmable * LEDs for Pickup & fault annunciation
- Push button on the front for HMI
- CT Terminal with Self shorting

5) Protection Features

- Three phase time over current
- Three phase instantaneous current
- Earth time over-current
- Earth instantaneous over-current
- Restricted Earth Fault *
- Derived Earth Fault *
- Cold load
- Harmonic blocking
- Thermal over load *
- Auto Re-closer *
- Current unbalance / Negative Phase Sequence *

6) Supervision Functions

- Circuit breaker failure
- Trip circuit supervision
- Broken conductor *

6) Functional Diagram

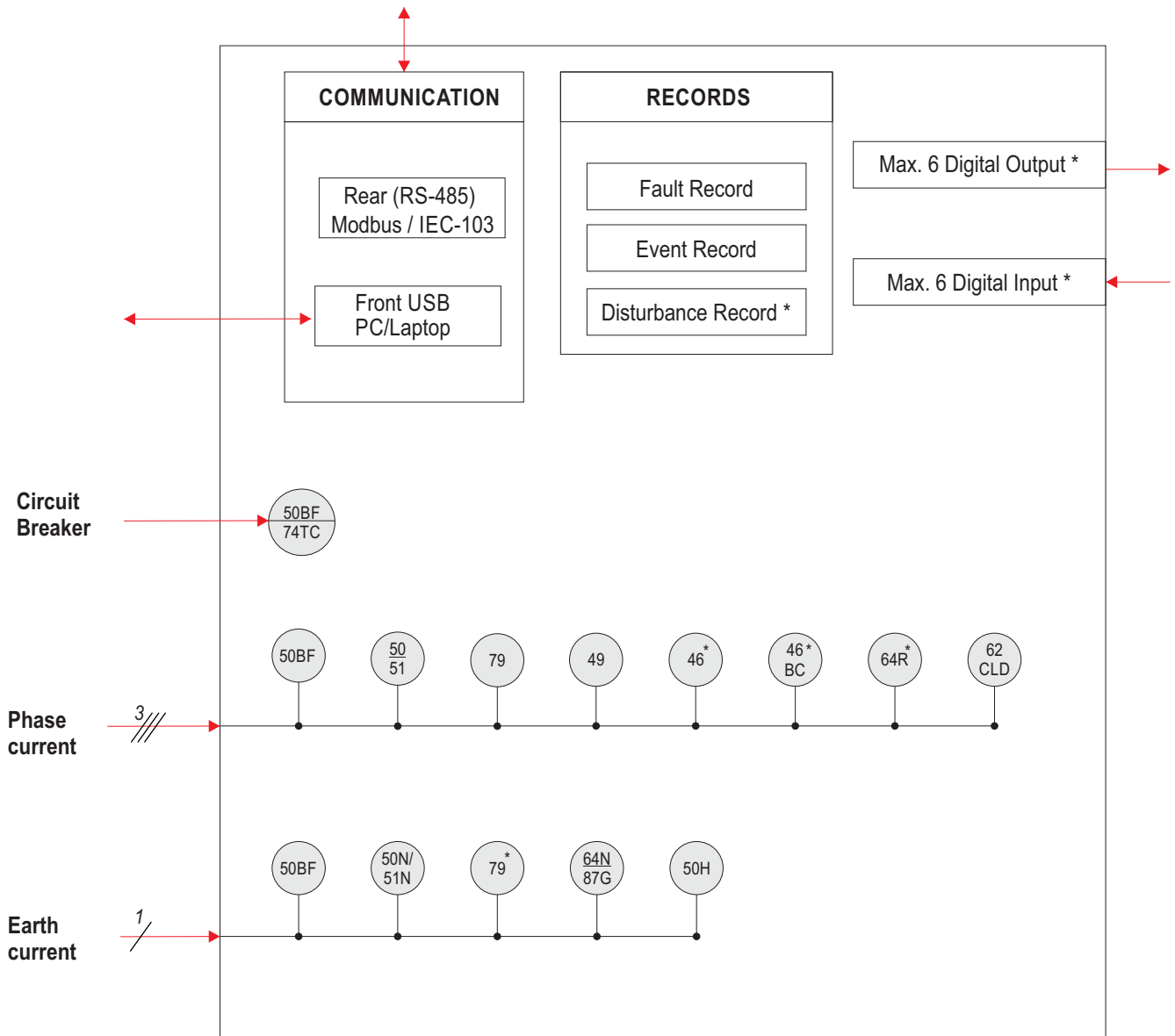

* Based on Ordering Information

(Figure 1)

7) Protection Functions

Three Phase Over-current Protection

The independent two stages are available for phase fault protection. For I> the user may independently select definite time delay or inverse time delay with different type of curves. The second Hi-Set stage can be configured with definite time only.

Earth Fault Protection

The independent two stages are available for earth fault protection. For first stage (Ie>) the user can select definite time delay or inverse time delay with different type of curves. The second Hi-Set stage can be configured with definite time only.

* Model dependent

Trip Circuit Supervision

This feature continuously supervises trip circuit of both pre closing and post closing conditions in circuit breaker. It detects tripping mechanism failure like circuit breakage contact degeneration in wires, contacts and coils.

Note: Trip counter is incremented on the basis of getting trip command from relay and not on the basis of external mechanism (circuit breaker) operation.

Harmonic Blocking

Harmonic block detects high inrush current inflows that occurs upon connection of transformers or rotating machines. The function will block the phase over-current and earth fault elements.

In CSENEX-I 101 & CSENEX-I 150 Harmonic Blocking is activated by default and in CSENEX-I 1350, it is configurable.

Circuit Breaker Failure Protection

The CB Failure Protection is based on supervision of phase and earth currents after tripping events. The test criterion is whether all phase currents have dropped to less than 5% of I_n within tCBFP. If one or more of the phase currents have not dropped to specified current within this time, CB failure is detected and the assigned output relay is activated.

Reset Delay

This parameter introduces a delay in opening of relay contacts, when the current goes below the drop out value for over current, short circuit, earth fault, earth high set etc. This parameter will not work when manual reset mode is selected.

Auto Re-closer *

As 80% of faults in overhead lines are transient, the use of the auto re-closer is very advantageous. Automatic auto-recloser allows a substation to operate unattended. The number of visits on site to manually re-close a circuit breaker after a fault, can then be substantially reduced. This feature gives an important advantage for substations supervised remotely.

Typically this auto re-close (AR) sequence of Instantaneous Trip(s) and Re-close Delays (Dead times) followed by Delayed Trip(s) provide the automatic optimum method of clearing all types of faults i.e. both Transient and Permanent, as quickly as possible and helps in improving the up time of the network in service.

DI Inputs:

AR Blocking - To block the auto re-closer through remote DI
CB Close DI - To get the circuit breaker status
CB Ready - To get the CB ready or to give the closing command

Configurable Outputs:

79 AR Close CB
79 Lockout

AR-Blocked

Unit changes immediately to "AR-blocked" status when an external AR Blocking DI is applied or internal EXIT is chosen for AR cycle in MMI. No Auto re-closing is possible in "AR-blocked" status.

Activating of AR:

Prior to every AR it is possible to select which kind of tripping ($I >$ or $I >>$, $I_e >$ etc.) will lead to automatic re-closing. This can be separately fixed for each protection.

Dead time (td):

Starts with the off signal of the circuit breaker. No closing command to the circuit breaker is given till expiry of

NOTE: Trip Test is available in HMI to check all LEDs and Digital Output (Relay)

* Model dependent

User programmable dead times are available for each protection trip operation.

The dead time is initiated when the trip output contact resets, the pickup is reset and the CB is open.

The CB close output relay is energized after the dead time has elapsed If CB ready input is present.

The dead time (dead time td1, dead time td2 dead time td3 dead time td4) starts when the feedback on 'CB CLOSE DI' is not available.

Reclaim Time (tr)

This is the time during which after switching on or after AR a subsequent re-closing is prevented. If the number of the set shots is reached, the relay is locked for this time after the last re-closing attempt. If CB Ready DI is not available relay will not generate closing command.

If the circuit breaker dose not trip again, the auto re-close cycle resets to original STATE-1 at the end of the reclaim time. If the protection operates during the reclaim time of the relay:

- either advances to the next AR cycle that is expected in next auto re-close state or
- if all the programmed re-closer attempts have been accomplished, it locks out.

The reclaim time is started with the automatic closing command.

Once a CB has re-closed and remained closed for a specified time period (the reclaim time), the AR sequence is reinitialized and a successful close output issued. A single common reclaim time is used (Reclaim Timer). when an auto re-close sequence does not result in a successful re-closure the relays goes to the lock out state.

Starting Condition for Auto Re-closer

- 1) AR should be enabled by manual setting.
- 2) AR blocked DI is not available
- 3) Respective protection AR cycle should not in exit condition.

Lock out State

Lockout state of the breaker means no further attempts to AR in these conditions

- 1) Lockout occurs when all auto re-closure attempts are over & protection operates during the final Reclaim Time.
- 2) If CBFP failure appeared in relay (if CBFP enable).
- 3) At the end of the each reclaim timer if the CB is in the open position (Close DI is not present).
- 4) If a Close pulse of AR relay is given and the CB fails to close through close DI input or expiry of Trip Contact Sense time.
- 5) If a open pulse given to CB and CB fails to open in between Trip Contact Sense time.

In any of these cases, Manual reset will be required to reinitiate the AR.

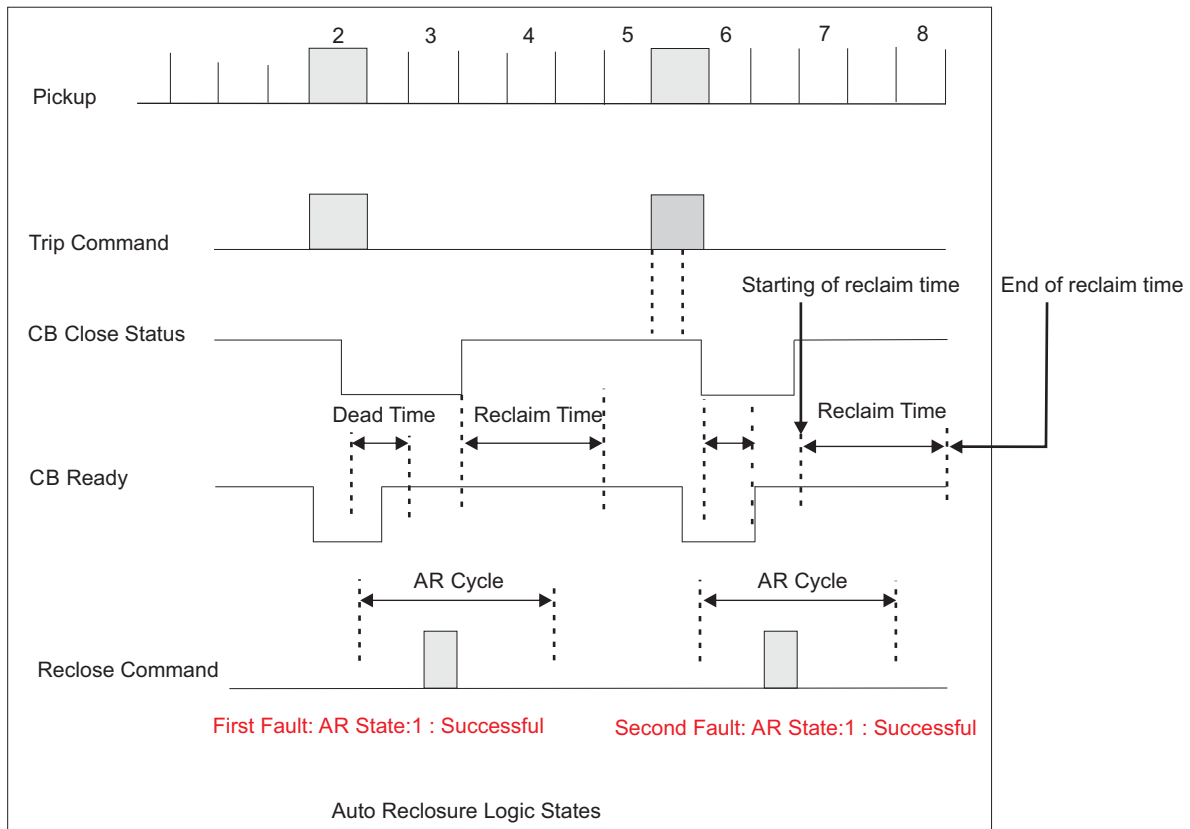

(Figure 2)

Thermal Over load Protection *

Thermal overload protection can be applied to prevent damages to the electrical plant equipment when operating at temperatures in excess of the designed maximum withstand. A prolonged over loading causes excessive heating, which may result in premature deterioration of the insulation or in extreme cases, insulation failure.

CSENEX-I relays incorporate a current based thermal replica, using load current to reproduce the heating and cooling of the equipment to be protected. The element thermal overload protection can be set with both alarm and trip stages.

The heating within any plant equipment, such as cables or transformers, is of resistive type ($I^2R \times t$), thus the quantity of heat generated is directly proportional to current squared (I^2). The thermal time characteristics used in the relay is based on current squared, integrated over time.

The CSENEX-I relays automatically use the highest phase current as input information for the thermal model.

The thermal time characteristic is given by following formula:-

* Model dependent

The formula for calculating the trip characteristics is as follows:

$$\text{Trip time (taus)} = \tau \cdot \ln \left[\frac{\left(\frac{I^2}{I_b^2} \right) - p^2}{\left(\frac{I^2}{I_b^2} \right) - k^2} \right] \quad \text{for } p^2 < \frac{I^2}{(I_b^2)} \quad np^2 \leq k^2$$

with τ = thermal time constant of the object to be protected.

I_b = Basic current

I_p = Initial load current

p = Initial load factor ($p=0$ means cold operating component)

k = constant

for thermal characteristics user has two choices

Thermal is based on highest measured RMS current

In CSENEX-I relay three modes are available for saving of thermal memory during power reset.

These modes are programmable.

M1 : On Power Reset thermal memory becomes 0.

M2 : On Power Reset thermal memory starts from the same value as at the time of Power Off.

M3 : On Power Reset thermal memory subtracts for the time it is in Off state & starts from the remaining value.

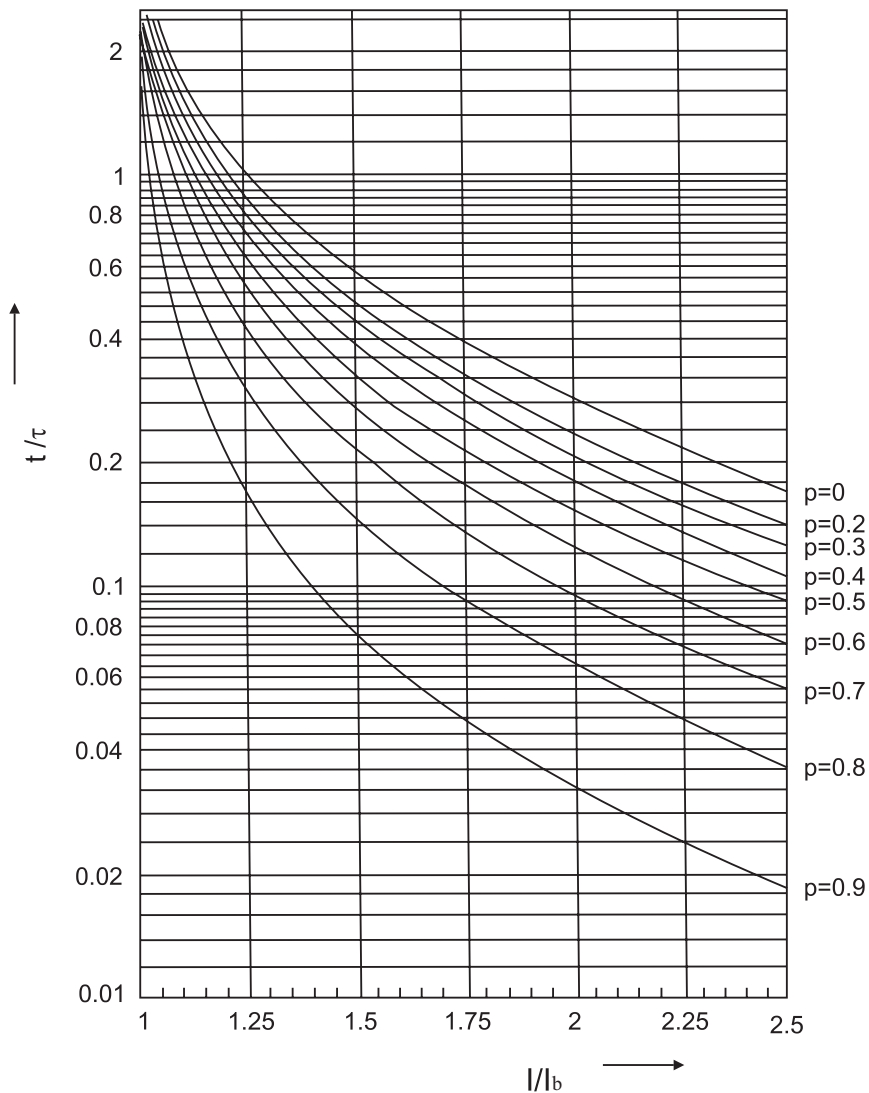

Cold Load Pickup

This function aims to avoid non-desired trips in the following situation: after being the line de-energized for a period of time and re-energized later, the load exceed the protection setting without the presence of a fault. This may be due to the fact that the off period of all the loads (furnaces, heaters, coolers etc.) is elapse and they are all connected at the same time, producing a strong inrush current in the line, but which can be supported within certain time. This phenomenon can occur not only at the moment of the breaker manual closing, after having remained open for a certain time, but also with the breaker permanently closed due to the operation of another upstream breaker.

What the function does, is detecting when those conditions are given and changing the tripping settings during a programmable time.

The function is activated when the current in the 3 phases is below 0.05A, then the programmed time starts to run to determine that the load is cold (this time can be 0, what means that any circuit breaker opening could lead to the cold load situation). Once that time has expired and the current has not exceed again 0.08A, the protection usual setting values are replaced by the cold load pickup ones (cold load group settings). When any of the phase current exceed 0.08A a counter with programmable time starts, during which the setting are the cold load pickup ones (cold load group settings). When expiring this time, the settings are again the usual ones. For settings Refer Cold Load Pickup Table in Setting Ranges.

Broken Conductor Protection *

Majority of faults on a power system are shunt faults and induce appreciable current increase so easily detectable by standard over current protection element.

Another type of unbalanced system condition is the series or open circuit fault. This fault can arise from broken conductors, mal operation of single phase switchgear or the operation of fuses.

Series faults will not induce an increase in phase current on the system and hence are not easily detectable. However on a lightly loaded line, the negative sequence current resulting from a series fault condition may be very close to or less than the full load steady state unbalance arising from CT errors, load unbalance etc. a negative sequence protection element therefore would not operate at low load levels.

CSENEX relays incorporate a protection element, which measures the ratio of negative to positive phase sequence current (I_2/I_1). This protection element will be affected to a lesser extent than the measurement of negative sequence current alone, since the ratio is approximately constant with variations in load current. Hence a more sensitive setting may be achieved.

Self-supervision function

The relays built-in self-supervision system continuously monitors the state of the relay hardware and the operation of the relay software. Any fault or malfunction detected will be used for alerting the operator. A permanent relay fault will block the protection functions of the relay to prevent incorrect relay operation. The relay supports a built-in test mode which enables user to test the relay HMI and binary outputs.

* Model dependent

Negative Phase Sequence Over current *

This function protects against current unbalances resulting from anomalies in the power System or unbalanced loads. Negative phase sequence over current element give greater sensitivity to resistive phase to phase faults, where phase overcurrent element may not operate.

If I_2 is Negative phase sequence current then

$$3 \cdot |I_2| = |I_a + a^2 \cdot I_b + a \cdot I_c| \text{ Where } a = 1 \angle 120^\circ$$

The Trip can be time delayed by a curve selectable by settings.

Refer following formula for the inverse characteristics of Negative Phase Sequence protection: -

Negative Phase Sequence Equation

$$t = \frac{K1}{(I_2/I_{2s})^2 - 1}$$

$K1$: TMS for Inverse characteristics of NPS

t : Expected Trip Time

I_2 : Measured negative sequence value

I_{2s} : Permissible NPS value

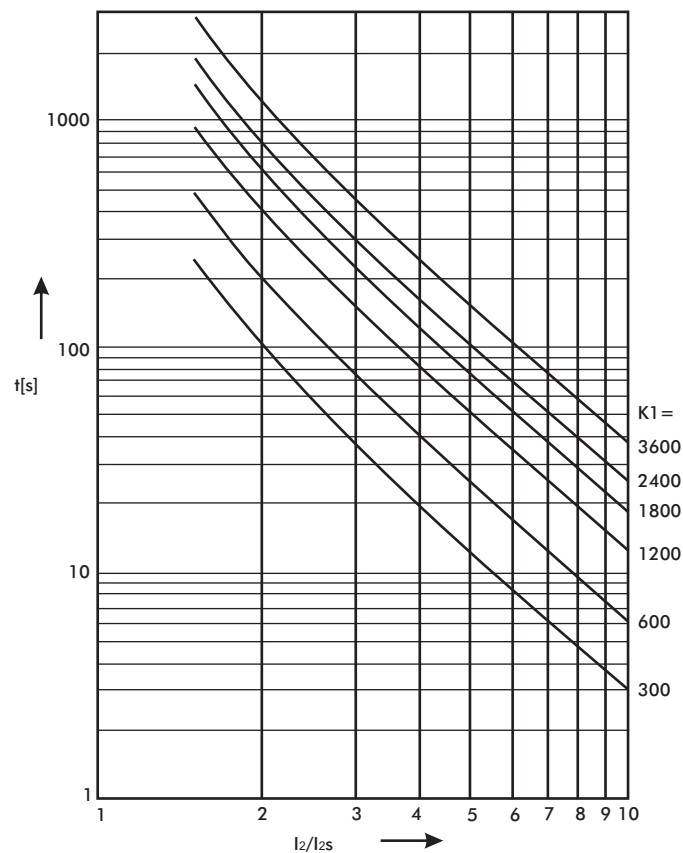

Negative Phase Sequence Inverse Time Characteristics

* Model dependent

Restricted Earth Protection *

The restricted earth fault relay is high impedance differential scheme which balances zero sequence current flowing in the transformer neutral against zero sequence current flowing in the transformer phase windings. Any unbalance for in-zone fault will result in an increasing voltage on the CT and thus will activate the Ref protection.

If REF is enabled then Restricted Earth Fault current is measured directly from CT terminals and Earth fault is derived from three phase currents (3I₀).

This scheme is very sensitive and can then protect against low levels of fault current in resistance grounded systems where the earthing impedance and the fault voltage limit the fault current.

Relay serves as a supplement for the generator differential protection. It allows for example implementation of a zero current differential protection by integrating the star-point current. With the view to its higher resistance to disturbance from outside the protection area. It can be set much more sensitivity than the simple generator differential protection in order to prevent false tripping.

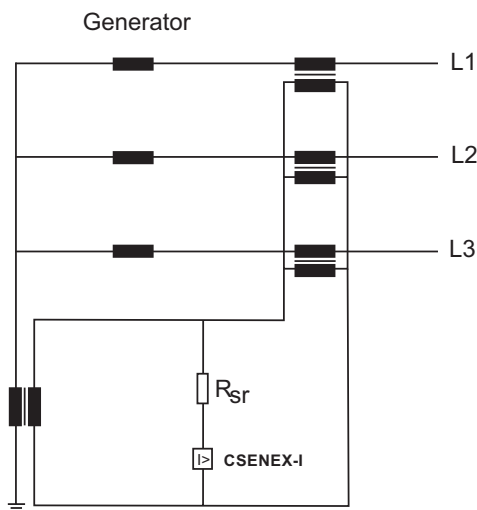

Zero current differential protection of the star point winding (restricted earth fault 64REF) of a generator

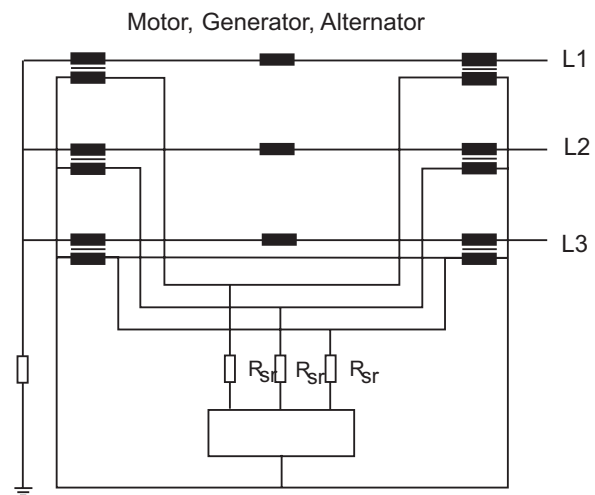

Under this wiring / application over current functions can be used as REF.

Highly stabilized differential current relay for alternator, generators and motors

Derived Earth Over current

There is a provision of derived / calculated Earth fault protection in the relay; where relay measures the zero sequence current from calculation of three phase vector summation.

$$I_{e_d} (3 I_0) = (I_{L1} + I_{L2} + I_{L3})$$

Derived calculated Earth fault protection starts from 10%.

The derived earth over current has two independent thresholds: $I_{e_d} >$ and $I_{e_d} >>$.

REF / Earth Fault Protection availability

REF Protection	DIRECT (Analog) measurement of Earth Current	DIRECT (Analog) measurement of REF Current	Calculated Derived Earth Fault (3 I ₀) from 3 Phase current
ENABLED	NOT AVAILABLE	AVAILABLE	AVAILABLE
DISABLED	AVAILABLE	NOT AVAILABLE	AVAILABLE

* Model dependent

8) Fault Record (based on ordering information of model)

CSENEX-I records last 20 faults in its non volatile memory with it's Date & time stamp. Each record has the following information:

Fault Format

[F] IL1 : 00.00A
 [F] IL2 : 00.00A
 [F] IL3 : 00.00A
 [F] Ie : 00.00A
 HR MIN : HH:MM
 SEC mSEC : Sec:mSec
 DATE : DD:MM:YY
 F-TYPE :

FAULT TYPE

Where

[F][ILx] Magnitude of phase current's.

[F]Ie Magnitude earth fault current's

F-Type Origin of fault (over current etc). (See Figure 3)

whenever the available memory space is exhausted the new fault automatically over writes the oldest fault. When the relay trips the description of fault in the feeder will appears on the LCD screen automatically and by pressing i key one can easily get all the detailed information of that fault.

The user can view the fault record either via front USB interface software or remotely via the RS-485 communication.

Sr No	FaultName	TimeStamp	IL1	IL2	IL3	IE	IREF	I2	Ie_d	ThermalMemory	Relay operation time[Sec]	Breaker Operation Time[Sec]	Load Resume Time[Sec]
1	OverCurrent Fault In L1 Phase	26/09/2023 17:20:37:570	0.30 A	0.00 A	0.00 A	0.00 A	0.00 A	0.10 A	0.30 A	0 %	0.104	2.161	Not Resumed
2	OverCurrent Fault In L1 Phase	26/09/2023 17:20:33:728	0.30 A	0.00 A	0.00 A	0.00 A	0.00 A	0.10 A	0.30 A	0 %	0.105	2.671	1
3	OverCurrent Fault In L1 Phase	26/09/2023 17:20:30:089	0.30 A	0.00 A	0.00 A	0.00 A	0.00 A	0.10 A	0.30 A	0 %	0.105	2.655	1
4	OverCurrent Fault In L1 Phase	26/09/2023 17:20:28:508	0.30 A	0.00 A	0.00 A	0.00 A	0.00 A	0.10 A	0.30 A	0 %	0.104	0.773	1
5	OverCurrent Fault In L1 Phase	26/09/2023 17:20:26:567	0.30 A	0.00 A	0.00 A	0.00 A	0.00 A	0.10 A	0.30 A	0 %	0.104	1.026	1
6	OverCurrent Fault In L1 Phase	26/09/2023 17:20:24:511	0.30 A	0.00 A	0.00 A	0.00 A	0.00 A	0.10 A	0.30 A	0 %	0.104	0.972	1
7	OverCurrent Fault In L1 Phase	26/09/2023 17:20:21:688	0.30 A	0.00 A	0.00 A	0.00 A	0.00 A	0.10 A	0.30 A	0 %	0.104	1.296	1
8	OverCurrent Fault In L1 Phase	26/09/2023 17:20:19:572	0.29 A	0.00 A	0.00 A	0.00 A	0.00 A	0.10 A	0.30 A	0 %	0.104	1.023	1
9	Circuit Breaker Failure Protection Fault	26/09/2023 17:20:17:360	0.29 A	0.00 A	0.00 A	0.00 A	0.00 A	0.10 A	0.30 A	0 %	0.025	3.128	1
10	OverCurrent Fault In L1 Phase	26/09/2023 17:20:15:569	0.30 A	0.00 A	0.00 A	0.00 A	0.00 A	0.10 A	0.30 A	0 %	0.105	Not Operated	Not Resumed
11	Short Circuit Stage1 Fault In L1 Phase	26/09/2023 17:18:35:314	2.00 A	0.00 A	0.00 A	0.00 A	0.00 A	0.67 A	2.04 A	0 %	0.105	Not Operated	Not Resumed
12	OverCurrent Fault In L1 Phase	26/09/2023 17:18:35:314	2.00 A	0.00 A	0.00 A	0.00 A	0.00 A	0.67 A	2.04 A	0 %	0.105	1.234	99
13	Short Circuit Stage1 Fault In L1 Phase	26/09/2023 17:18:31:496	2.00 A	0.00 A	0.00 A	0.00 A	0.00 A	0.67 A	2.01 A	0 %	0.104	2.786	1
14	OverCurrent Fault In L1 Phase	26/09/2023 17:18:31:490	2.00 A	0.00 A	0.00 A	0.00 A	0.00 A	0.67 A	2.01 A	0 %	0.104	Not Operated	Not Resumed
15	Short Circuit Stage1 Fault In L1 Phase	26/09/2023 17:18:23:014	2.00 A	0.00 A	0.00 A	0.00 A	0.00 A	0.67 A	2.04 A	0 %	0.105	Not Operated	Not Resumed
16	OverCurrent Fault In L1 Phase	26/09/2023 17:18:23:014	2.00 A	0.00 A	0.00 A	0.00 A	0.00 A	0.67 A	2.04 A	0 %	0.105	1.239	7
17	Short Circuit Stage1 Fault In L1 Phase	26/09/2023 17:18:21:256	2.00 A	0.00 A	0.00 A	0.00 A	0.00 A	0.67 A	2.04 A	0 %	0.104	0.729	Not Resumed
18	OverCurrent Fault In L1 Phase	26/09/2023 17:18:21:251	2.00 A	0.00 A	0.00 A	0.00 A	0.00 A	0.67 A	2.04 A	0 %	0.104	Not Operated	Not Resumed
19	Short Circuit Stage1 Fault In L1 Phase	26/09/2023 17:18:18:957	2.00 A	0.00 A	0.00 A	0.00 A	0.00 A	0.67 A	2.01 A	0 %	0.104	1.198	1
20	OverCurrent Fault In L1 Phase	26/09/2023 17:18:18:952	2.00 A	0.00 A	0.00 A	0.00 A	0.00 A	0.67 A	2.01 A	0 %	0.104	Not Operated	Not Resumed

(Figure 3) (Fault Data Recording on PC software)

9) Event Record (based on ordering information of model)

The unit stores in non volatile memory the last 100 events records. When the available memory space is exhausted, the new event automatically overwrites the oldest event which can be retrieved from a PC, with the following format:

EVENT : EVENT NUMBER (CSE Nex-I 350 model)
 EVENT-TYPE : EVENT NUMBER (CSE Nex-I 101 & 150 model)
 HR MIN : HH:MM
 SEC mSEC : SEC:mSEC
 DATE : DD/MM/YY

- Date and time of the event
- Descriptive text of the event

The user can view event records via the front USB interface software (See Figure 4)

* Description of event number available in event list or in front end software, Pickup & Trip events are recorded.

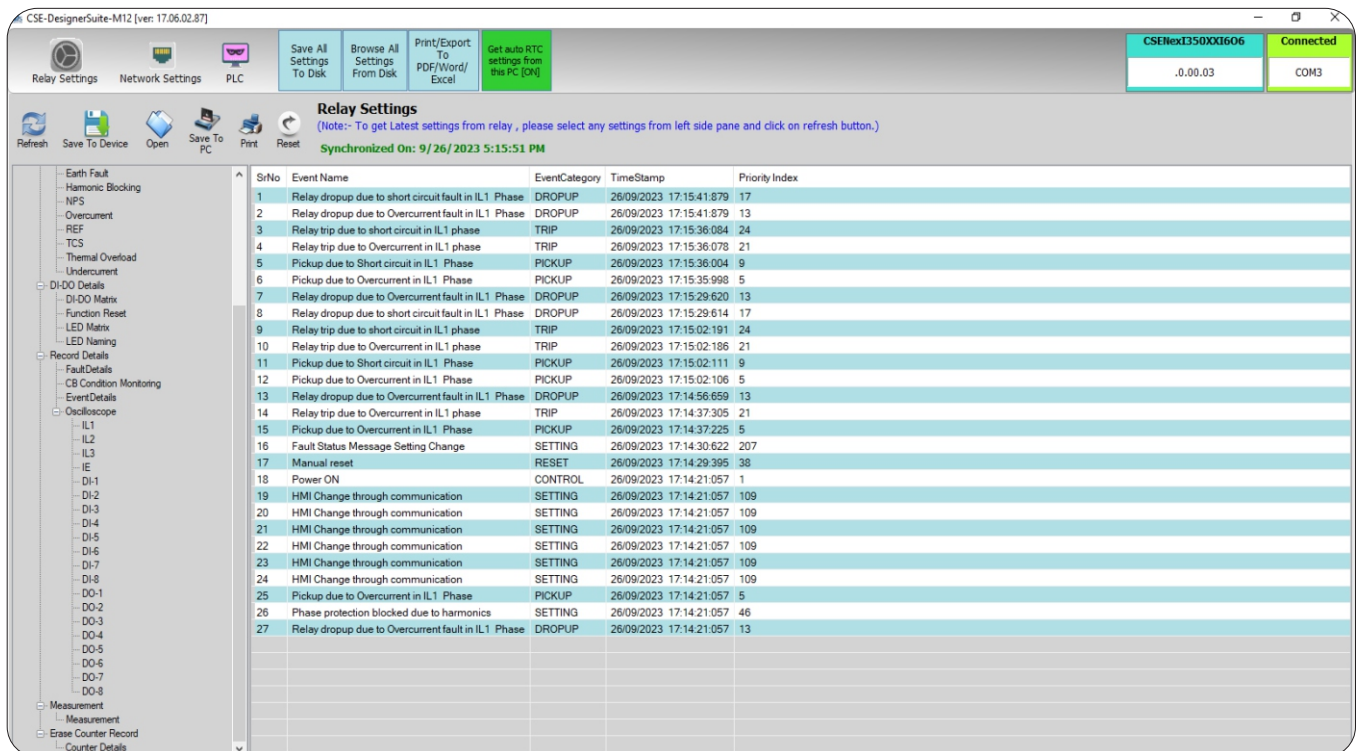

(Figure 4) (Event Data Recording on PC Software)

Output Contacts

No. of digital outputs : 06 Nos. (configurable)
 Type of outputs : Relay
 Programmable (DO Assignment): Yes
 Relay reset type : Programmable (Auto/Manual)

Input Contacts

No of digital inputs : 06 Nos. (configurable)
 Programmable (DI Assignment) : Yes

10) Programmable Scheme Logic (based on ordering information of model)

Programmable scheme logic is configured using the front end interface PLC Editor. This interface uses Boolean equations. Flexible logic allows user to create logic diagram to be assigned digital output.

The designed logic is event driven to ensure that protection is not delayed.

The following figure describes the use of protection schemes using the over current pickup & under voltage pickup from downstream relays to block operation of upstream relays using a digital output.

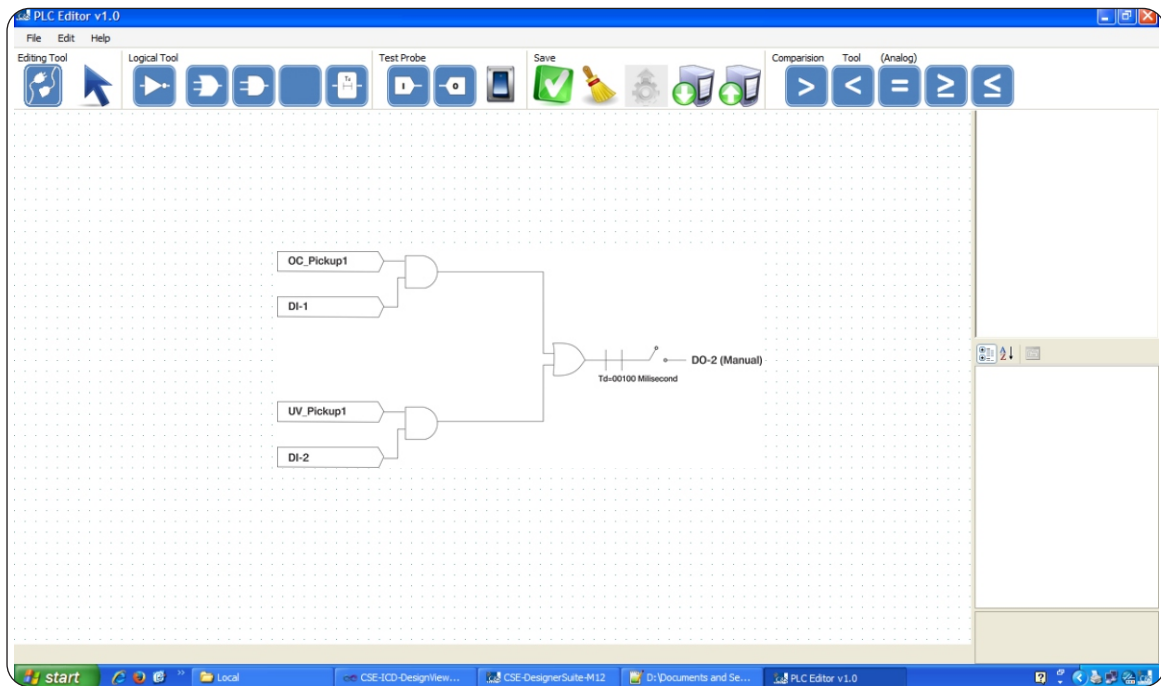

(Figure 5)

11) Disturbance Record (based on ordering information of model)

The relay has an oscillograph data recorder with the following characteristics:

- ◆ Oscilloscopic recording can trigger on Pickup or on trip or via DI i.e. change from pre-fault to post-fault stage. It is programmable.
- ◆ Each record comprises the samples from 4 analog signals and the status of 6 digital inputs and 6 digital outputs. There will be 30 samples per cycle.
- ◆ Relay saves maximum 1200 cycles, and the number of cycles per record is programmable (for example: if 40 cycles are selected, then there will be maximum 30 records of 40 cycles each).
- ◆ The pre-fault and post-fault cycles are programmable of oscilloscope (disturbance) record setting).
- ◆ Records are in the non volatile memory.
- ◆ The records are transferred to PC using USB interface. The data is graphically displayed & can be taken on printer.
- ◆ Record 1 is always latest record. 2nd record is older than 1st..... and so on.
- ◆ Disturbance record in comtrade format as per IEC60255-24.

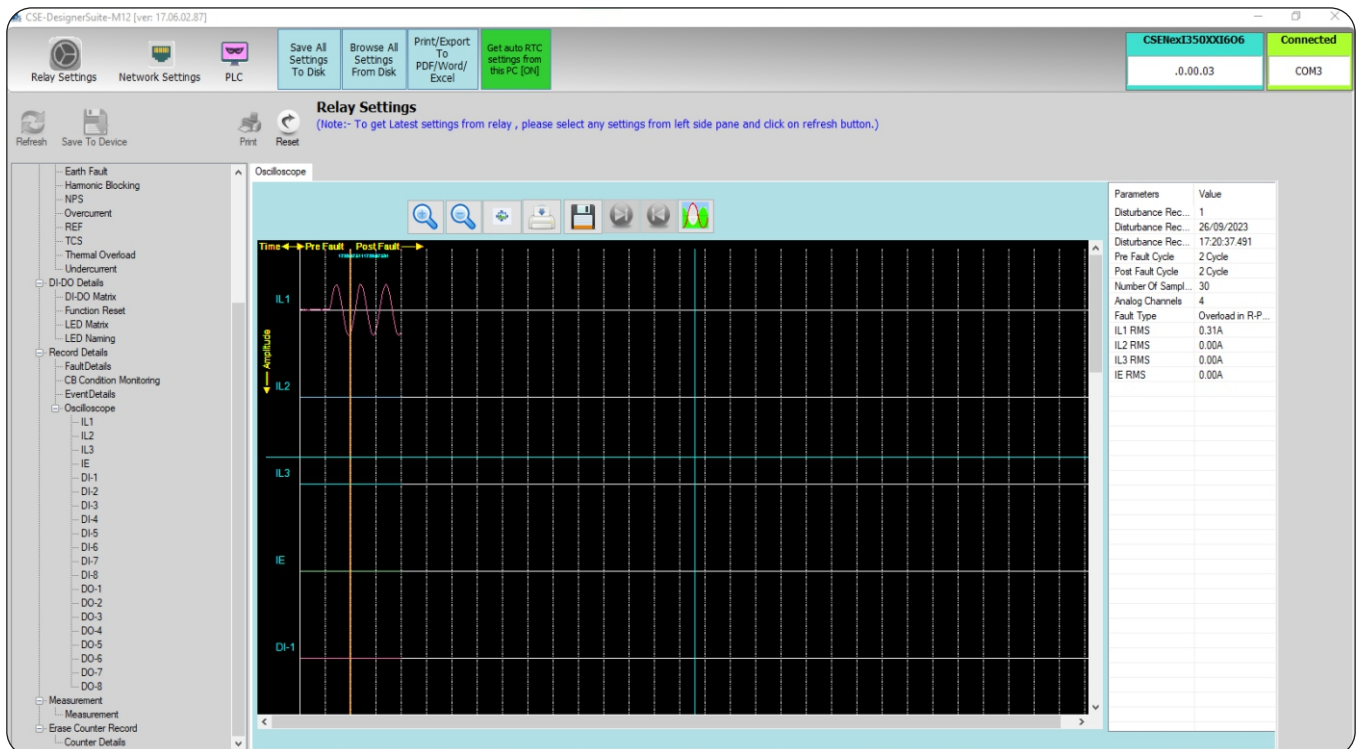

(Figure 6) (Disturbance Recording on PC software)

12) Human Machine Interface







It comprises of bright LCD display

- Four push switches for setting values of normal tripping characteristics and other operations for local access (model dependent).
- One RESET push switch.
- LEDs for pickup or tripping on fault and event in any phase (model dependent).



Model name, S.No. Insertion sticker
(based on model)

(Figure 7)

Keys	Manual Key
	is used as intelligent key to see the details of last fault and Relay status.
	is used to reach directly to the HOME screen.
	is used to set the status.
	is used to reset the fault status.
	is used to scroll in upward direction.
	is used to scroll in downward direction.

13) Communication (Local and Remote)

The unit has:

- 1 Front USB port for direct connection to a PC
- 1 Rear RS-485 communication port

a) Rear Communication

The protocol for the rear port is MODBUS-RTU.

b) Front Communication

The entire setting, Fault & Event are available on 'A' type USB (female) interface with CSE LIVELINK with saving & printing option. This unit also has Front-end Live Link simulation support for testing of relay even without any three phase injection source.

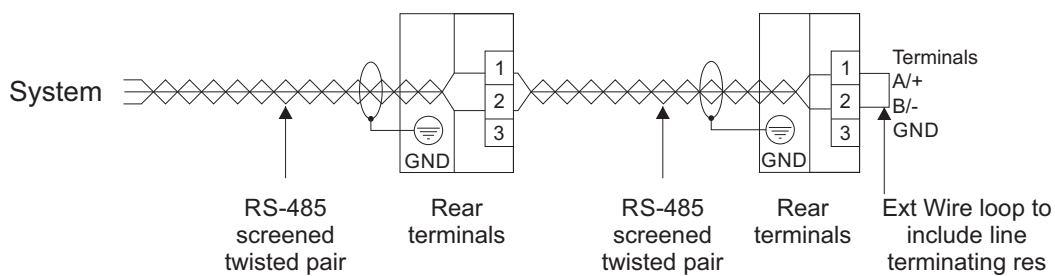

Communication to multiple devices from control system using RS-485

14a) Setting Ranges : CSENEX-I 101/150 model

Active Group Setting (Availability as per Model selection)

S.No.	Parameters	Display	Setting Range		Step Size	Default Setting
			Min	Max		
1	Active Group	ACTIVE	GROUP1	GROUP2	-	GROUP1

Common Setting

S.No.	Parameter	Display	Setting Range		Step Size	Default Setting
			Min.	Max.		
1	Rated Phase Current	Ip	1.00A	5.00A	-----	5.00A
2	Rated Earth Current	In	1.00A	5.00A	-----	1.00A
3	Phase CT Ratio	Ph CTR	0001	9999	1	1
4	Earth CT Ratio	E CTR	0001	9999	1	1
5	Fault Popup	F[Stat]	Enable	Disable	-----	Enable
6	Reset Delay	RstDI	0sec	20sec	0.1sec	0sec
7	Event Write	EvntSel	Disable	Enable	-----	Disable

Phase Over Current Protection

S.No	Parameter	Display	Setting Range		Step Size	Default Setting
			Min	Max		
1	Phase over-current low set pickup setting -1	I>	0.05xIp	4.00xIp	0.01xIp	Disable
2	Phase characteristics	PCURVE	DEFT/EINV/VINV//LINV/NINV1.3/NINV3.0/NINV0.6			DEFT
3	Phase over-current definite timing-1	t>	000.10s	150.00s	000.01s	000.10s
4	Phase over-current inverse timing-1	ti>	00.01	15.00	00.01	00.10
5	Phase over-current hi-set pickup setting-2	I>>	00.05xIp	30.00xIp	00.01xIp	Disable
6	Phase over-current hi-set definite timing-2	t>>	00.00s	20.00s	00.01s	00.10s

Very Inverse
$$t = \frac{13.5}{(I/IS) - 1} \quad ti [s]$$

Extremely Inverse
$$t = \frac{80}{(I/IS)^2 - 1} \quad ti [s]$$

Long time Inverse
$$t = \frac{120}{(I/IS) - 1} \quad ti [s]$$

Normal Inverse 3.0/1.3/0.6
$$t = \frac{0.14/0.061/0.028}{(I/IS)^{0.02} - 1} \quad ti [s]$$

Where t = Tripping time ti = Time multiplier
 I = Fault current IS = Setting value of current

For Current Range 0.2 to 20xIn:

Trip timing Accuracy : VINV / NINV 3.0 / 1.3 / DEFT : $\pm 5\%$ OR ± 40 mSec (whichever is higher)
 EINV / NINV 0.6 / LINV : $\pm 7.5\%$ OR ± 40 mSec (whichever is higher)

For Current Range 0.05 to 0.2xIn:

Trip timing Accuracy : VINV / NINV 3.0 / 1.3 / DEFT : $\pm 20\%$ OR ± 40 mSec (whichever is higher)
 EINV / NINV 0.6 / LINV : $\pm 20\%$ OR ± 40 mSec (whichever is higher)

Earth Setting (50N/51N) for CSENEX-I 101/150

(Availability as per model selection)

S.No	Parameter	Display	Setting Range		Step Size	Default Setting
			Min	Max		
1	Earth over-current low set pickup setting	le>	0.05xIn	2.5xIn	0.01xIn	Disable
2	Earth Characteristics	ECURVE	DEFT/EINV/VINV/LINV/NINV1.3/NINV3.0/NINV0.6			DEFT
3	Earth over-current low set definite timing	te>	000.03s	150.00sc	000.01s	000.10s
4	Earth over-current low set inverse timing	tie>	0.01	15.00	00.01	00.10
5	Earth over-current hi-set pickup setting	le>>	0.05xIn	20.00xIn	00.01xIn	Disable
6	Earth over-current hi-set definite timing	te>>	00.00s	20.00s	00.01s	00.10s

Trip Circuit Supervision Protection

S.No.	Parameter	Display	Setting Range		Step Size	Default Setting
			Min.	Max.		
1	TCS	td	0.03s	2.00s	0.01s	Disable

Circuit Breaker Failure Protection

S.No.	Parameter	Display	Setting Range		Step Size	Default Setting
			Min.	Max.		
1	CBFP	tCBFP	0.03 Sec	2.00S	0.01S	Disable

Broken Conductor Protection (Available in 150 Model)

Parameters	Display	Setting Range		Step Size	Default Setting
		Min	Max		
NPS to PPS Ratio	I2/I1 Ratio	0.10	0.50	0.01	Disable
Definite Time for broken conductor fault	td(BC)	0.05sec	20.00sec	0.01sec	0.10sec

Current Unbalance / Negative Phase Sequence (Available in 150 Model)

S.No.	Parameter	Display	Setting Range		Step Size	Default Setting
			Min.	Max.		
1	Enable NPS	Enable	NO	YES	-----	YES
2	NPS characteristics	CHAR	DEFT	INVERSE	-----	DEFT
3	Pick up current	I2	0.10xlp	1.00xlp	0.01xlp	Disable
4	Time multiple	K1	05s	600s	01s	0.5s
5	Definite time	td	00.1s	600.0s	00.1s	00.2s

Negative Phase Sequence Equation

$$t = \frac{K1}{(I_2/I_{2s})^2 - 1}$$

Where I₂ is injected NPS current. Trip timing accuracy : $\pm 7.5\%$ OR $\pm 40\text{mSec}$ (whichever is higher)

Cold Load Protection

S. No	Parameter	Display	Setting Range		Step Size	Default Setting
			Min.	Max.		
1	Cold Load Pickup	CLPPKUP	Enable	Disable	-----	Disable
2	Cold Load Time	tcold	0.00s	100.00s	0.01s	0.01s
3	Cold Load pickup Time	tclp	0.00s	100.00s	0.01s	0.01s
3	Phase characteristics	PCURVE	DEFT/EINV/VINV/LINV/NINV1.3/NINV3.0/NINV0.6			DEFT
4	Earth Characteristics	E-CURVE	DEFT/EINV/VINV//LINV/NINV1.3/NINV3.0/NINV0.6			DEFT
5	Ph. over-current low set pickup setting:Stage-1	I>	0.05xlp	4.00xlp	0.01xlp	Disable
	Ph. over-current definite timing:Stage-1	t>	0.10s	150.00s	00.01s	000.10s
	Ph. over-current inverse timing:Stage-1	ti>	0.01	15.00	0.01	00.10
6	Ph. over-current hi-set pickup setting:Stage-2	I>>	0.05xlp	30.00xlp	0.01xlp	Disable
	Ph. over-current hi-set definite timing:Stage-2	t>>	0.00s	20.00s	00.01s	00.10s
7	Earth over-current low set pickup setting:Stage-1	Ie>	0.05xln	2.50xln	0.01xln	Disable
	Earth over-current low set definite timing:Stage-1	te>	000.03s	150.00s	00.01s	000.10s
	Earth over-current low set inverse timing:Stage-1	tie>	00.01	15.00	0.01	00.10
8	Earth over-current hi-set pickup setting:Stage-2	Ie>>	0.05xln	20.00xln	0.01xln	Disable
	Earth over-current hi-set definite timing:Stage-2	te>>	00.00s	20.00s	00.01s	00.10s

Erase Record (* Availability as per Model selection)

Parameter	Display	Setting Range		Default Setting
		Min.	Max.	
Trip Count Record	Trip_Cntr	NO	YES	NO
Thermal Reset *	ThrmLRset	NO	YES	NO
Event Erase Record	EventsErase	NO	YES	NO
Fault Erase Record	FaultsErase	NO	YES	NO
Osc. Record Erase *	OscRcrdEras	NO	YES	NO

Date & Time Setting

Parameters	Display	Setting Range		Step Size	Default Setting
		Min	Max		
Hour	HOUR	0	23	1	---
Minute	MIN	0	59	1	---
Second	SEC	0	59	1	---
Date	DATE	1	31	1	---
Month	MONTH	Jan	Dec	1	---
Year	YEAR(2000 Y)	00	99	1	---

Front (USB) Communication

Protocol	CSE proprietary protocol: available with front software
Baud rate	19200 bps
Cable required for interface	USB cable type (A to A)

Rear (RS-485) Communication

Protocol	MODBUS RTU, IEC-60870-5-103
Baud rate selection (programmable)	9600 / 19200 / 38400 bps
Parity selection (programmable)	Even / Odd / None
Stop bit	1 Bit
Data bit	8 Bit data
Slave Address (programmable)	(1 to 247)
Cable required for interface	Two wire twisted shielded cable

Auxiliary Supply (Availability as per Model selection)

Auxiliary Voltage Range	For W Model	18V-150V DC
	For H Model	80V-280V AC / 90V-300V DC
	For U Model	40V-280V AC / 18V-300V DC
Power Consumption		Quiescent approx. 3W
		Operating approx. <7W
Rated Supply for Digital Input	For W Model	18V-150V DC (Active)
		<10V DC (Inactive)
	For H Model	40V-280V AC (Active)
		40V-300V DC (Active)
		<25V AC/DC (Inactive)
	For U Model	40V-280V AC
		18V-300V DC
<10V AC/DC (Inactive)		

15) Technical Data

Trip Contact Rating

Contact Rating	
Contact relay	Dry contact Ag Ni
Make current	Max. 30A & carry for 3S
Carry capacity	8A continuous : Trip contact (DO-1 & DO-5)
	5A continuous : Alarm contact (DO-2, DO-3, DO-4, DO-6)
Rated voltage	250V AC/ 30V DC
DC Current carrying capacity	8A@30VDC / 0.3A@110VDC/ 0.2A@220VDC
Breaking Characteristics	
Breaking capacity AC	1500VA resistive
	1500VA inductive (PF=0.5)
Breaking capacity DC	220V AC, 5A (cos phi <=0.6)
	135V DC, 0.3A (L/R=30ms)
	250V DC, 50W resistive or
	25W inductive (L/R=40ms)
Operation time	<10ms
Durability	
Loaded contact	10,000 operation minimum
Unloaded contact	30,000 operation minimum

Over-voltage category : II, Insulation voltage : 300V, Pollution Degree : 2, IP-54 from Front

Measuring Input

Rated Data	Rated current I _p : 1A or 5A Rated frequency F _n : 50 Hz
Drop out to Pickup Ratio	>96%
Power consumption in current circuit	At I _p =1A 0.2 VA
	At I _p =5A 0.4 VA
Reset time	30mSec
Thermal withstand capability in current circuit	Dynamic current withstand
	(half wave): 250 x I _p
	for 1 Sec : 100 x I _p
	for 10 Sec : 30 x I _p
	continuously : 4 x I _p

* Model dependent

14b) Setting Ranges : CSENEX-I 350 Model

Active Group Setting

S.No.	Parameters	Display	Setting Range		Step Size	Default Setting
			Min	Max		
1	Active Group	ACTIVE	GROUP1	GROUP2	-	GROUP1

Common Setting

S.No.	Parameter	Display	Setting Range		Step Size	Default Setting
			Min.	Max.		
1	Rated Phase Current	Ip	1.00A	5.00A	-----	1.00A
2	Rated Earth Current	In	1.00A	5.00A	-----	1.00A
3	Phase CT Ratio	Ph CTR	0001	9999	1	0001
4	Earth CT Ratio	E CTR	0001	9999	1	0001
5	Frequency Ratio	FREQ [Fn]	50Hz	60Hz	10Hz	50Hz
6	Fault Popup	[F]Stat	Enable	Disable	-----	Enable
7	Event Write	EVNTfun	Disable	Enable	-----	Disable
8	Out of Service	Outof Ser	Enable	Disable	-----	Disable
9	PLC Function	PLCfun	Enable	Disable	-----	Disable

Phase Over Current Protection

S.No	Parameter	Display	Setting Range		Step Size	Default Setting
			Min	Max		
1	Phase characteristics	PCurve	DEFT/EINV/VINV//LINV/NINV1.3/NINV3.0/NINV0.6			DEFT
2	Phase over-current low set pickup setting -1	I>	0.05xIp	5.00xIp	0.01xIp	0.80xIp
3	Phase over-current definite timing-1	t>	000.10s	150.00s	000.01s	000.10s
4	Phase over-current inverse timing-1	tj>	00.010	15.000	00.005	00.050
5	Phase over-current hi-set pickup setting-2	I>>	00.50xIp	40.00xIp	00.01xIp	01.20xIp
6	Phase over-current hi-set definite timing-2	t>>	00.00s	20.00s	00.01s	00.10s

Under current protection

S.No	Parameter	Display	Setting Range		Step Size	Default Setting
			Min	Max		
1.	Under Current Pickup	I<	0.20xIp	1.00xIp	0.01xIp	Disable
2.	Under Current Timing	t<	001.00s	260.00s	0.01s	2.00s
3.	Under Current Threshold	ThrsSet	0.50xIp	1.00xIp	0.05xIp	0.50xIp

Very Inverse $t = \frac{13.5}{(I/IS) - 1} t_i [s]$

Extremely Inverse $t = \frac{80}{(I/IS)^2 - 1} t_i [s]$

Long time Inverse $t = \frac{120}{(I/IS) - 1} t_i [s]$

Normal Inverse 3.0/1.3/0.6 $t = \frac{0.14/0.061/0.028}{(I/IS)^{0.02} - 1} t_i [s]$

Where t = Tripping time t_i = Time multiplier
 I = Fault current IS = Setting value of current

For Current Range 0.2 to 20xIn:
 Trip timing Accuracy : VINV / NINV 3.0 / 1.3 / DEFT : +5% OR +40mSec (whichever is higher)
 EINV / NINV 0.6 / LINV : ±7.5% OR ±40mSec (whichever is higher)

For Current Range 0.05 to 0.2xIn:
 Trip timing Accuracy : VINV / NINV 3.0 / 1.3 / DEFT : +20% OR +40mSec (whichever is higher)
 EINV / NINV 0.6 / LINV : ±20% OR ±40mSec (whichever is higher)

Earth Setting

S. No	Parameter	Display	Setting Range		Step Size	Default Setting
			Min	Max		
1	Earth over-current low set pickup setting	le>	0.05xIn	4.00xIn	0.01xIn	0.50xIn
2	Earth Characteristics	E-CURVE	DEFT/EINV/VINV/LINV/NINV1.3/NINV3.0/NINV0.6			DEFT
3	Earth over-current low set definite timing	te>	0.03s	150.00s	000.01s	000.10s
4	Earth over-current low set inverse timing	tie>	0.01	1.500	00.001	0.050
5	Earth over-current hi-set pickup setting	le>>	0.05xIn	20.00xIn	00.01xIn	0.80xIn
6	Earth over-current hi-set definite timing	te>>	00.0s	20.00s	00.01s	00.10s
7.	Derived Earth current function	le_d>Fn	ENABLE / DISABLE		----	Disable
8.	Derived Earth current pickup	le_d>	00.10xlp	15.00Xlp	00.01	01.00xlp
9.	Derived Earth current definite time	te_d>	00.02s	100.00	00.01	00.10s
10.	Derived Earth current Hi-set function	le_d>>Fn	ENABLE / DISABLE		----	Disable
11.	Derived Earth current Hi-set pickup	le_d>>	00.10xlp	15.00xlp	00.01	01.00xlp
12.	Derived Earth Hi-set definite time	te_d>>	00.02s	100.00	00.01	00.10s

Trip Circuit Supervision Protection

S.No.	Parameter	Display	Setting Range		Step Size	Default Setting
			Min.	Max.		
1	TCS	td	0.03s	2.00s	0.01s	Disable

Circuit Breaker Failure Protection

S.No.	Parameter	Display	Setting Range		Step Size	Default Setting
			Min.	Max.		
1	CBFP	tCBFP	0.03 Sec	2.00s	0.01	Disable

Broken Conductor Protection

Parameters	Display	Setting Range		Step Size	Default Setting
		Min	Max		
NPS to PPS Ratio	I ₂ /I ₁	0.05	1.00	0.01	Disable
Definite Time for broken conductor fault	td(BC)	0.0s	600.00s	0.02s	0.20s

Current Unbalance / Negative Phase Sequence

S.No.	Parameter	Display	Setting Range		Step Size	Default Setting
			Min.	Max.		
1	Pick up current	I ₂	0.10xlp	1.00xlp	0.01xlp	Disable
2	NPS characteristics	CHAR	DEFT	INVERSE	----	DEFT
3	Time multiple	K ₁	05	600	1.0	05
4	Definite time	td	0.10s	600s	0.10s	0.20s

Negative Phase Sequence Equation

$$t = \frac{K_1}{(I_2/I_{2s})^2 - 1}$$

Where I₂ is injected NPS current. Trip timing accuracy : ±7.5% OR ±40mSec (whichever is higher)

Cold Load Protection

S. No	Parameter	Display	Setting Range		Step Size	Default Setting
			Min.	Max.		
1	Cold Load Pickup	CLP PKUP	Enable	Disable	-----	Disable
2	Cold Load Time	tcold	0000.0s	1000.0s	000.1s	0001.0s
3	Cold Load Pickup Time	tclP	0.0001s	1000.00s	000.1s	0001.0s
4	Phase characteristics	PCURVE	DEFT/EINV/VINV/LINV/NINV1.3/NINV3.0/NINV0.6			DEFT
5	Earth Characteristics	E-CURVE	DEFT/EINV/VINV/LINV/NINV1.3/NINV3.0/NINV0.6			DEFT
6	Ph. over-current low set pickup setting - Stage-1	I>	0.20xlp	5.00xlp	0.01xlp	Disable
	Ph. over-current definite timing - Stage-1	t>	0.10s	150.00s	000.01s	000.10s
	Ph. over-current inverse timing - Stage-1	ti>	0.010	1.500	0.005	0.05
7	Ph. over-current hi-set pickup setting - Stage-2	I>>	00.50xlp	40.00xlp	00.01xlp	Disable
	Ph. over-current hi-set definite timing - Stage-2	t>>	00.02s	20.00s	00.01s	00.10s
8	Earth over-current low set pickup setting-Stage-1	Ie>	0.05xln	4.00xln	0.01xln	Disable
	Earth over-current low set definite timing-Stage-1	te>	000.03s	150.00s	000.01s	000.10s
	Earth over-current low set inverse timing-Stage-1	tie>	0.010	1.500	0.005	0.050
9	Earth over-current hi-set pickup setting-Stage-2	Ie>>	0.05xln	20.00xln	0.01xln	Disable
	Earth over-current hi-set definite timing-Stage-2	te>>	0.02s	20.00s	00.01s	00.10s

Harmonic Blocking Protection

S.No	Parameter	Display	Setting Range		Step Size	Default Setting
			Min	Max		
1.	Phase 2nd harmonic block	P2ndH	10% If	50% If	1% If	10% If
2.	Phase 3rd harmonic block	P3rdH	10% If	50% If	1% If	10% If
3.	Earth 2nd harmonic block	E2ndH	10% If	50% If	1% If	10% If
4.	Earth 3rd harmonic block	E3rdH	10% If	50% If	1% If	10% If
5.	Phase blocking time	tPHASE	00.00s	20.00s	0.1s	00.00s
6.	Earth block time	tEARTH	00.00s	20.00s	0.1s	00.00s

Thermal Over load

S.No.	Parameters	Display	Setting Range		Step Size	Default Setting
			Min	Max		
1	Thermal memory	MemMod	M1	M3	1.0	M1
2	Permissible basic current	Ib	0.20xI _p	4.00xI _p	0.02xI _p	Disable
3	Constant	k	0.50	2.00	0.01	1.00
4	Heating time constant	Th	000.5min	180.0min	000.1min	000.5min
5	Cooling constant	Tc	1.00xTh	8.00xTh	0.01xTh	1.00xTh
6	Thermal alarm	Thrm_A	20%	99%	1%	20%
7	Thermal reset	TH_Rst	20%	99%	1%	50%

Auto Re-closer Mode

S.No.	Parameter	Display	Setting Range		Step Size	Default Setting
			Min.	Max.		
1	Enable Auto-recloser	FUN ENB	YES	NO	-----	NO
2	Dead time 1	D1	000.20s	300.00s	0.01s	000.20s
3	Dead time 2	D2	000.20s	300.00s	0.01s	000.20s
4	Dead time 3	D3	000.20s	300.00s	0.01s	000.20s
5	Dead time 4	D4	000.20s	300.00s	0.01s	000.20s
6	Reclaim time	tR	000.20s	300.00s	0.01s	000.20s
7	Phase over-current low set max AR cycle	Cyc I>	2 / 3 / 4 / Disable		1	2
8	Phase over-current hi-set max AR cycle	Cyc I>>	2 / 3 / 4 / Disable		1	2
9	Earth over-current low set max AR cycle	Cyc Ie>	2 / 3 / 4 / Disable		1	2
10	Earth over-current hi-set max AR cycle	Cyc Ie>>	2 / 3 / 4 / Disable		1	2
11	Trip sense time	t_TST	0.05s	2.00s	0.01s	0.10s

Breaker Capacity / CB conductor setting

S.No.	Parameter	Display	Setting Range		Step Size	Default Setting
			Min.	Max.		
1	Pick up current	I _{2t} _Fun	Enable / Disable			----Disable
2	Alarm	Alrm	0001.0KA2S	3000.0KA2S	0.1KA2S	0009.9KA2S
3	Trip	Trip	0001.0KA2S	3000.0KA2S	0.1KA2S	0099.9KA2S

Restricted Earth Fault Protection

Parameters	Display	Setting Range		Step Size	Default Setting
		Min	Max		
REF pickup current	Iref>	0.05xIn	30.00xIn	00.01xIn	Disable
REFtrip time	tref>	00.00s	10.00s	00.01s	1.00s

DO Assignment

Over current alarm	al>	Auto re-close	AR CLS
Over current trip	tl>	Auto re-close lockout	ARlock
Short circuit stage alarm	al>>	Trip circuit supervision	TCS
Short circuit stage trip	tl>>	Circuit breaker failure protection	CBFP
Earth protection alarm	ale>	Self supervision	SLF SU
Earth protection trip	tle>	Under current protection alarm	al<
Earth high protection alarm	ale>>	Under current protection trip	tl<
Earth high protection trip	tle>>	Broken conductor protection alarm	aBC>
Negative phase seq. protection alarm	al2>	Broken conductor protection trip	tBC>
Negative phase seq. protection trip	tl2>	Remote trip-1	RmtTp1
Restricted Earth Fault alarm	aREF	Remote trip-2	RmtTp2
Restricted Earth Fault trip	tREF	Remote trip-3	RmtTp3
Derived Earth Fault Stage-1 Alarm	aDE1	Remote trip-4	RmtTp4
Derived Earth Fault Stage-1 Trip	tDE1	Remote trip-5	RmtTp5
Derived Earth Fault Stage-2 Alarm	aDE2	Remote trip-6	RmtTp6
Derived Earth Fault Stage-2 Trip	tDE2	I2t Alarm	I2t_AI
Thermal alarm	TH Alm	I2t Trip Time	I2t_Tr
Thermal relay	TH trp	DO Block	DOBlk

DI Assignment

Circuit breaker close	CB Cls	Short circuit stage1 block	I>> BK
Circuit breaker open	CB Opn	Earth block	E> BLK
CB Ready	CB Rdy	Earth high block	E>> BK
Remote trip-1	RmtTp1	Auto re-close block	AR BLK
Remote trip-2	RmtTp2	Thermal block	Th BLK
Remote trip-3	RmtTp3	Cold load pickup block	CldBLK
Remote trip-4	RmtTp4	Negative phase sequence block	I2> BLK
Remote trip-5	RmtTp5	Restricted earth fault block	REF>BK
Remote trip-6	RmtTp6	Under current block	I<BLK
Group toggle	GRP tg	Broken conductor block	BC BLK
Remote reset	RmtRst	Derived Earth Fault Stage-1 Block	DRV1BK
Oscillator trigger	OSC Tg	Derived Earth Fault Stage-2 Block	DRV2BK
Over current block	I> BLK		

LED Assignment

Over current alarm	al>
Over current trip	tl>
Short circuit stage alarm	al>>
Short circuit stage trip	tl>>
Earth protection alarm	ale>
Earth protection trip	tle>
Earth high protection alarm	aE>>
Earth high protection trip	tE>>
Negative phase sequence protection alarm	al2>
Negative phase sequence protection trip	tl2>
Restricted Earth Fault alarm	aRE>
Restricted Earth Fault trip	tRE>
Derived Earth Fault Stage-1 Alarm	aDE1>
Derived Earth Fault Stage-1 Trip	tDE1>
Derived Earth Fault Stage-2 Alarm	aDE2>
Derived Earth Fault Stage-2 Trip	tDE2>
Thermal alarm	THal
Thermal relay	THtp
Auto re-close	ARCL
Auto re-close lockout	ARlk

Trip circuit supervision	TCS
Circuit breaker failure protection	CBFP
Self supervision	SLFS
Under current protection alarm	al<
Under current protection trip	tl<
Broken conductor protection alarm	aBC>
Broken conductor protection trip	tBC>
Remote trip-1	RmtTp1
Remote trip-2	RmtTp2
Remote trip-3	RmtTp3
Remote trip-4	RmtTp4
Remote trip-5	RmtTp5
Remote trip-6	RmtTp6
Negative phase sequence protection alarm	al2t
Negative phase sequence protection trip	tl2t
Common Block	CBlk
Common Pickup	CmPk
Common Trip	CmTr
Healthy LED	HLed
Out of Service	OOfs

Function Reset

Over current alarm	al>	Auto/Manual
Over current trip	tl>	Auto/Manual
Short circuit stage alarm	al>>	Auto/Manual
Short circuit stage trip	tl>>	Auto/Manual
Earth protection alarm	ale>	Auto/Manual
Earth protection trip	tle>	Auto/Manual
Earth high protection alarm	aE>>	Auto/Manual
Earth high protection trip	tE>>	Auto/Manual
Neg phase seq. protection alarm	al2>	Auto/Manual
Neg. phase seq. protection trip	tl2>	Auto/Manual
Restricted Earth Fault alarm	aREF>	Auto/Manual
Restricted Earth Fault trip	tREF>	Auto/Manual
Derived Earth Fault Stage-1 Alarm	ale_d>	Auto/Manual
Derived Earth Fault Stage-1 Trip	tle_d>	Auto/Manual
Derived Earth Fault Stage-2 Alarm	ale_d>>	Auto/Manual
Derived Earth Fault Stage-2 Trip	tle_d>>	Auto/Manual
Thermal alarm	Thm Alm	Auto/Manual

Thermal relay	Thm Trip	Auto/Manual
Auto re-close	AR Close	Auto/Manual
Trip circuit supervision	TCS	Auto/Manual
Under current protection alarm	al<	Auto/Manual
Under current protection trip	tl<	Auto/Manual
Broken conductor protection alarm	aBC>	Auto/Manual
Broken conductor protection trip	tBC>	Auto/Manual
Remote trip-1	RmtTp1	Auto/Manual
Remote trip-2	RmtTp2	Auto/Manual
Remote trip-3	RmtTp3	Auto/Manual
Remote trip-4	RmtTp4	Auto/Manual
Remote trip-5	RmtTp5	Auto/Manual
Remote trip-6	RmtTp6	Auto/Manual
Neg. phase seq. protection alarm	al2t>	Auto/Manual
Neg. phase seq. protection trip	tl2t>	Auto/Manual
DO Blocking	DOBlk	Auto/Manual

Disturbance Record

S. No.	Parameters	Display	Setting Range		Step Size	Default Setting
			Min	Max		
1	Oscilloscope record	RECORD	NO	YES	-	NO
2	Pre-fault cycle	PRE CYCLE	002C	298C	1C	002C
3	Post-fault cycle	POST CYCL	002C	298C	1C	002C
4	Triggering mode	TRIG MODE	PK-UP	PK-UP/TRIP/DI/Anyone	-	PK-UP

Erase Record

S.No.	Parameter	Display	Setting Range	Default Setting
1	Trip Count Record	All TrpCntr	NO / YES	NO
2	Thermal Reset	ThrmLRset	NO / YES	NO
3	Max Function Reset	Maxl[F]Rset	NO / YES	NO
4	Event Erase Record	EventsErase	NO / YES	NO
5	Fault Erase Record	FaultsErase	NO / YES	NO
6	Osc. Record Erase	OscRcrdEras	NO / YES	NO
7	Accumulated I ² t Reset	Accuml2tRst	NO / YES	NO

Date & Time Setting

Parameters	Display	Setting Range		Step Size	Default Setting
		Min	Max		
Hour	HOUR	0	23	1	---
Minute	MIN	0	59	1	---
Second	SEC	0	59	1	---
Date	DATE	1	31	1	---
Month	MONTH	Jan	Dec	1	---
Year	YEAR(2000 Y)	00	99	1	---

Front (USB) Communication

Protocol	CSE proprietary protocol: available with front software
Baud rate	19200 bps
Cable required for interface	USB cable type (A to A)

Rear Port (RS-485) Communication

Protocol	MODBUS RTU, IEC-60870-5-103
Baud rate selection (programmable)	9600 / 19200 / 38400 bps
Parity selection (programmable)	Even / Odd / None
Slave Address (programmable)	(1 to 247)
Stop bit	1 Bit
Data bit	8 Bit data
Cable required for interface	Two wire twisted shielded cable

Auxiliary Supply (Availability as per Model selection)

Auxiliary Voltage Range	For W Model	18-150V DC
	For H Model	80-280V AC / 90-300V DC
	For U Model	40-280V AC / 18-300V DC
Power Consumption		Quiescent approx. 3W
		Operating approx. <7W
Rated Supply for Digital Input	For W Model	18-150V DC (Active)
		<10V DC (Inactive)
	For H Model	40-280V AC (Active)
		40V-300V DC (Active)
For U Model	<25V AC/DC (Inactive)	
	40-280V AC (Active)	
	18-300V DC (Active)	
		<10V AC/DC (Inactive)

14) Technical Data

Trip Contact Rating

Contact Rating	
Contact relay	Dry contact Ag Ni
Make current	Max. 30A & carry for 3S
Carry capacity	16A continuous : Trip contact (DO-1) 250V AC / 24V DC
	8A continuous : Trip contact (DO-5)
	5A continuous : Alarm contact (DO-2, DO-3, DO-4, DO-6)
Rated voltage	250V AC/ 30V DC
DC Current carrying capacity	8A@30VDC / 0.3A@110VDC/ 0.2A@220VDC
Breaking Characteristics	
Breaking capacity AC	1500VA resistive
	1500VA inductive (PF=0.5)
	220V AC, 5A (cos ϕ <=0.6)
Breaking capacity DC	135V DC, 0.3A (L/R=30ms)
	250V DC, 50W resistive or
	25W inductive (L/R=40ms)
Operation time	<10ms
Durability	
Loaded contact	10,000 operation minimum
Unloaded contact	30,000 operation minimum

Over-voltage category : II, Insulation voltage : 300V, Pollution Degree : 2, IP-54 from Front

Measuring Input

Rated Data	Rated current I_p : 1A or 5A Rated frequency F_n : 50 Hz
Drop out to Pickup Ratio	>96%
Power consumption in current circuit	At $I_p=1A$ 0.2 VA
	At $I_p=5A$ 0.4 VA
Reset time	30mSec
Thermal withstand capability in current circuit	Dynamic current withstand
	(half wave): 250 x I_p
	for 1 Sec : 100 x I_p
	for 10 Sec : 30 x I_p continuously : 4 x I_p

16) Specification Table of HI-TECH (CSENEX-I) Relays

TABLE-A

Function	ANSI	Model 101	Model 150	Model 350
PROTECTIONS				
CT inputs	--	4	4	4
Setting Group	--	1	2	2
Over current	50/51	✓	✓	✓
Under current	37	-	-	✓
Earth Fault	50N/51N	✓	✓	✓
Restricted Earth Fault	64R	-	-	✓
Derived Earth Fault	50N	-	-	✓
CBFP	50BF	✓	✓	✓
Trip Circuit	74TC	✓	✓	✓
Harmonic Blocking	50H	available by default		configurable
Cold Load Pickup	62 CLD	✓	✓	✓
Thermal Over-load	49	-	-	✓
Current unbalance / NPS	46	-	✓	✓
Broken conductor	46BC	-	✓	✓
Auto Re-closer	79	-	-	✓
Programmable Scheme Logic	[PLC]	-	-	✓
RECORDS				
Fault Record	--	10	10	20
Event Record	--	50	50	100
Disturbance Record	--	-	-	✓
DISPLAY				
LCD Display (16x2)	--	✓	✓	✓
LED (Programmable/Fixed)	--	Fixed	Fixed	Programmable
COMMUNICATION				
Front Communication (USB)	--	✓	✓	✓
Rear Communication (RS-485)	--	○	○	○

○	: Ordering based
-	: Not available in this model
✓	: Available in this model

17) Recommended Terminal Lugs Specifications

Term Blocks	Type/Cable Specifications
Current Inputs	Ring Type lug / 2.5mm ² or 4 mm ² control cable
Auxiliary Supply	Pin Type lug / 1.5 mm ² / 2.5 mm ² control cable
Rear Comm. Port	Pin Type lug / 1.5 mm ² / 2.5 mm ² control cable
Front Comm. Port	USB, Type A - A
Binary Input	Pin Type lug / 1.5mm ² / 2.5mm ² control cable
Binary Output	Pin Type lug / 4.0mm ² control cable
Earth Connections	Ring Type / 2.5mm ² or 4 mm ² contact cable

18) Standards

Type Test			
F1	Functional Tests	Internal Design Specifications & IEC60255-151:2009	Performance in line with Specification & Standards Pickup / Drop down / Power consumption in Current / Voltage / Aux. Supply / Trip timing accuracy: OC / NPS / Thermal / Zero Sequence

Climatic Test			
C1	Temperature Dry Cold (Relay operational)	IEC 60068-2-1	-20 deg C, 96 hours
C2	Temperature Dry Cold Transportation & Storage	IEC 60068-2-1	-25 deg C, 96 hours
C3	Temperature Dry Heat (Relay operational)	IEC 60068-2-2	55 deg C, 96 hours
C4	Temperature Dry Heat Transportation & Storage	IEC 60068-2-2	70 deg C, 96 hours
C5	Damp Heat Test (Relay operational)	IEC 60068-2-30	95% @ +55 / +25 deg C, 6 cycle (12hr + 12hr each)

Enclosure			
C6	Enclosure	IEC 529	Front IP54 (Dust 5x + Water x4)

Mechanical Test

Relay Operational			
M1	Vibration response / Endurance test	IEC 60068-2-6	Class I Vibration response (Relay operational) 10Hz~150 Hz - peak displacement 0.035 mm below 58/60 Hz, 0.5 g above, 1 sweep cycle in each axis Vibration endurance (Relay de-energised) 10 Hz~150 Hz 1g, 20 sweep cycles in each axis
M2	Shock Response / Withstand Test	IEC 60255-2-27	Class I Shock response (Relay operational) 5g 11mS 3 pulse in each axis Shock withstand (Relay de-energised) 15g 11mS 3 pulses in each axis
M3	Bump Test	IEC 60255-21-1	Bump (Relay de-energised) 10g 16mS 1000 pulses in each axis
M4	Seismic Test	IEC 60255-21-3	Class I Method A single axis sine sweep 1 Hz~35 Hz~below 8/9 Hz 3.5 mm peak displacement horizontal axis, 1.5 mm vertical axis above 8/9 Hz 1g horizontal, 0.5 g vertical 1 sweep cycle in each axis

Electrical Test			
E1	Insulation Resistance >100MΩ	IEC 60255-27:2013	500V DC, 5 sec between all terminals & case earth, between terminals of independent circuits including contact circuits and across open contacts
E2	DC & AC Supply Voltage (Relay operational)	IEC 60255-26	Voltage range, upper & lower limit continuous withstand, ramp up & down over 1 minute
E3	Voltage Dips, Short Interruptions & Voltage variations immunity (Relay operational)	IEC 60255-26	3 Dips & 3 Interruptions at 10 sec intervals of duration between 10mS and 500mS at zero crossings & at other points on wave Variation: 100% to 40% over 2s, hold for 1s, return to 100% over 2s
E4	Ripple in DC supply (Relay operational)	IEC 60255-26	12% AC ripple
E5	Dielectric Test (Relay de-energised) No breakdown or flash over Test voltage 45~65 Hz sinusoidal or with DC voltage at 1.4x the stated AC values	IEC 60255-27:2013	2.0 KV @ 1min All circuit to Earth / Between IP & OP
E6	High Voltage Impulse (Relay de-energised)	IEC 60255-27:2013	5 kV peak 1.2/50uS, 0.5 J-3 positive, 3 negative between all terminals to case earth between independent circuits
E7	VT Input Thermal Withstand		1.5xVn, continuous
E8	CT Input Thermal Withstand		250xIn half wave 100xIn for 1 second 30xIn for 10 second 4xIn continuously
E9	Contact performance & endurance tests	IEC 60255-1:2009	

Electro-magnetic Compatibility			
R1	Electrical fast Transient/Burst (Relay operational)	IEC 60255-26 : 2013 IEC 61000-4-4	Class IV- ± 4.0 kV All Circuits. Pulse 5 / 50nsec / Duration 15msec / Period:300msec/Pulse Freq: 5KHz / 2KV at I/O
R2	HF Disturbance Test (Oscillatory Waves) 1 MHZ Burst (Relay operational)	IEC 60255-22-1 : 2007	Class III Longitudinal 2.5 kV peak, 2sec between independent circuits & case earth
R3	Electrostatic Discharge (Relay operational)	IEC 60255-26 : 2013 IEC 61000-4-2	Class III 8kV air discharge, 6KV contact No of Discharge : 10 both polarities at 1 sec intervals
R4	Conducted Disturbance RF fields (Relay operational)	CISPR-11 : 2015 IEC 60255-26 : 2013	0.15 to 80 MHZ (Level-3) Severity Level 10V RMS + sweeps 0.05-0.15 MHZ & 80-100 MHZ
R5	Radiated RF E-M field immunity test (Relay operational)	CISPR-22 : 2008 IEC 60255-26 : 2013	Class III Test method A + sweep 80-1000 MHZ or IEC 1000-4-3 80-1000 MHZ severity 10 V/m 80% modulated 1 kHz
R6	Surge Immunity capacitively coupled (Relay operational)	Latest: IEC 60255-26:2013	Short circuit combination wave generator 1.2 uS/50 uS open circuit repetition rate 1 per minute Power supply, CT & VT circuits – 4kV common mode 2 Ohm source 2kV differential mode 12 Ohm source
R7	Power Frequency Magnetic Field (Relay operational)	IEC 61000-4-8 : 2009	100 A/m for 1 minute in each of 3 axes
R8	Conducted & Radiated RF Interference Emission (Relay operational)	IEC 60255-26	CISPR-11 / Class A
R9	Power Frequency, conducted common mode	IEC 1000-4-16 IEC 60255-22-7	DC to 150 kHz Test Level 4 300V at 16 2/3 Hz and 50 Hz

19a) Connection Diagram for CSENEX-I 101 / 150

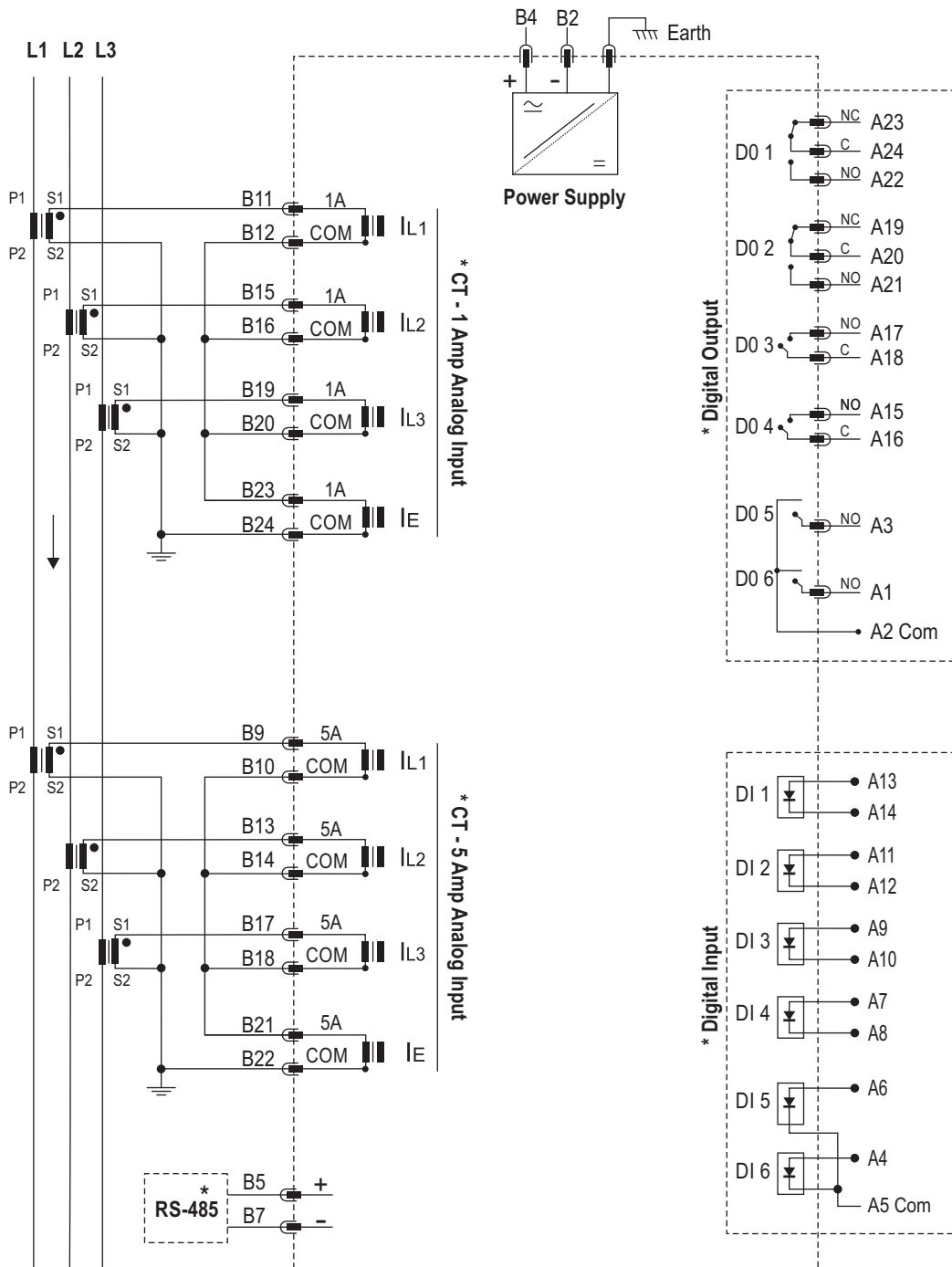

(Figure 8)

Digital Input availability as per Model Selection
DI 2 : DI 1 to DI 2 available
DI 4 : DI 1 to DI 4 available
DI 6 : DI 1 to DI 6 available

Digital Output availability as per Model Selection
DO 4 : DO 1 to DO 4 available
DO 6 : DO 1 to DO 6 available

* Availability of DI / DO / Analog Input / Com Terminal based on model selection

19b) Connection Diagram for CSENEX-I 350

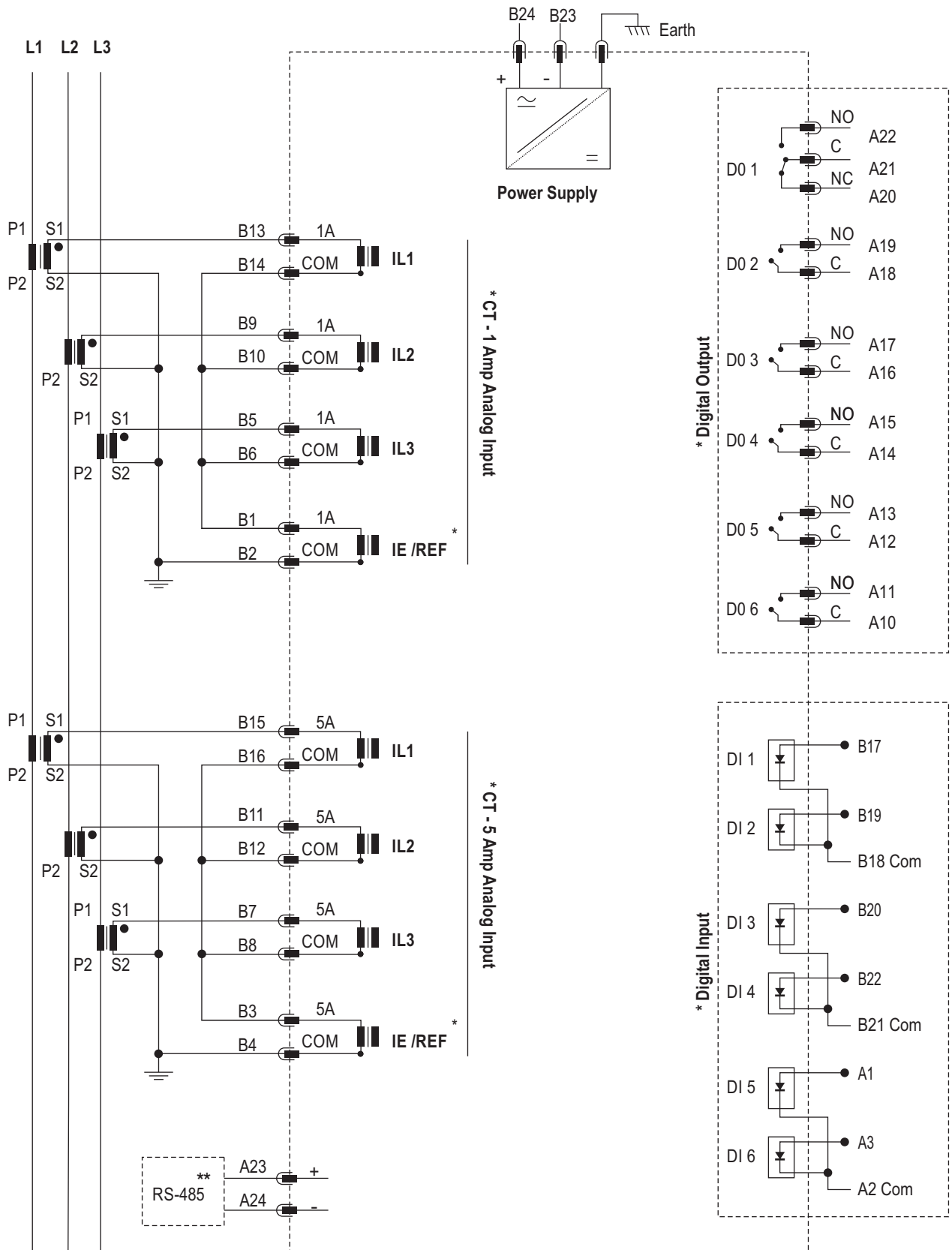

(Figure 9)

19c) Connection Diagram for REF Application for CSENEX-I 350

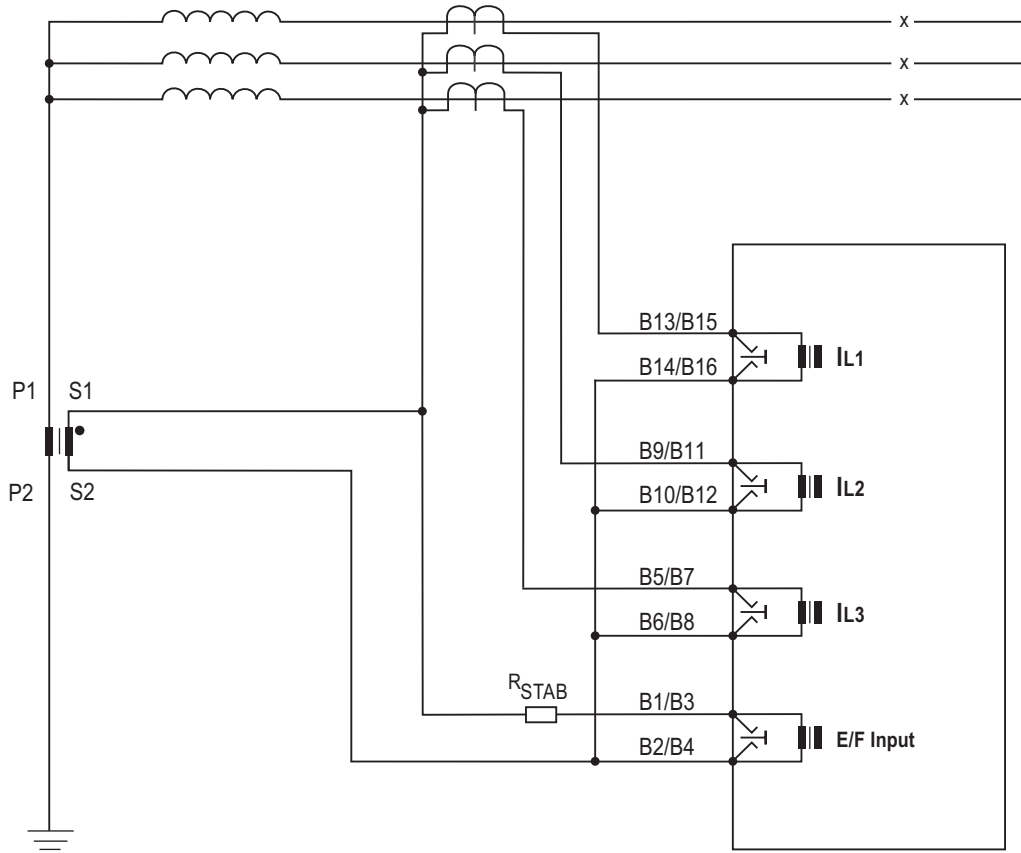

(Figure 10)

19d) CT Connection Diagram [3 OC + EF] for CSENEX-I 350

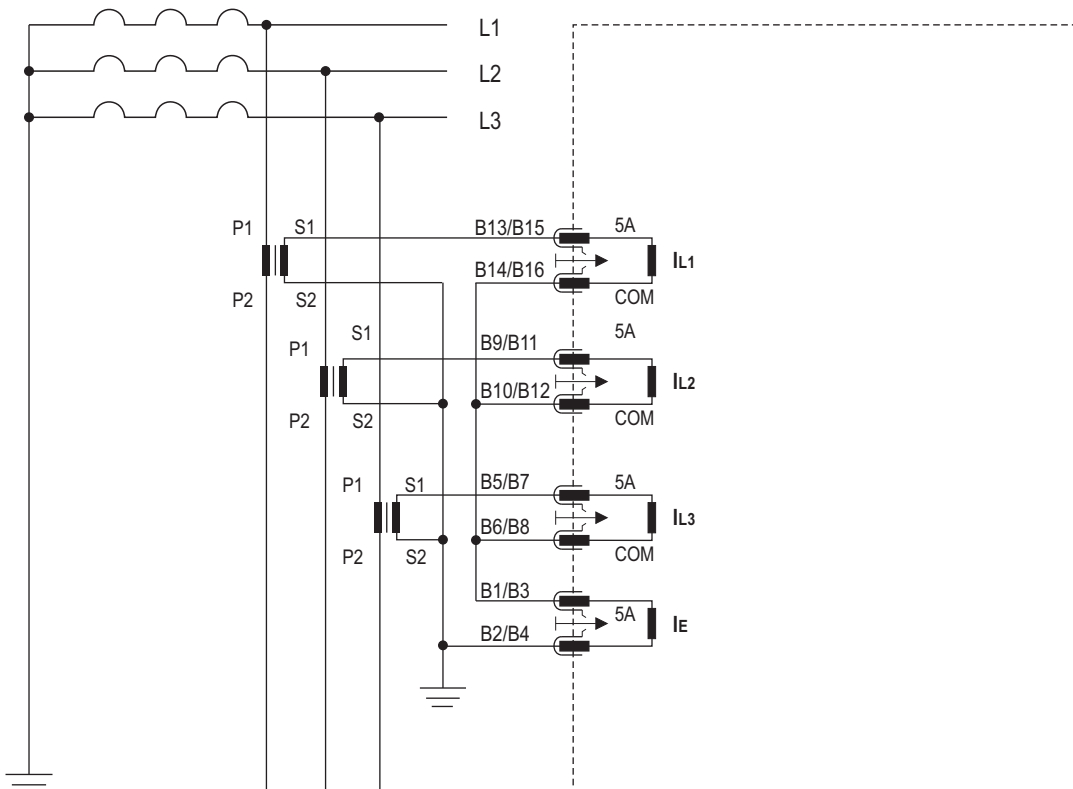

(Figure 11)

19e) Trip Circuit Supervision Diagram

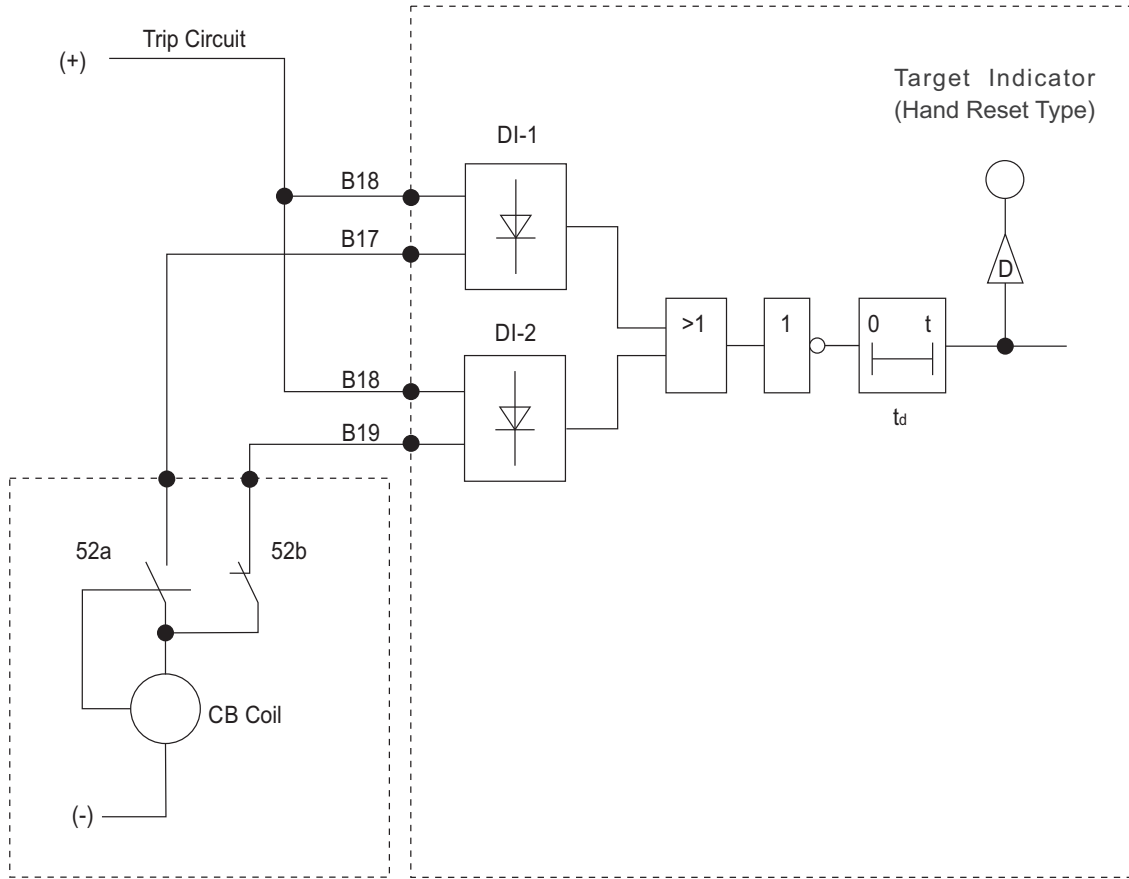

(Trip Circuit Supervision Function)

(Figure 12)

20) Draw-out process of the Relay

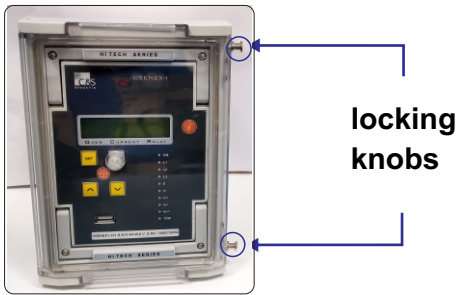

← User(s) are advised to sidelift both the locking knobs gently one by one to open the front cover as shown in the left picture and then Slide side the front cover towards the left side.

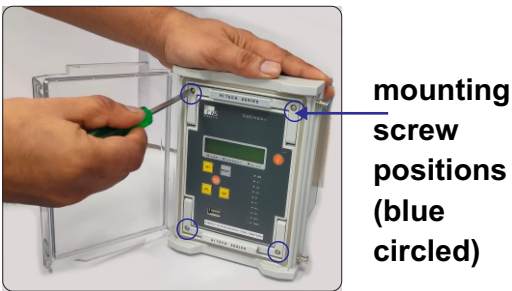

← Now unscrew all the 4 screws placed at the 4 corners of the relay, by using the appropriate screw driver gently, extra force may cause the damage in the relay.



← Hold the Eject handle, as shown in the left picture. Twist the eject handle as shown in the picture.



← Then bring out the relay from the enclosure by using the eject handle.

NOTE : Photos shown here are for general idea of draw out process and can be change in future without prior information.

21) Dimensional Details (Vertical Model)

All the Dimension are in mm (Gen Tol.: $\pm 1\text{mm}$)

The Hi-Tech NEX Series Relay has been equipped with in-built press-fit mechanism. Without using any additional mounting accessories, the Relay can be easily flush mounted on the panel.

With appropriate mounting accessories the Relay can be mounted through panel cut-out for flush mounting:

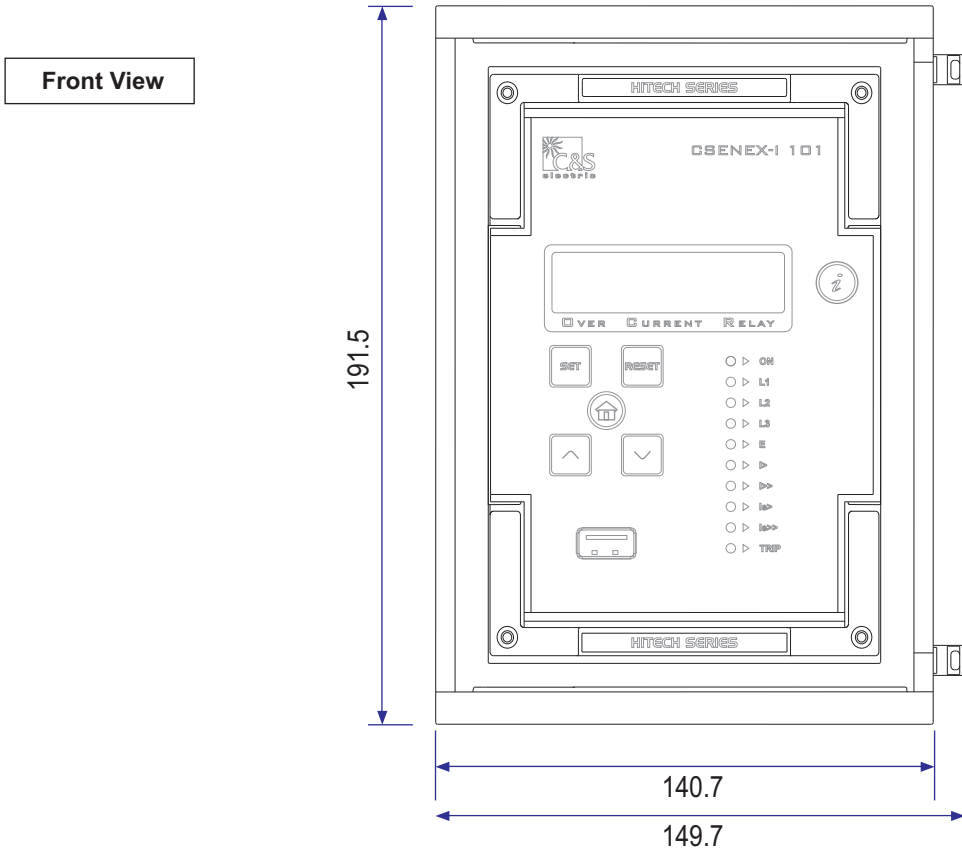

(Figure 13)

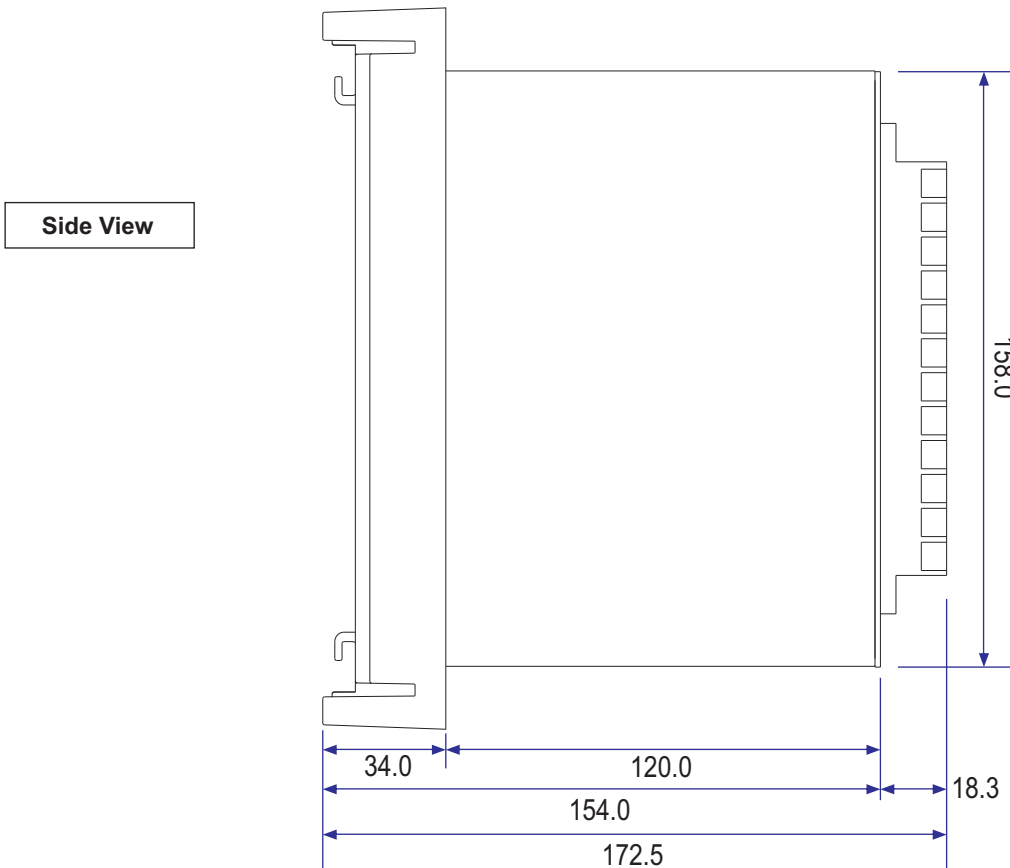

(Figure 14)

Dimensional Details contd..

Back View

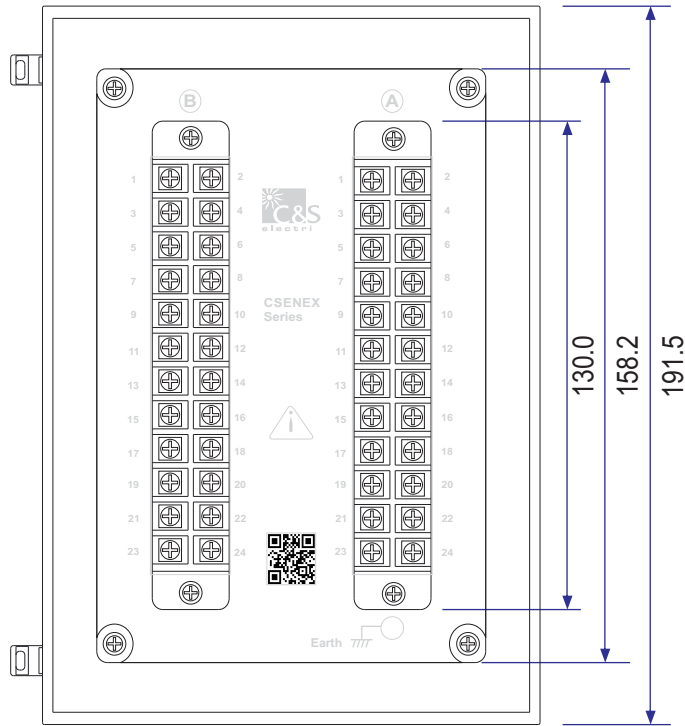

(Figure 15)

Top View

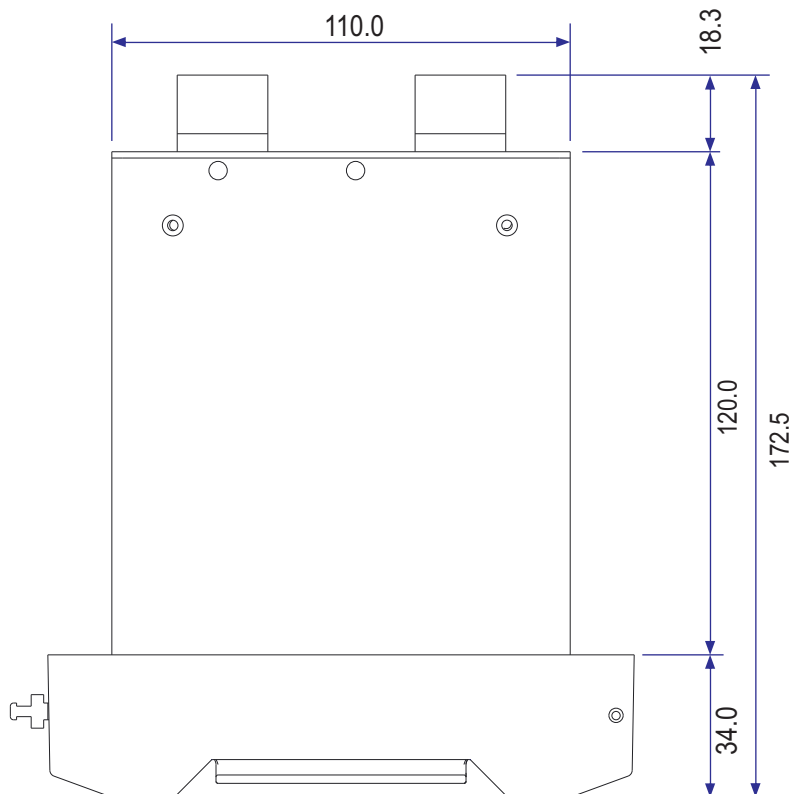

(Figure 16)

22) Mounting arrangement of the Relay

Back View

Back Terminal numbering of CSENEX-I 101/150

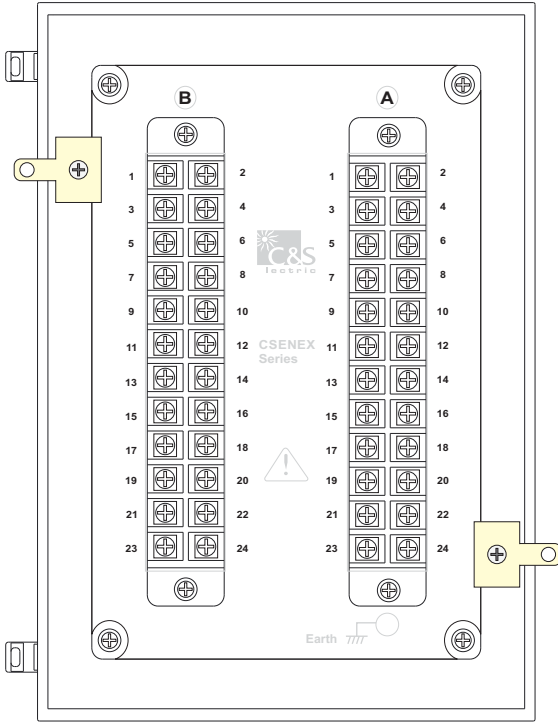

(Figure 17)

Back Terminal numbering of CSENEX-I 350

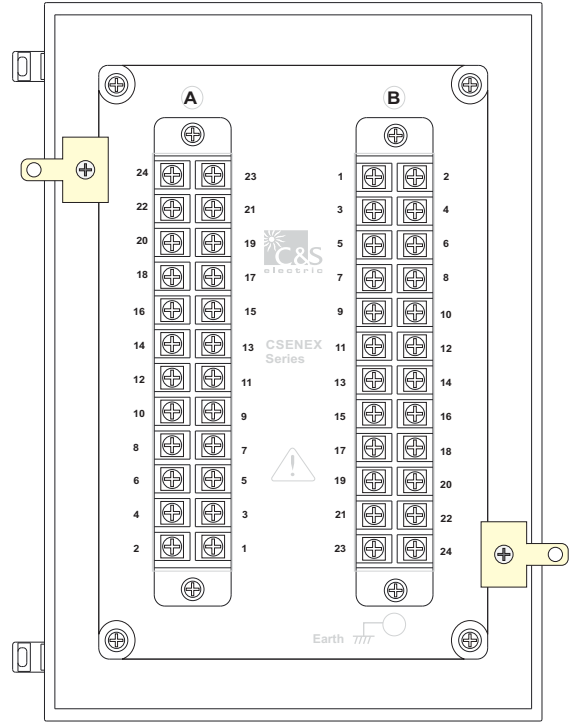

(Figure 18)

Side View

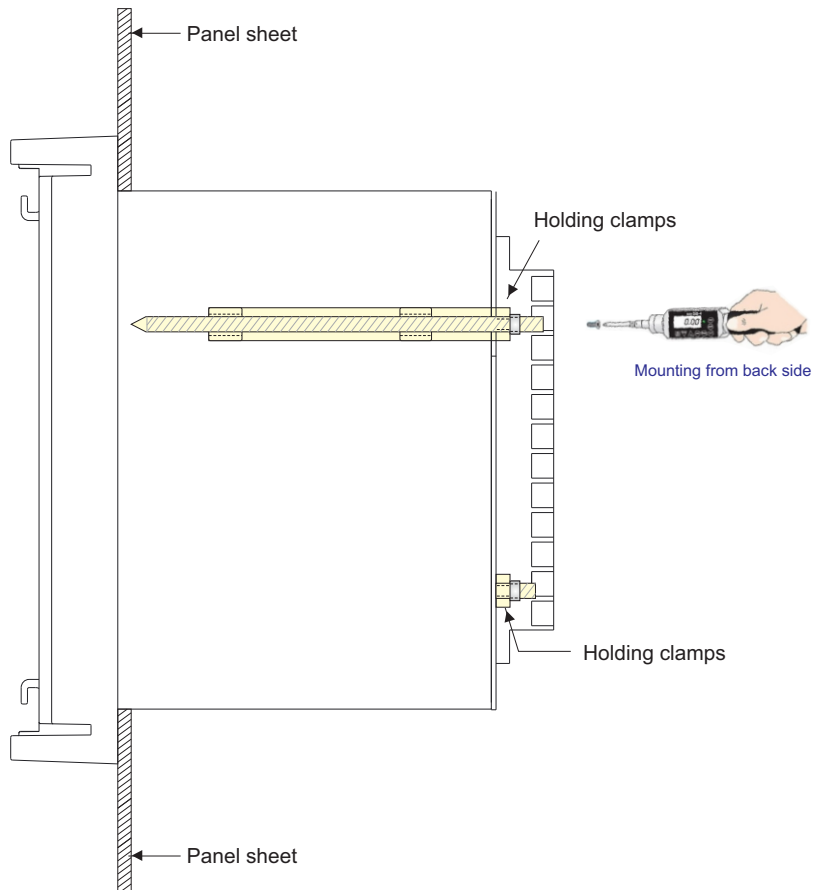

(Figure 19)

23) Panel mounting of the relay

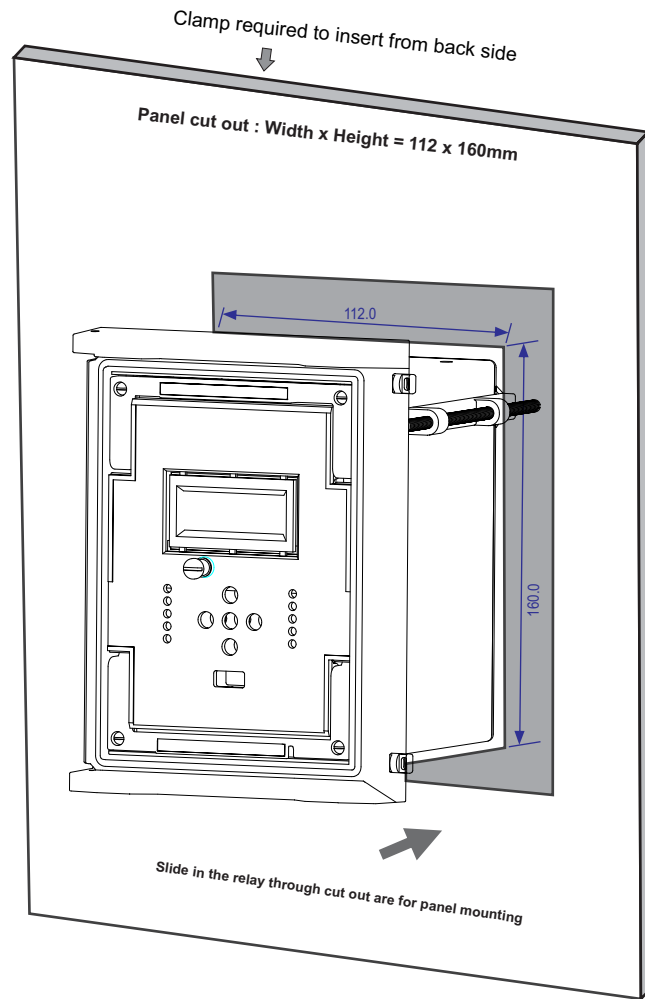

(Figure 20)

24) Ordering Information

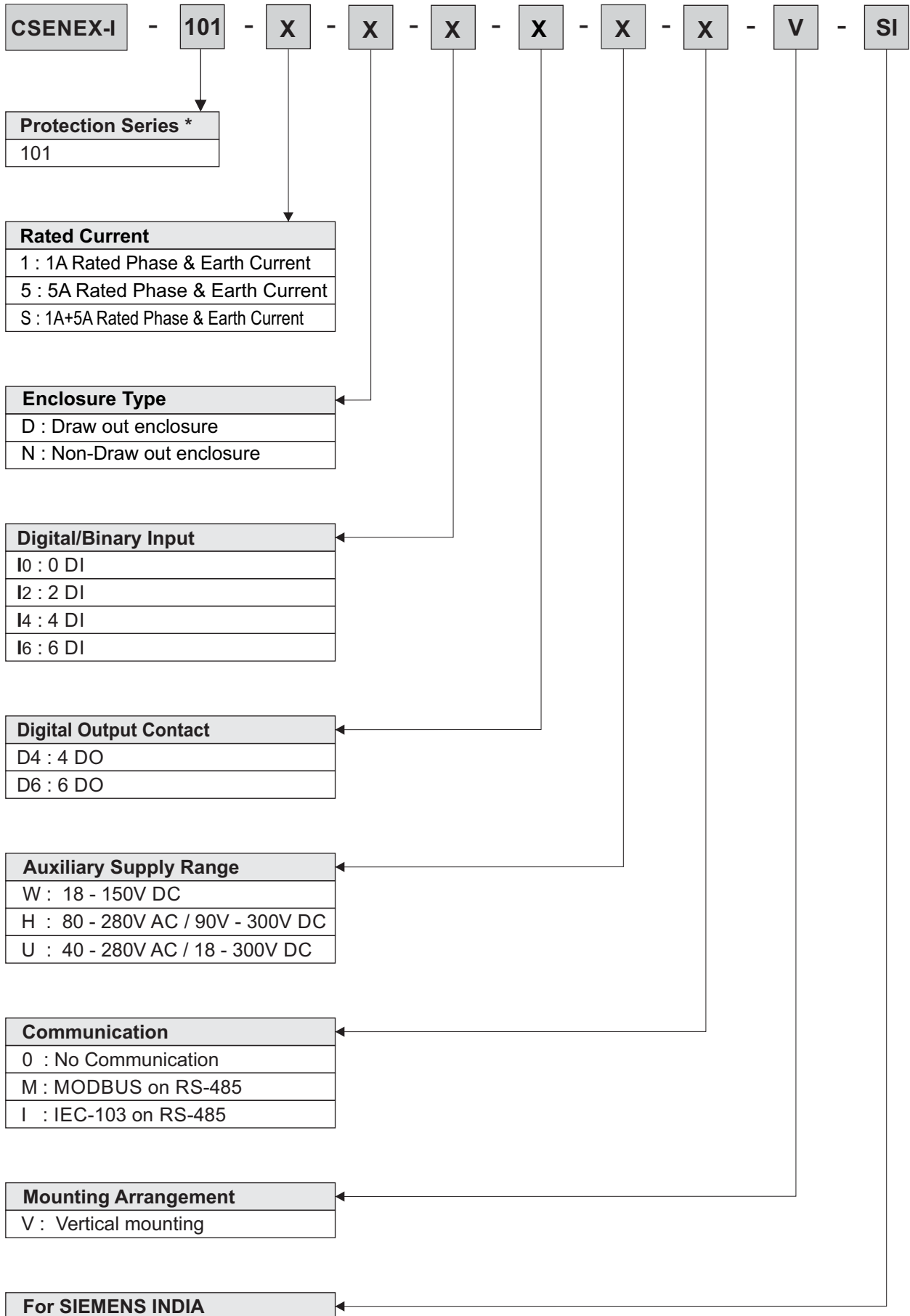

* Protection model; Refer Table-A

25) Ordering Information

CSE NEX-I - X - S - D - X - X - X - X - V - SI

Protection Series *
150
350

Rated Current
S : 1A+5A Rated Phase & Earth Current

Enclosure Type
D : Draw out enclosure

Digital/Binary Input
I4 : 4 DI
I6 : 6 DI

Digital Output Contact
D4 : 4 DO
D6 : 6 DO

Auxiliary Supply Range
W : 18 - 150V DC
H : 80 - 280V AC / 90 - 300V DC
U : 40 - 280V AC / 18 - 300V DC

Communication
M : MODBUS on RS-485
I : IEC-103 on RS-485

Mounting Arrangement
V : Vertical mounting

For SIEMENS INDIA

* Protection model; Refer Table-A

