

We touch your **electricity** everyday!

CSEZEN- F 600-H

■ Advance Feeder Protection & Monitoring IED



DRAW-OUT
WITH SELF
CT SHORTING

FAULT EVENT
DISTURBANCE
RECORDER

DI/DO
PROGRAMMABLE
MATRIX

METERING
PROTECTION

Catalog

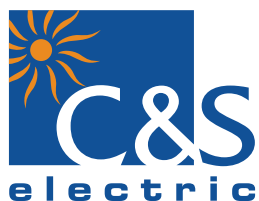

PMD Division

CONTENTS

S.No.	Description
1.	Introduction
2.	Application
3.	Hardware
4.	Protection Features
5.	Supervision Functions
6.	Functional Diagram
7.	Protection Functions
8.	Data Acquisition Functions
9.	Fault Record
10.	Event Record
11.	Disturbance Record
12.	Communication
13.	Human Machine Interface
14.	Setting Ranges
15.	Technical Data
16.	Standards
17.	Recommended Terminal Lugs Specifications
18.	Connection Diagram
	18.1 Terminal Description
	18.2 VT Conn. Diagram
	18.2a (CT Conn Diagram (1A)
	18.2b (CT Conn Diagram (5A)
	18.3 Conn Diagram for Restricted Earth
	18.4 Trip Circuit Supervision Diagram
19.	Dimension Details
20.	Panel mounting of the Relay
21.	Ordering Information

1.0 Introduction

CSEZEN series offers a multi functional comprehensive smart protection solution for Feeder, Generator, Motor & Transformer segment.

CSEZEN family of protective relays are advance numerical relays that provide multi protection and monitoring with reliable and fast protection solution in a single unit.

In this family of CSEZEN series, the CSEZEN-F is an advanced Feeder protection relay designed for controlling, protecting and monitoring industrial installations, public distribution networks and substations.

CSEZEN-F also provides an automation solution of power control. It complies with IEC 60870-5-103, IEC 61850, Modbus protocol for high integration of protection & control. CSEZEN-F offers following features in a compact & smart flush mounting enclosure.

- Programmable Rated Current 1A & 5A
- Measurement, Protection & Metering
- Draw-out enclosure have modular design with CT shorting
- Communication (Local & Remote)
- DI/DO/LED Matrix Programmability
- Intelligent key for DI & DO status, details of fault pickup & status of last fault occurred
- Last 20 fault record (non-volatile memory) with time stamp
- Last 500 event record (non-volatile memory) with time stamp
- Disturbance Recording
- CSEZEN-F relays are equipped with self supervision function

2.0 Application

CSEZEN-F relay will cover wide range of protection functions required for feeder segment. It can be used as part of protection scheme for transformers and generator transformers. CSEZEN-F relays can also provide back-up protection for HV and EHV transmission systems.

3.0 Hardware

- Digital Signal Processor based numeric design
- Measures true RMS with DFT filter
- 1A & 5A site selectable
- CT Terminal with self shorting
- 4 Current Analog Input
- 4 Voltage Analog Input **
- Max.16 Digital Inputs
- Max.16 Digital Outputs
- 10 LEDs at Pickup & Trip on fault
- LAN-RJ45/RS-485/USB ports for Communication
- 20x4 Alpha numeric LCD
- 11 Push button on the front for HMI
- USB with Laptop / Pen-drive OTG interface
- Programmable Scheme Logic (PSL)
- Two level password protection

4.0 Protection Features

- Three Phase Time Over Current
- Three Phase Instantaneous Over Current
- Three Phase Under Current
- Three Phase Directional Over Current
- Ground Time Over Current
- Ground Instantaneous Over Current
- Derived Earth Over Current
- Negative Phase Sequence Over Current
- Earth Fault Directional Over Current
- Phase Under / Over Voltage
- Residual Over Voltage / Voltage Unbalance
- Voltage Controlled Over Current
- Restricted Earth
- Power Protection
- Under / Over Frequency
- Broken Conductor Detection
- Auto Re-closer
- Cold Load Pickup
- Thermal Overload
- Harmonic Blocking
- Rate of Change of Frequency
- Synchro check

5.0 Supervision Functions

- Output Relay Latching
- Open-Close Breaker Command
- Trip Circuit Supervision
- Circuit Breaker Failure
- Switch On To Fault
- VT Supervision
- CT Supervision
- Selective Relay Scheme Logic

6.0 Functional Diagram

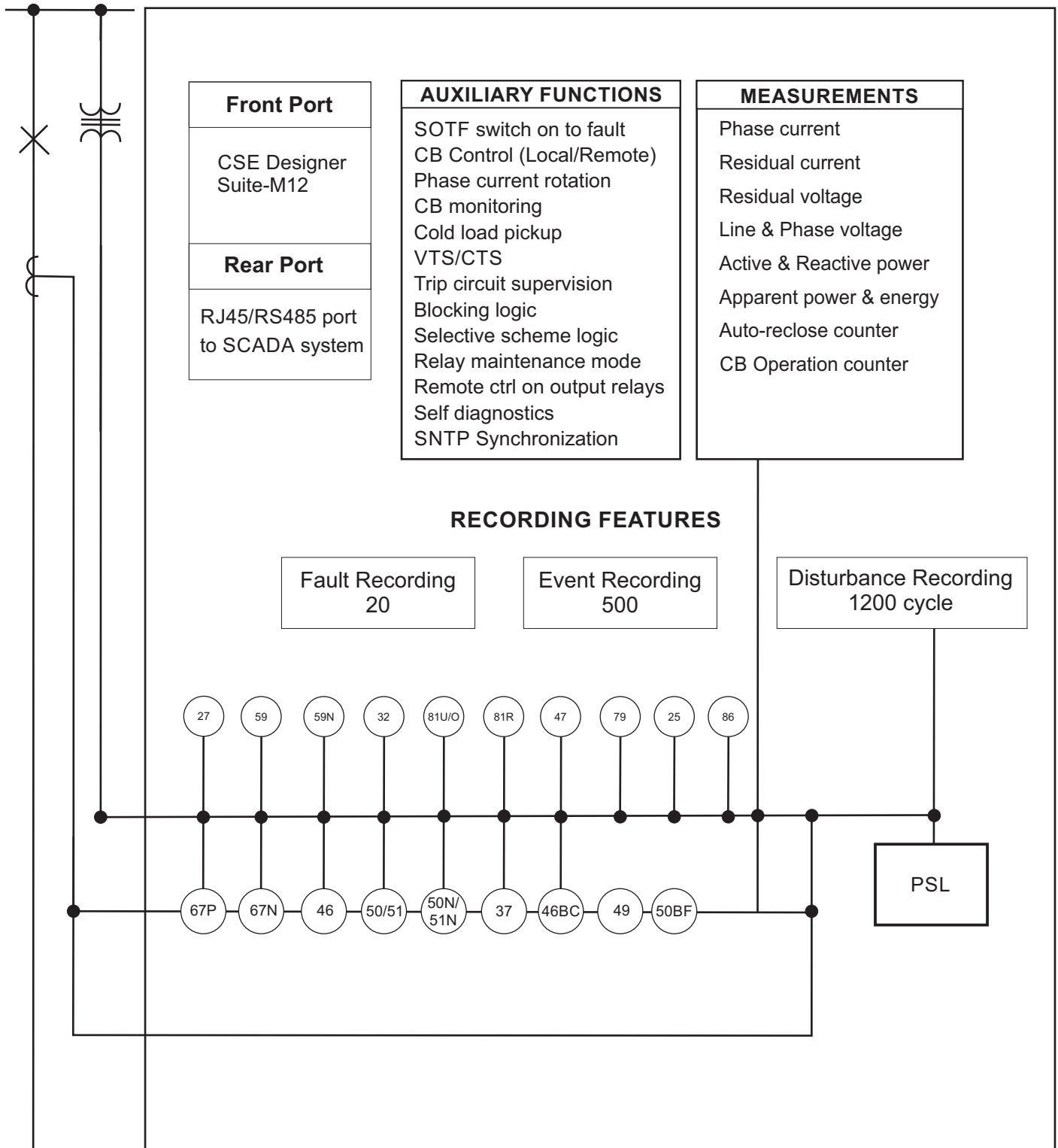

7.0 Protection Functions

Three Phase Over-current

Three Phase over current element (50P/51P) operates in a time period that depends on the applied current and on the set curve. The protection element trip when phase current exceeds the set current threshold for the set time.

The independent three stages are available for phase fault protection. For $I>$ & $I>>$ the user may independently select definite time delay or inverse time delay with different type of curves. The third Hi-set stage can be configured with definite time only.

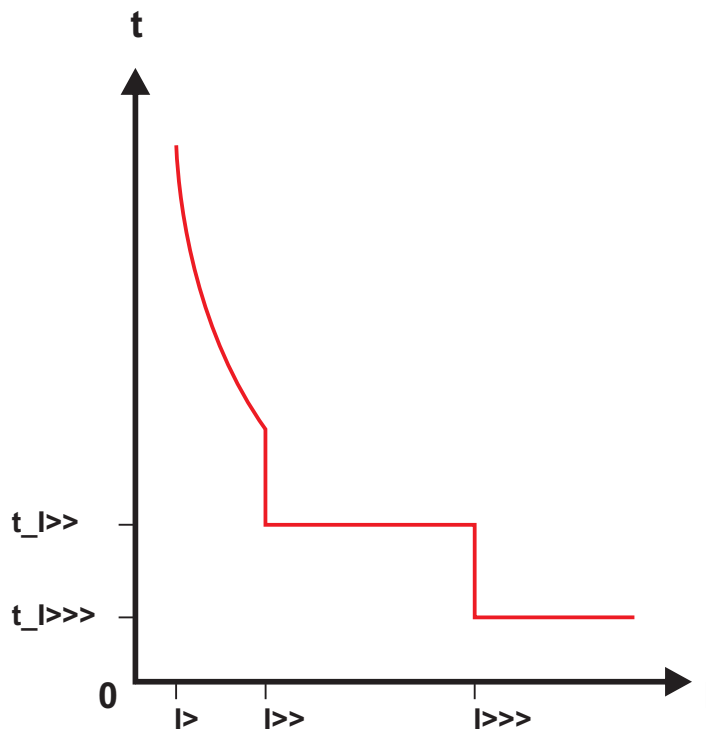

Over current Element

Inverse Characteristics Formula

Refer following formula for EINV, VINV, LINV, NINV1.3, NINV3.0 characteristics:

$$\text{Very Inverse} \quad t = \frac{13.5}{(I / I_s) - 1} \quad t_i \text{ [s]}$$

$$\text{Extremely Inverse} \quad t = \frac{80}{(I / I_s)^2 - 1} \quad t_i \text{ [s]}$$

$$\text{Long time Inverse} \quad t = \frac{120}{(I / I_s) - 1} \quad t_i \text{ [s]}$$

$$\text{Normal Inverse 3.0/1.3/0.6} \quad t = \frac{0.14/0.061/0.028}{(I / I_s)^{0.02} - 1} \quad t_i \text{ [s]}$$

Where t =Tripping time t_i =Time multiplier
 I =Fault current I_s =Setting value of current

Phase Directional Element

The Phase directional element provides independent elements for each phase and determines the direction of the current.

Its main function is to apply a blocking signal to the over current elements to prevent their operation when the current is flowing in a certain direction. In order to determine the direction of the current, the element uses phase current values as operation magnitude and phase-to-phase voltage values as polarization magnitude. This means that in order to polarize a phase, we use the phase-to-phase voltage of the other two phases known as crossed polarization.

Feature : This setting allows enabling or disabling the corresponding directional element.

MTA : The MTA setting corresponds to the Torque angle, which is the rotation applied To phase-to-phase crossed voltage.

Direction : This setting allows selecting the area for the directional element to operate either forward or reverse.

Polarization Voltage Threshold : This is the minimum voltage considered for the direction calculation. Under this setting, the element will be blocked or behave as non-directional depends on the below settings.

Behaviour below minimum polarization : This setting allows selecting either non directional or block depending on the selection, when applied voltage is less than polarization voltage threshold.

In order to give directionality to an over current relay, it is necessary to provide it with a suitable reference or polarizing signal. The reference generally used is the system voltage, as its angle remains relatively constant under fault conditions. The phase fault elements of the directional relay are internally polarized by the quadrature phase-phase voltages, as listed in the table below:-

Protected Phase	Operating Current	Polarizing Voltage
A Phase	IA	VBC
B Phase	IB	VCA
C Phase	IC	VAB

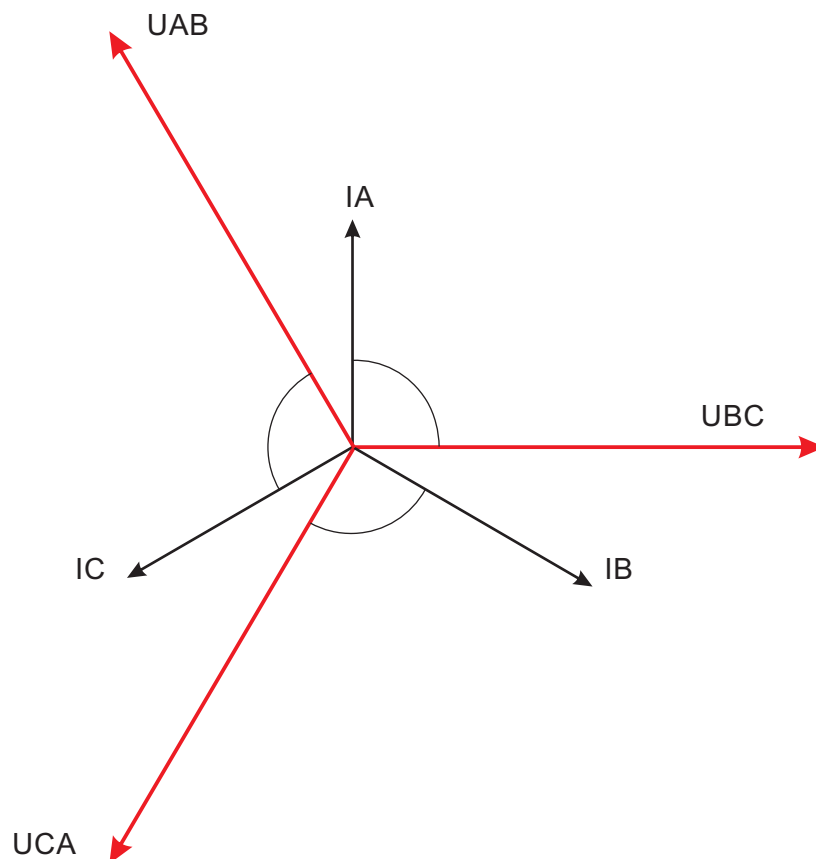

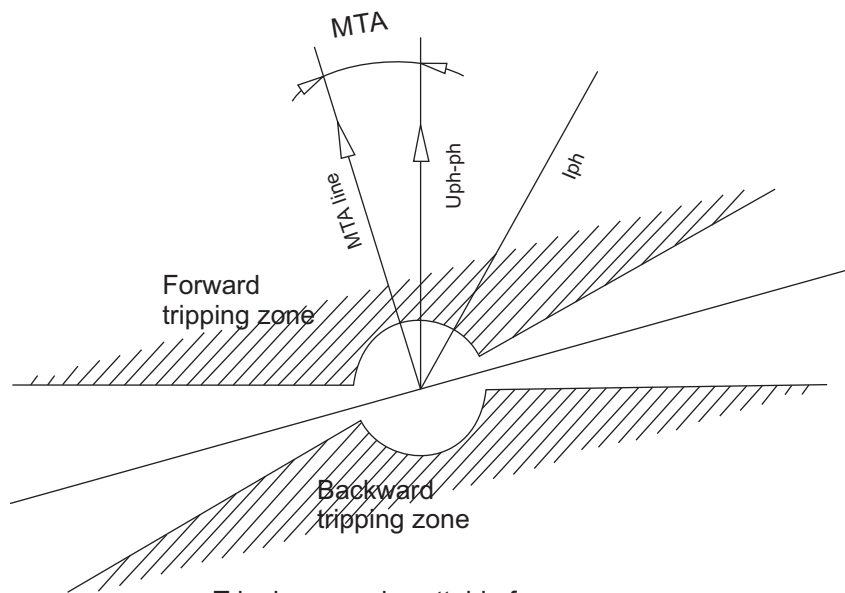

Tripping zone is settable from:-
 $\pm 5^\circ$ to $\pm 175^\circ$ in step of 1° with
 reference to MTA (Torque angle)

MTA (Torque angle) is settable
 from -90° to $+90^\circ$ in step of 1°

The directional element analyze the relation between operating current and reference voltage to determine the fault direction. This is related to the relay characteristics angle (range -90° to $+90^\circ$) as selected by the user. Typically a relay characteristics angle of 45° is chosen for transformer feeders and 30° for plain feeders.

The operate zone is effectively bounded $\pm 90^\circ$ about the system characteristics angle for current levels exceeding the set level.

Earth Over current

The earth current is measured from the earth input terminals B13-B15/B14-B16.

The independent two stages ($I_{e>}$ & $I_{e>>}$) are available for earth fault protection. For first stage ($I_{e>}$) the user can select definite time delay or inverse time delay with different type of curves. The second Hi-Set stage ($I_{e>>}$) can be configured with definite time only.

Derived Earth Over current

The derived earth over current element protection is used to cover application such as HTB/HTA transformers. The derived earth current (I_{e_d}) is the vector summation:

$$I_{e_d} = (I_{L1} + I_{L2} + I_{L3})$$

The derived earth over current has two independent thresholds: I_{e_d} and $I_{e_d} >$.

Directional Earth Fault Protection

Earth directional is a directional protection element used for monitoring the earth over current element.

The operation magnitude is the earth current measured directly from the corresponding input B13-B15/B14-B16, while the polarization magnitude is the residual voltage U_0 . Polarization voltage is calculated from the three phase voltages using algorithm $U_0 = 1/3[U_{L1} + U_{L2} + U_{L3}]$.

The direction is evaluated using the earth current with the U_0 as polarization voltage for the earth fault directional protection. The angle determines the range in which the fault is considered forward and reverse.

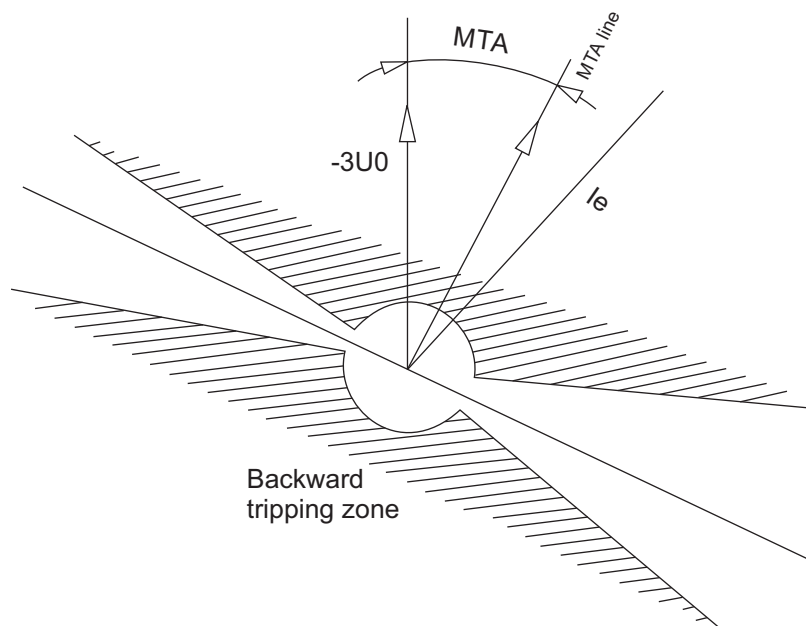

Tripping zone is settable from:-
 $\pm 5^\circ$ to $\pm 175^\circ$ in step of 1° with
 reference to MTA (Torque angle)

MTA (Torque angle) is settable
 from -90° to $+90^\circ$ in step of 1°

Restricted Earth Protection

The restricted earth fault relay is high impedance differential scheme which balances zero sequence current flowing in the transformer neutral against zero sequence current flowing in the transformer phase windings. Any unbalance for in-zone fault will result in an increasing voltage on the CT secondary and thus will activate the REF protection.

This scheme is very sensitive and can then protect against low levels of fault current in resistance grounded systems where the earthing impedance and the fault voltage limit the fault current.

In addition, this scheme can be used in a solidly grounded system.

Negative Phase Sequence Over current

This function protects against current unbalances resulting from anomalies in the power System or unbalanced loads. Negative phase sequence over current element give greater sensitivity to resistive phase to phase faults, where phase overcurrent element may not operate.

If I_2 is Negative phase sequence current then

$$3 \cdot |I_2| = |I_a + a^2 \cdot I_b + a \cdot I_c| \quad \text{Where } a = 1 \angle 120^\circ$$

The Trip can be time delayed by a curve selectable by settings.

Refer following formula for the inverse characteristics of Negative Phase Sequence protection: -

Negative Phase Sequence Equation

$$t = \frac{K1}{(I_2/I_{2s})^2 - 1}$$

K1 : TMS for Inverse characteristics of NPS

t : Expected Trip Time

I_2 : Measured negative sequence value

I_{2s} : Permissible NPS value

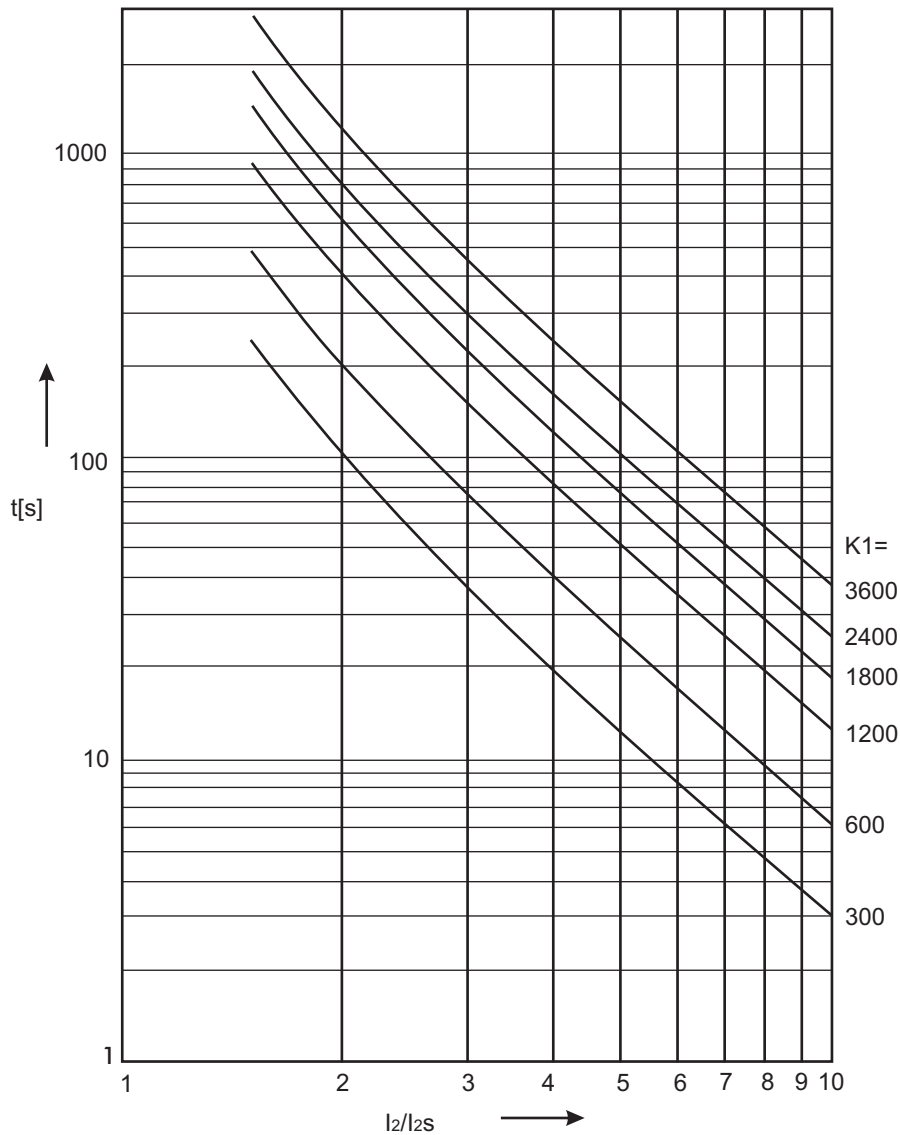

Negative Phase Sequence Inverse Time Characteristics

7) Three Phase Under current

The undercurrent protection makes it possible to detect a loss of load (for example the draining of a pump or breakage of a conveyor belt). If the phase current goes below the programmed undercurrent threshold for a programmed definite time the trip signal is given.

8) Thermal Over load Protection

Thermal overload protection can be applied to prevent damages to the electrical plant equipment when operating at temperatures in excess of the designed maximum withstand. A prolonged over loading causes excessive heating, which may result in premature deterioration of the insulation or in extreme cases, insulation failure.

CSEZEN relays incorporate a current based thermal replica, using load current to reproduce the heating and cooling of the equipment to be protected. The element thermal overload protection can be set with both alarm and trip stages.

The heating within any plant equipment, such as cables or transformers, is of resistive type

($I^2R \times t$), thus the quantity of heat generated is directly proportional to current squared (I^2). The thermal time characteristics used in the relay is based on current squared, integrated over time.

The CSEZEN relays automatically use the highest phase current as input information for the thermal model. Thermal protection can be inhibited on start-up. The thermal time characteristic is given by following formula:-

The formula for calculating the trip characteristics is as follows:

$$\text{Trip time (taus)} = \tau \ln \left[\frac{\left(\frac{I^2}{I_b^2} \right) - p^2}{\left(\frac{I^2}{I_b^2} \right) - k^2} \right] \quad \text{for } p^2 < \frac{I^2}{(I_b^2)} \text{ n } p^2 \leq k^2$$

with τ = thermal time constant of the object to be protected.

I_b = Basic current

I_p = Initial load current

P = Initial load factor ($p=0$ means cold operating component)

k = constant

for thermal characteristics user has two choices

(1) Thermal based on highest measured RMS current

OR

(2) Thermal based on positive & negative sequence measured.

$$I = \sqrt{I_1^2 + \text{Neg}_k \times I_2^2}$$

where

I_0 = Zero phase sequence current (ZPS)

I_1 = Positive phase sequence current (PPS)

I_2 = Negative phase sequence current (NPS)

Neg_k = is weighting factor of NPS (constant value)

In CSEZEN relay three modes are available for saving of thermal memory during power reset. These modes are programmable.

M1: On Power Reset thermal memory becomes 0.

M2: On Power Reset thermal memory starts from the same value as at the time of Power Off.

M3: On Power Reset thermal memory subtracts for the time it is in Off state & starts from the remaining value.

Presentation of the Trip with variable initial load factor:

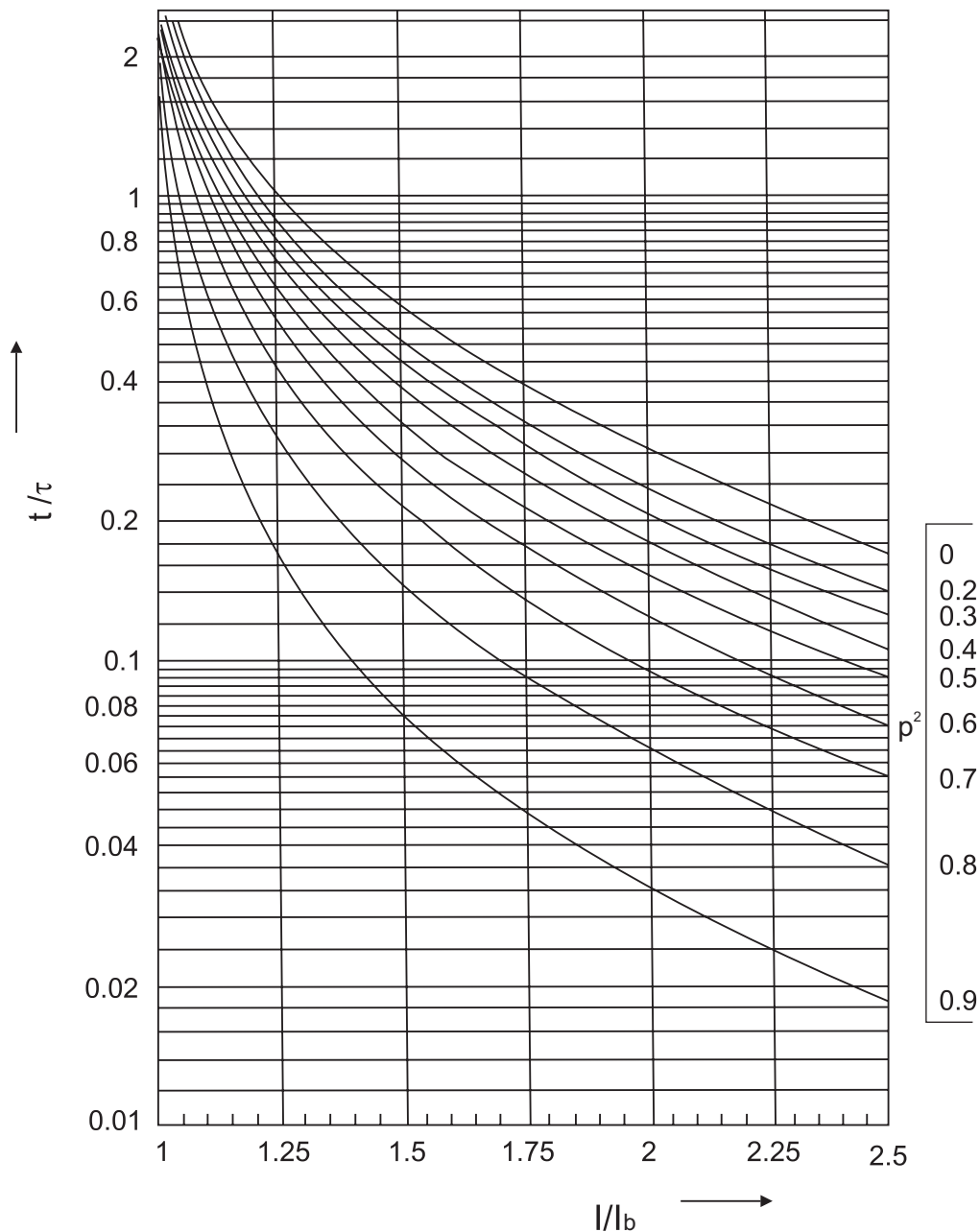

Broken Conductor Protection

Majority of faults on a power system are shunt faults and induce appreciable current increase so easily detectable by standard over current protection element.

Another type of unbalanced system condition is the series or open circuit fault. This fault can arise from broken conductors, mal operation of single phase switchgear or the operation of fuses.

Series faults will not induce an increase in phase current on the system and hence are not easily detectable. However on a lightly loaded line, the negative sequence current resulting from a series fault condition may be very close to or less than the full load steady state unbalance arising from CT errors, load unbalance etc. a negative sequence protection element therefore would not operate at low load levels.

CSEZEN relays incorporate a protection element, which measures the ratio of negative to positive phase sequence current (I_2/I_1). This protection element will be affected to a lesser extent than the measurement of negative sequence current alone, since the ratio is approximately constant with variations in load current. Hence a more sensitive setting may be achieved.

Auto Re-closer Strategy

As 80% of faults in overhead lines are transient, the use of the auto recloser is very advantageous. Automatic auto-recloser allows a substation to operate unattended. The number of visits on site to manually reclose a circuit breaker after a fault, can then be substantially reduced. This feature gives an important advantage for substations supervised remotely.

Typically this auto reclose (AR) sequence of Instantaneous Trip(s) and Reclose Delays (Dead times) followed by Delayed Trip(s) provide the automatic optimum method of clearing all types of faults i.e. both Transient and Permanent, as quickly as possible and helps in improving the up time of the network in service.

DI Inputs

- AR Blocking - To block the auto re-closer through remote DI
- CB Close DI - To get the circuit breaker status
- CB Ready - To get the CB ready or to give the closing command

Configurable Outputs:

- 79 AR Close
- 79 Lockout

AR - Blocked

Unit changes immediately to "AR-blocked" status when an external AR Blocking DI is applied or internal EXIT is chosen for AR cycle in HMI. No Auto reclosing is possible in "AR-blocked" status.

Activating of AR

Prior to every AR it is possible to select which kind of tripping (I> or I>>, Ie>, I>>> etc.) will lead to automatic reclosing. This can be separately fixed for each protection.

Dead time (td)

Starts with the off signal of the circuit breaker. No closing command to the circuit breaker is given till expiry of the set dead time.

User programmable dead times are available for each protection trip operation.

The dead time is initiated when the trip output contact resets, the pickup is reset and the CB is open.

The CB close output relay is energized after the dead time has elapsed If CB ready input is present.

The dead time (dead time td1, dead time td2 dead time td3 dead time td4) starts when the feedback on 'CB CLOSE DI' is not available.

Reclaim time (tr)

This is the time during which after switching on or after AR a subsequent reclosing is prevented.

If the number of the set shots is reached, the relay is locked for this time after the last reclosing attempt.

If CB Ready DI is not available relay will not generate closing command.

If the circuit breaker dose not trip again, the auto re-close cycle resets to original STATE-1 at the end of the reclaim time.

After Successful re-closure the relays goes to the lock out state.

- If the protection operates during the reclaim time of the relay:
- either advances to the next AR cycle that is expected in next auto re-close state or if all the programmed re-closer attempts have been accomplished, it locks out.

The reclaim time is started with the automatic closing command.

Once a CB has reclosed and remained closed for a specified time period (the reclaim time), the AR sequence is reinitialized and a successful close output issued. A single common reclaim time is used (Reclaim Timer). when an auto reclose sequence does not result in a Starting Condition for Auto recloser

- 1) AR should be enabled by manual setting.
- 2) AR blocked DI is not available
- 3) Respective protection AR cycle should not in exit condition.

Lock out State:

Lockout state of the breaker means no further attempts to AR in these conditions

- 1) Lockout occurs when all auto re-closure attempts are over and protection operates during the final Reclaim Time.
- 2) If CBFP failure appeared in relay (if CBFP enable).
- 3) At the end of the each reclaim timer if the CB is in the open position (Close DI is not present).
- 4) If a Close pulse of AR relay is given and the CB fails to close through close DI input or expiry of Trip Contact Sense time.
- 5) If a open pulse given to CB and CB fails to open in between Trip Contact Sense time.

In any of these cases, Manual reset will be required to reinitiate the AR.

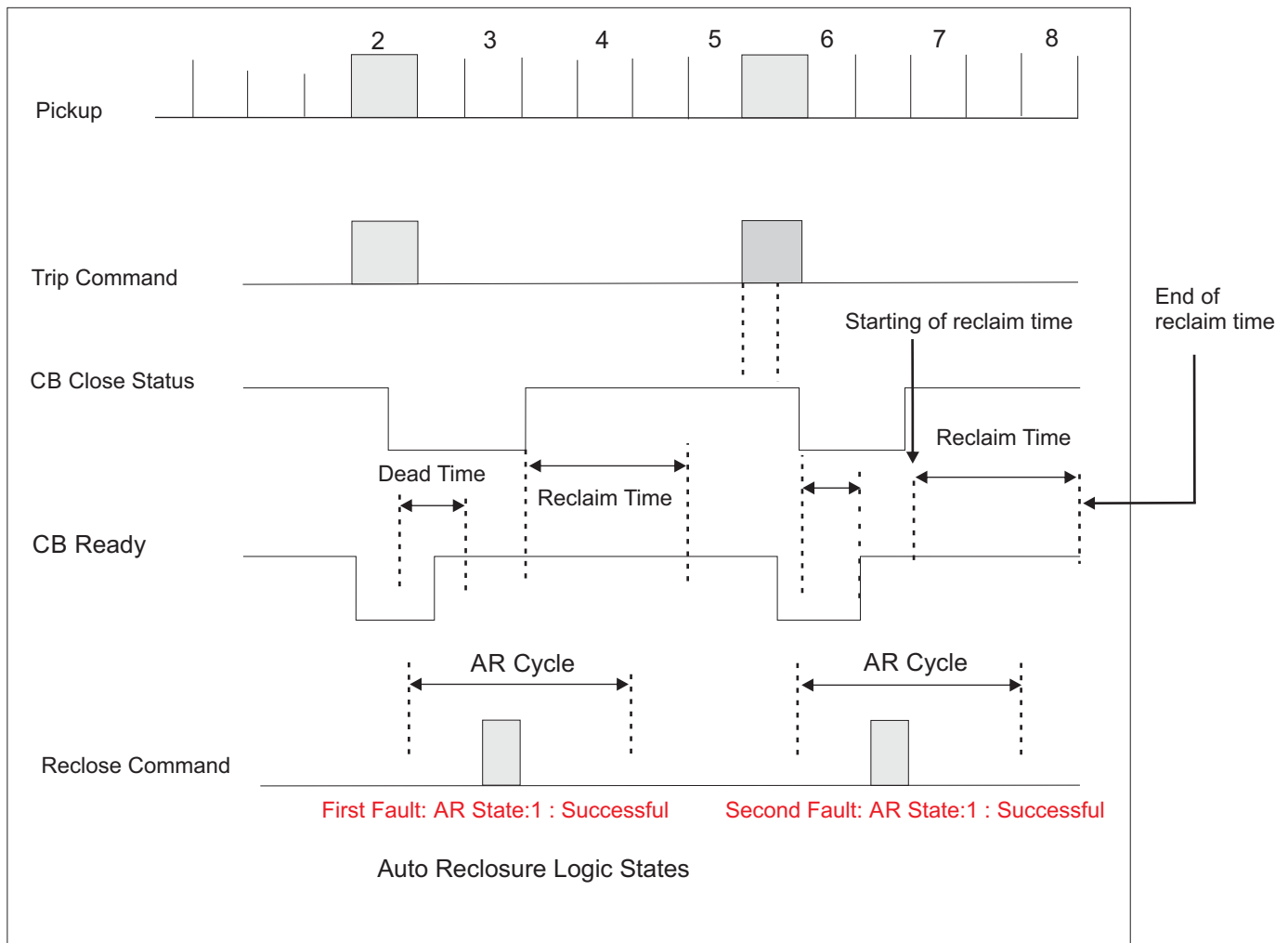

Cold Load Pickup

This function aims to avoid non-desired trips in the following situation: after being the line de-energized for a period of time and re-energized later, the load can exceed the protection setting without the presence of a fault. This may be due to the accumulative inrush current caused when connecting all the loads (furnaces, heaters, coolers etc.) at the same time. CSEZEN relay is detecting when those conditions are given and replacing the active group setting during a programmable time by group4 settings.

In group4 cold load setting will be same as those in active group so in group4 except cold load setting all other protection setting values are programmable.

Voltage Protection

CSEZEN relay are equipped with under voltage, over voltage, Positive phase sequence voltage, negative phase sequence over voltage and zero phase sequence over voltage protections.

a) Under / Over voltage

Under-voltage conditions may occur on a power system for a variety of reasons such as Increased system loading and complete loss of bus-bar voltage whereas over voltage conditions are generally related to loss of load conditions. Under load shedding conditions the supply voltage will increase in magnitude.

Two thresholds are available for under and over voltage function. Each one can be independently activated or deactivated.

b) Zero Sequence Over voltage protection

On a healthy, three phase power system the addition of each of the three phase to earth voltages are normally zero. However, when an earth fault occurs on the primary system this balance is upset. CSEZEN-F relays will operate from the zero sequence voltage, which is calculated internally or from the residual voltage, which is measured directly or internally.

$$\vec{U}_0 = 1/3 | (\vec{U}_{L1} + \vec{U}_{L2} + \vec{U}_{L3}) |$$

Positive Sequence Under voltage protection

This function is based on the positive phase sequence component of the voltage, which is calculated internally.

$$\vec{U}_1 = \frac{1}{3} (U_{L1} + aU_{L2} + a^2U_{L3})$$

When positive phase sequence voltage goes below the programmed positive phase sequence threshold for a programmed definite time the trip signal is given.

Negative Sequence Over voltage protection

Where an incoming feeder is supplying a switchboard which is feeding rotating plant (e.g. induction motor) correct phasing and balance of the AC supply is essential. Incorrect phase rotation will result in any connected motors rotating in the wrong direction. For directionally sensitive applications, such as elevators and conveyor belts, it may be unacceptable to allow this to happen CSEZEN relay will operate from negative phase sequence voltage due to any unbalanced condition occurring on the incoming supply and is calculated internally.

$$\vec{U}_2 = \frac{1}{3} (U_{L1} + a^2U_{L2} + aU_{L3})$$

Refer following formula for IDMT characteristics for over/under voltage

$$t = \frac{\text{TMS}}{(V/V_s) - 1}$$

Where	t	=	Operating time in seconds
	TMS	=	Time multiplier setting
	V	=	Applied Input Voltage
	V _s	=	Relay Setting Voltage

Note: This equation is only valid for V/V_s ratio < 0.95 (for under voltage) and > 1.1 (for over voltage)

Voltage Control Over current Protection

This function reduces the tripping time in case of severe faults due to voltage fall because it lowers the pickup level of the over current unit depending on the voltage level. 51V function means the control of the over current elements by the monitoring of the phase voltage.

This function improves sensitivity of over current unit because changes the pickup level proportional to applied input voltage so it provides better coordination and fault detection. In industry, standard backup over current protection schemes for MV generators fed from switchgear circuit breaker, voltage controlled over current protection is used.

This protection has two modes of operations :-

MODE1: When the control voltage is lower than a programmed value, the function 51 effective settings are no more those programmed in Over current menu but replaced by 51V menu settings.

MODE2: In this mode, controlled pick up current of function 51 varies linearly in the control voltage range of 20-90% of the nominal voltage. For control voltage value higher than 90% of the nominal pick up current is the programmed one for the function 51.

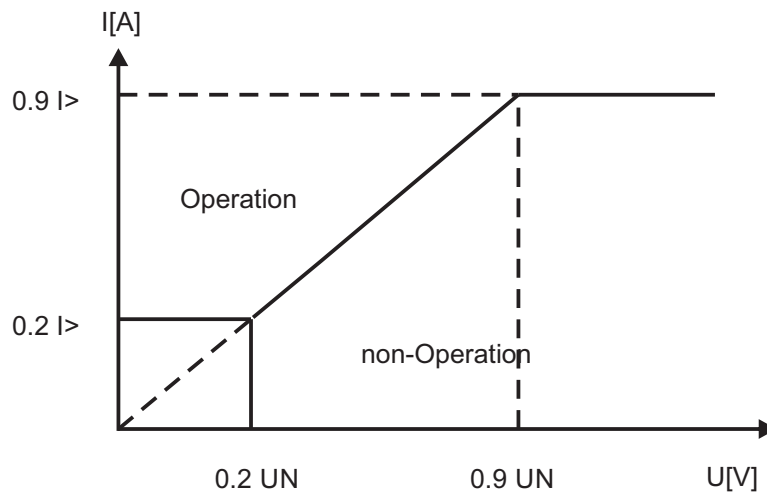

The over current operating characteristics is proportional to the input voltage within the specified voltage range.

Frequency Protection

CSEZEN relay are equipped with under frequency, over frequency and rate of frequency change protection.

a) Under/Over Frequency Protection

This element is used to detect the tendency of the variation of frequency due to severe disturbances performed by load shedding. Two thresholds are available for under and over frequency function. Each one can be independently activated or deactivated.

b) Rate of Change of Frequency Protection

The rate of change of frequency elements are very important to detect any power loss under severe disturbances and eventually perform load shedding of secondary load.

It can also compliment the generator control system to reduce or shed generation when the frequency rises above the nominal frequency at a high rate.

The frequency of change units has two steps; this allows the disconnection of loads before reaching undesired frequency levels.

Power Protection

CSEZEN relay are equipped with under power, over power and reverse power protections.

a) Under Power Protection

It protects against excessive decrease in 3 phase power and it compares the active power with the programmed value of under power threshold .If the measured value of active power is lower than the set value, the protection will trip the corresponding relay.

Any reverse power will be considered below the under power threshold, so it will operate this protection. Two thresholds are available for under power function. Each one can be independently activated or deactivated.

b) Over Power Protection

It protects against excessive increase in 3 phase power and it compares the active power with the programmed value of over power threshold. If the measured value of active power is greater than the set value, the protection will trip the corresponding relay.

Two thresholds are available for over power function. Each one can be independently activated or deactivated.

c) Reverse Power Protection

The protection actuates when the power flow gets reversed and the measured value of active power is greater than the set value, the protection will trip the corresponding relay. Two thresholds are available for reverse power function. Each one can be independently activated or deactivated.

Harmonic Blocking

In the CSEZEN relays, starting of the phase current and earth current stage can be blocked under inrush conditions to avoid unsuitable trip during transformer magnetization.

As soon as the ratio of second harmonic component is above the programmed value (in percentage) then selected over current and earth protection will be blocked for a settable duration.

Circuit Breaker Failure Protection

The CB failure protection is based on supervision of phase currents and earth current after tripping events. The test criterion is whether all phase currents have dropped to less than 5% of Nominal value of rated current within the set time (tCBFP). If one or more of the phase currents have not dropped to specified current within this time, CB failure is detected and the assigned output relay is activated.

Trip Circuit Supervision

This feature detects any anomalies in the circuit with the switch open or close. It detects trip circuit supply failure of circuit breaker, tripping mechanism failure like circuit breaker contact degeneration in wires, contacts and coils.

Output Relay Latching (86)

Any digital output can be latched. Reset of the latched output is possible by logic input front panel operator interface or by remote communication or through RESET key.

Blocking Logic

CSEZEN relay includes logic inputs, which can be configured to block the selected protection functions. Each protection functions can be locked via a digital input as selected and assigned.

Test of Output Relays

Select the TRIP TEST menu from HMI, then by using backward/forward key it will start operating the output relays & LEDs one by one unless the enter key is pressed again.

Local / Remote CB Control

In CSEZEN-F circuit breaker control can be done locally using front keys whereas same can be controlled remotely using configurable DIs as well as communication mode.

Selective Relay Scheme Logic

CSEZEN-F relays include selective logic scheme for various protection functions.

Voltage Transformer Supervision (VTS)

The voltage transformer supervision (VTS) feature is used to detect failure of the analog ac voltage inputs to the relay. This may be caused by internal voltage transformer faults, overloading or faults on the interconnecting wiring to relays. This usually results in one or more blowing.

CSEZEN-F is able to detect a VT loss by using VTS automatism. As soon as VT loss is detected, voltage dependent function Voltage control over current (51V) will be blocked, an alarm can be raised and directional over current functions might be replaced by non-directional over current functions.

VTS automation uses a fixed logic. A VT fault occurs if at least one of the two following conditions is verified.

Negative sequence voltage is greater than $0.3 \times U_n$ and

Negative sequence current is smaller than $0.5 \times I_n$

OR

-Voltage is smaller than $0.1 \times U_n$ and current greater than $0.1 \times I_n$

-The VT fault disappears as soon as one criteria is not valid anymore.

-A VTS alarm occurs when a VT fault occurs during more than set delay time t_{VTS}

only manual reset is applicable for DO assigned to VTS alarm.

Current Transformer Supervision (CTS)

The current transformer supervision feature is used to detect failure of one or more of the ac phase current inputs to the relay. Failure of a phase CT or an open circuit of the interconnecting wiring can result in incorrect operation of any current operated element. Additionally interruption in the ac current circuits risk dangerous CT secondary voltages being generated.

The CT supervision feature operates on detection of derived zero sequence current, in the absence of corresponding derived zero sequence voltage that would normally accompany it.

A CTS alarm will occur when a CT fault (zero sequence current is above set value of $I_0 >$ and below set value of zero sequence voltage $U_0 <$) occur during more than set value of t_{CTS} time delay.

Only manual reset is applicable for DO assigned to CTS alarm.

Switch on to Fault Protection

Under particular conditions, it can happen that when the feeder is supplied by the closing of the CB a fast trip command may be required if a fault is present (closing on to burden).

Some faults may be caused by conditions not removed from the feeder after a reclosing cycle or a manual trip or due to earthed clamps left on after maintenance works. In these cases, it may be desirable to clear the fault condition in fast time, rather than waiting for the Trip time delay associated with the $I >>$ & $I >>>$ protection. t_{SOTF} time delay is used for $I >>$ & $I >>>$ protections in such conditions.

With the switch on to fault (SOTF) submenu, it is possible to shorten the time to trip For $I >>$ & $I >>>$ protection if selected, when for example the relay has detected a fault that is still present on a feeder after energizing.

Setting Group

CSEZEN-F relays have four protection related setting groups. Changes between the groups are executed via the front interface, a dedicated logic input or through the communication port.

To avoid any undesirable tripping, the setting group change is only executed when none of the protection functions are running (deactivated or inhibited).

Phase Current Rotation

In some applications, there is a need to match the plant phase sequence with the connected relay. Without changing the cabling CSEZEN-F relays include the phase rotation feature that allows the setting of the phases in clockwise or in anti clockwise rotation (1-2-3 or 1-3-2 sequence)

Synchro Check (25)

The synchronism element is used for monitoring the connection of two parts of the circuit by the close of a breaker.

This element verifies that voltages (V1 and V2) at both sides of the breaker are within the magnitude, angle and frequency limits set by the user. Where V1 and V2 are the line and busbar voltage values measured by the relay.

The voltage comparison between both sides of a breaker is performed before closing the breaker, in order to minimize internal damage that could occur due to the voltage difference, both in magnitude and angle. This is extremely important in steam generating plants, where re-closing output lines with angle differences could lead to severe damage to the turbine axis.

WARNING

When testing this function, Do not forget that the relay must detect an open breaker to operate.

Time Synchronization

Inside CSEZen there is an internal time clock. Relay supports SNTP Protocol (ordering based). SNTP (Simple network Time Protocol) have mechanisms within the protocol to synchronize the clock and keep it accurate to certain accuracy. The protocol itself has the ability to send commands and re-synchronize the clock so that each attached IED using its synchronization capability on the network is accurate within resolution.. The relay makes the synchronization automatically using SNTP protocol. The internal clock of the relay is synchronized to the UTC time of the NTP server.

8.0 Data Acquisition Function

Measurement

- 3 Phase Current, 3 Phase Star Voltage, 3Phase Delta Voltage, Bus Voltage, Bus Frequency, 3 Phase Active Power, 3 Phase Reactive Power, 3 Phase Apparent Energy, Individual Power Factor, 3 Phase Power Factor, Forward Active Energy, Reverse Active Energy, Forward reactive Energy, Reverse Reactive Energy, Energy Counters (1 Energy Counter is equivalent to 6553.5 Gwh/GVarh) Total Energy Calculation (6553.5 x energy counter + displayed energy) & Line Frequency.
- Earth current measurement
- Derived earth current measurement
- Negative / Positive / Zero phase sequence
- Trip counter
- Thermal memory
- AR cycles
- I_1/I_2 (Positive Phase Sequence current / Negative Phase Sequence current)

9.0 Fault Record

CSEZEN-F records last 20 faults in its non volatile memory with its time stamp. Each record has the following information:

Fault Format		U0	:	XX.XXV	
IL1	:	XX.XXA	U1	:	XX.XXV
IL2	:	XX.XXA	U2	:	XX.XXV
IL3	:	XX.XXA	Power	:	XX.XXW
le	:	XX.XXA	Them_mem	:	XXXX%
le_d	:	XX.XXA	FREQ (Line)	:	XX.XXHz
I2	:	XX.XXA	FREQ (Bus)	:	XX.XXHz
UL1	:	XX.XXV	Dir_Status	:	XXXX
UL2	:	XX.XXV	HR MIN	:	HH:MIN
UL3	:	XX.XXV	SEC Ms	:	Sec: mSec
UL12	:	XX.XXV	DATE	:	DD:MM:YY
UL23	:	XX.XXV	F-TYPE	:	Type of fault
UL31	:	XX.XXV			

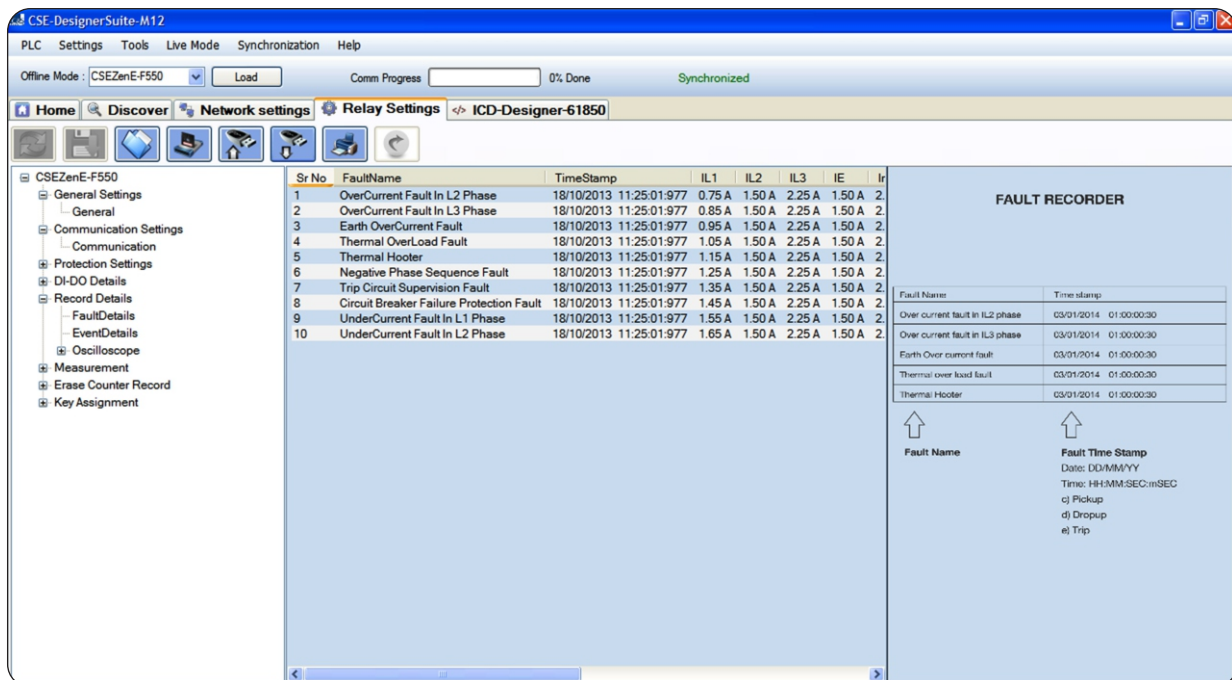

Fault Data recording on PC software

10.0 Event Record

The unit stores in non volatile memory the last 500 events with its time stamp. When the available memory space is exhausted, the new event automatically overwrites the oldest event, which can be retrieved from a PC.

The user can view event records via the front USB interface software.

The screenshot shows the CSE-DesignerSuite-M12 interface. The main window displays a list of events with columns for SrNo, Event Name, EventCategory, and TimeStamp. The event recorder panel on the right shows a table of event details and a legend for event categories.

SrNo	Event Name	EventCategory	TimeStamp
1	Power ON	CONTROL	18/10/2013 11:25:01:30
2	Clock Change	SETTING	18/10/2013 11:25:01:30
3	Circuit Breaker NO contact Close	CONTROL	18/10/2013 11:25:01:31
4	Circuit Breaker NC contact Open	CONTROL	18/10/2013 11:25:01:31
5	Pickup due to Overcurrent in IL1 Phase	PICKUP	18/10/2013 11:25:01:32
6	Pickup due to Overcurrent in IL2 Phase	PICKUP	18/10/2013 11:25:01:32
7	Pickup due to Overcurrent in IL3 Phase	PICKUP	18/10/2013 11:25:01:33
8	Relay Pickup Earth	PICKUP	18/10/2013 11:25:01:33
9	Pickup due to Short circuit in IL1 Phase	PICKUP	18/10/2013 11:25:01:34
10	Pickup due to Short circuit in IL2 Phase	PICKUP	18/10/2013 11:25:01:34
11	Pickup due to Short circuit in IL3 Phase	PICKUP	18/10/2013 11:25:01:35
12	Pickup due to High Earth in E-Phase	PICKUP	18/10/2013 11:25:01:35
13	pickup due to intant short circuit in IL1 Phase	PICKUP	18/10/2013 11:25:01:36
14	pickup due to intant short circuit in IL2 Phase	PICKUP	18/10/2013 11:25:01:36
15	pickup due to intant short circuit in IL3 Phase	PICKUP	18/10/2013 11:25:01:37
16	pickup due to intant high earth	PICKUP	18/10/2013 11:25:01:37
17	Pickup due to negative phase sequence	PICKUP	18/10/2013 11:25:01:38
18	Pickup due to thermal load in IL1 phase	PICKUP	18/10/2013 11:25:01:38
19	Pickup due to thermal load in IL2 phase	PICKUP	18/10/2013 11:25:01:39
20	Pickup due to thermal load in IL3 phase	PICKUP	18/10/2013 11:25:01:39
21	Pickup due to thermal load in E-phase	PICKUP	18/10/2013 11:25:01:40
22	Pickup due to broken conductor	PICKUP	18/10/2013 11:25:01:40
23	Relay dropout due to Overcurrent fault in IL1 Phase	DROPUP	18/10/2013 11:25:01:41
24	Relay dropout due to Overcurrent fault in IL2 Phase	DROPUP	18/10/2013 11:25:01:41
25	Relay dropout due to Overcurrent fault in IL3 Phase	DROPUP	18/10/2013 11:25:01:42
26	Relay dropout due to Overcurrent fault in E- Phase	DROPUP	18/10/2013 11:25:01:42
27	Relay dropout due to short circuit fault in IL1 Phase	DROPUP	18/10/2013 11:25:01:43
28	Relay dropout due to short circuit fault in IL2 Phase	DROPUP	18/10/2013 11:25:01:43
29	Relay dropout due to short circuit fault in IL3 Phase	DROPUP	18/10/2013 11:25:01:44
30	Relay dropout due to high earth	DROPUP	18/10/2013 11:25:01:44
31	Relay dropout due to instant short circuit fault in IL1 Phase	DROPUP	18/10/2013 11:25:01:45

Event Name	Event Category	Time stamp
Power ON	CONTROL	03/01/2014 01:00:00:30
Clock Change	SETTING	03/01/2014 01:00:00:30
Circuit Breaker NO contact close	CONTROL	03/01/2014 01:00:00:30
Pickup due to overcurrent in IL1 phase	PICKUP	03/01/2014 01:00:00:30
Relay dropout due to over current fault in IL2 phase	DROPUP	03/01/2014 01:00:00:30

Event Name	Event Categories	Event Time Stamp
	a) HMI setting	Date: DD/MM/YY
	b) Control	Time: HH:MM:SEC:mSEC
	c) Pickup	
	d) Dropup	
	e) Trip	

Event Data recording on PC Software

11.0 Disturbance Record

The CSEZEN-F relay has an oscillograph data recorder with the following characteristics:

- Oscilloscopic recording can trigger on Pickup or on trip or via DI i.e. change from pre-fault to post-fault stage. It is programmable.
- Each record comprises the samples from max. 8 analog signals (depends upon the different models) and the status of maximum 16 digital inputs and maximum 16 digital outputs. There will be 30 samples per cycle.
- Relay saves maximum 1200 cycles, and the number of cycles per record is programmable which limits the maximum no. of records possible to store in the relay (for example: if 40 cycles are selected, then there will be maximum 30 records of 40 cycles each).
- The pre-fault and post-fault cycles are programmable.
- Records are in the non volatile memory.
- The records are transferred to PC using USB interface. The data is graphically displayed and can be taken on printer.
- Record 1 is always latest record. 2nd record is older than 1st..... and so on.
- Disturbance record is available in comtrade format as per IEC60255-24.



Oscilloscope recording on PC software

Output Contacts

Max. No. of digital outputs	:	16 (DO1, DO2DO16)
Type of outputs	:	Relay
Programmable (DO Assignment)	:	Yes (Max. 15 (DO-2 to DO-16) are programmable and DO-1 is fixed for self supervision function)
Relay reset type	:	Programmable (Auto/Manual)

Input Contacts

Max. No of digital inputs	:	16 (DI1, DI2..... DI 16)
Type of inputs	:	AC/DC Voltage
Programmable (DI Assignment)	:	Yes

12.0 Communication (Local & Remote)

The unit has:

- 1 Front USB port for direct connection to a PC.
- 1 Rear RS-485 communication port.
- 1 Rear terminal can be for: RJ-45

Rear Communication (RS-485)

The protocol for the rear port is based on ordering information. The user can choose either MODBUS or IEC 870-5-103 protocol for RS-485 communication.

Front Communication (USB)

The entire setting including protection parameter setting for both group, Fault, Event & Disturbance record are available on A type USB (female) interface with CSE LIVELINK with saving & printing option.

PHASE OVERCURRENT PROTECTION (50/51)
Three Stage Phase Overcurrent Protection

Parameter Name	Group1	Group2	Group3	Group4	Unit
Over Current Setting					
Phase Characteristics	DEFT	DEFT	DEFT	DEFT	
OverCurrent Setting	0.20	0.20	0.20	0.20	xip
OverCurrent Inverse Timing	0.010	0.010	0.010	0.010	
OverCurrent Definite Timing	0.10	0.10	0.10	0.10	Second
ShortCircuit 1st Stage Setting					
ShortCircuit 1st Stage(I>>) Setting	0.5	0.5	0.5	0.5	xip
ShortCircuit 1st Stage(I>>) Definite Timing	0.02	0.02	0.02	0.02	Second
ShortCircuit 2nd Stage Setting					
ShortCircuit 2nd Stage(I>>>) Setting	0.5	0.5	0.5	0.5	xip
ShortCircuit 2nd Stage(I>>>) Definite Timing	0.02	0.02	0.02	0.02	Second

I> : [1st Stage Over current Protection] Over current Pickup level
 td> : [1st Stage Over current Protection] DEFT Trip Time delay
 I>> : [1st Stage Over current Protection] TMS setting in Inverse characteristic
 I>>> : [2nd Stage Over current Protection] Short circuit Pickup level
 td>> : [2nd Stage Over current Protection] Definite Trip Time delay
 I>>>> : [3rd Stage Over current Protection] I-II-Set Short circuit Pickup level
 td>>>> : [3rd Stage Over current Protection] Definite Trip Time delay
 P.CHAR: Tripping Characteristics [DEFT/INV/NN/VE/M]

13.0 Human Machine Interface

CSEZEN-F offers a variety of front user interfaces, including:

Human-Machine Interface (HMI)







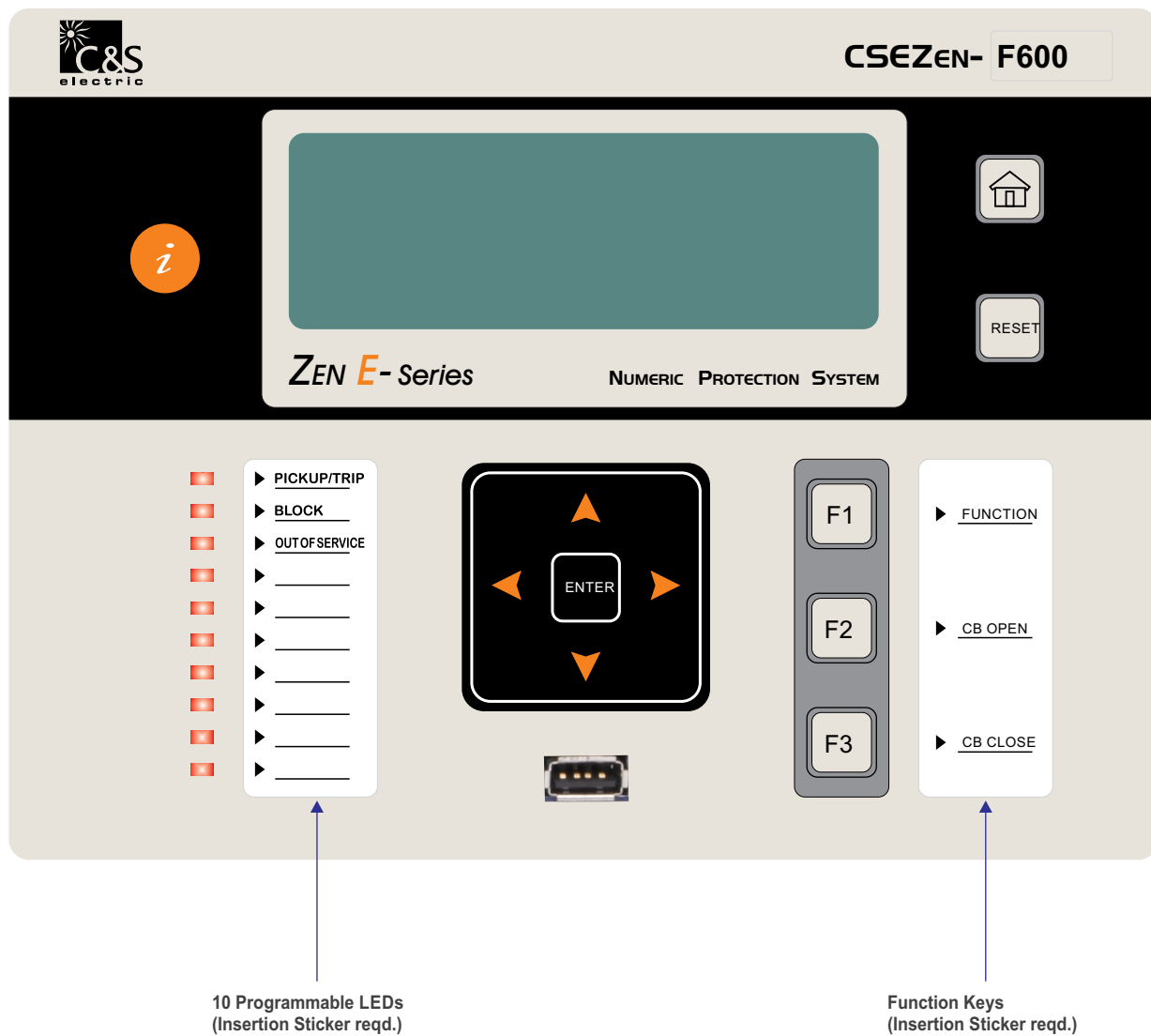



It comprises of 20x4 Alpha numeric display and 11 push buttons for setting and other operations for local access:

- Two push switches for set values of normal tripping characteristics.
- One RESET push switch & One ENTER push switch.
- One intelligent (I) Key.
- One push switch for the tripping of relay assigned to F1 Key.
- Two push switches for the tripping of relay assigned to Circuit breaker open & Circuit breaker close.
- Ten LEDs for pickup or tripping on faults & events in any phase.

In order to change any setting first press enter then only (◀/▶) key will act as decrement/increment else these key will function as scroll in backward/forward direction.



Key Description

Keys	Manual Key
	is used as intelligent key to see the details of the fault pickup / digital input / output status & last fault details / LED Status.
	is used as a HOME key.
	is used as a RESET key.
	is used as a ENTER key.
	is used to scroll in upward direction for parameters.
	is used to scroll in downward direction for parameters.
	is used to scroll in backward direction and for decrement of parameters.
	is used to scroll in forward direction and for increment of parameters.
	is used as a FUNCTION key.
	is used as a CB Open key.
	is used as a CB Close key.

LED Description

In CSEZEN Relay Ten LEDs are given for pickup or tripping on faults & events in any phase. 5 LEDs are Fix

- | | |
|-------------------|--|
| 1) HEALTHY | Relay is in Healthy condition |
| 2) BLOCK | Some protection function is blocked |
| 3) PICKUP | Relay is in pickup mode |
| 4) TRIP | Relay is in Trip mode |
| 5) OUT OF SERVICE | Relay is in out of service mode (Protection on hold) |

5 LEDs are programmable via front end software CSE Designer Suite - M12, 5 of which are in front fascia. For these 5 LEDs protection function naming sticker is needed to be inserted.

USB Description

CSE Designer Suite - M12

USB port is available as HOST & OTG. PC/Laptop can be interfaced via USB port for connecting with CSE Designer Suite - M12 Front End Software. USB Pen drive can also be connected on this port via OTG cable for downloading / uploading the setting / record details.

Programmable Scheme Logic

In CSEZEN Relays maximum 4 nos. of programmable scheme logic can be configured using the front end interface CSE Designer suite-M12. This interface uses Boolean equations. Flexible logic allows user to create logic diagram to be assigned digital output.

The designed logic is event driven to ensure that protection is not delayed.

The following figure describes the use of protection schemes using the over current pickup & under voltage pickup from downstream relays to block operation of upstream relays using a digital output.

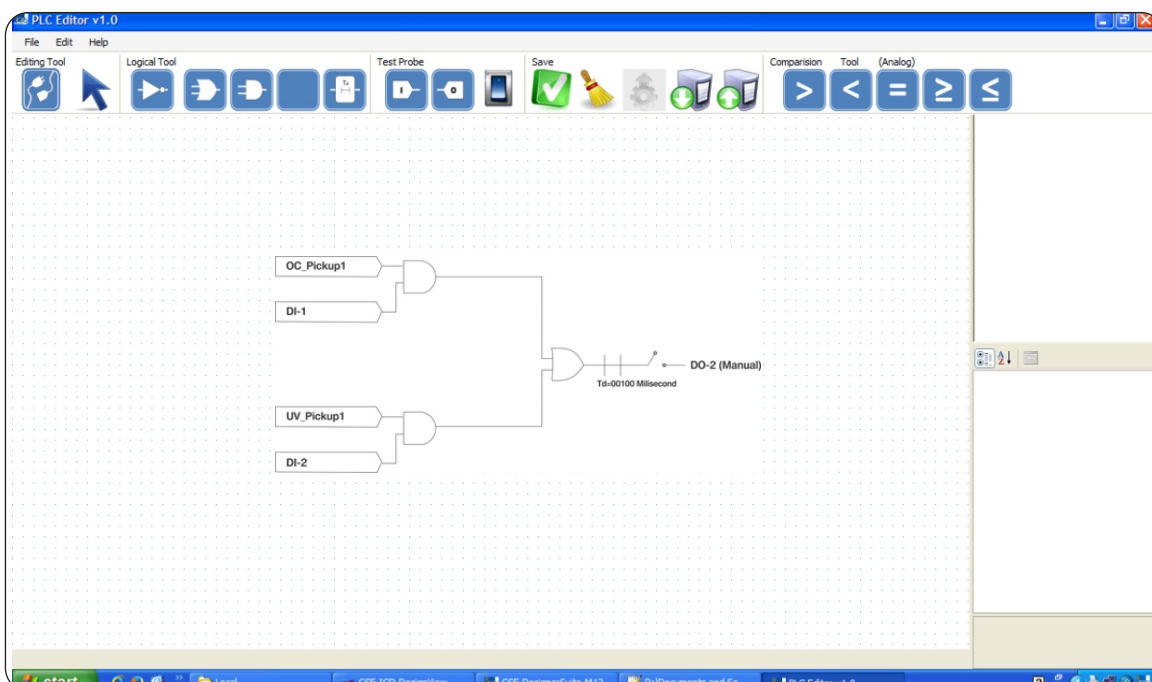

14.0 Setting Ranges

Active Group

Parameters	Display	Setting Range		Step Size	Default Setting
		Min	Max		
Active Group	ACTIVE GROUP	GROUP1	GROUP4	-	GROUP1
Group Toggle Step	TOGGLE STEP	+1	+3	1	+1

(Table-1)

Trip Circuit Supervision Setting

Parameters	Display	Setting Range		Step Size	Default Setting
		Min	Max		
Trip circuit supervision	TCS Deft time	0.03sec	2.00sec	0.01sec	Disable

(Table-2)

Negative Phase Sequence Protection

Parameters	Display	Setting Range		Step Size	Default Setting
		Min	Max		
NPS Trip Characteristic	I2> Characteristics	DEFT	INVERSE	-	DEFT
NPS Pickup Setting	I2> Pickup	0.10xlp	1.00xlp	0.01xlp	Disable
Time Multiple	K1 TD Multiplier	05sec	600sec	01sec	05sec
Definite Time Delay	I2> Deft time	00.1sec	600.0sec	00.1sec	00.2sec

(Table-3)

Earth Fault Protection (These setting will not be applicable if sensitive earth fault protection is available)

Parameters	Display	Setting Range		Step Size	Default Setting
		Min	Max		
Earth characteristic	Curve Type	DEFT	EINV,VINV,LIINV,NINV1.3, NINV3.0, NINV0.6	-	DEFT
Earth pickup setting	Ie> Pickup	0.05xIn	2.5xIn	0.01xIn	Disable
Earth inverse timing	Ie> TD Multiplier	0.010	1.500	0.005	0.010
Earth definite timing	Ie> Deft Time	000.03sec	150.00sec	000.01sec	000.03sec
Earth hi-set pickup setting	Ie>> Pickup	0.50xIn	10.00xIn	0.05xIn	Disable
Earth hi-set definite timing	Ie>> Deft Time	00.02sec	20.00sec	00.01sec	00.02sec
Derived Earth current function	Ie_d> Function	Disable	Enable	-	Disable
Derived Earth current Pickup	Ie_d> Pickup	00.10xIn	15.00xIn	00.01xIn	01.00xIn
Derived Earth current Definite time	Ie_d> Deft Time	00.02sec	100.00sec	00.01sec	00.10sec
Derived Earth current Hi-set function	Ie_d>> Function	Disable	Enable	-	Disable
Derived Earth current Hi-set Pickup	Ie_d>> Pickup	00.10xIn	15.00xIn	00.01xIn	01.00xIn
Derived Earth Hi-set definite time	Ie_d>> Deft Time	00.02sec	100.00sec	00.01sec	00.10sec

Note : Earth Fault protection settings are applicable to REF protection. (Table-4)

Over current Protection

Parameters	Display	Setting Range		Step Size	Default Setting
		Min	Max		
I> pickup setting Stage-1	I>	0.20xlp	5.00xlp	0.01xlp	Disable
Phase trip characteristic Stage-1	PCURVE	DEFT	EINV,VINV,LIINV,NINV 1.3, NINV3.0,NINV0.6	-	DEFT
ti> inverse timing Stage-1	ti>	0.01	1.5	0.005	0.010
t> definite timing Stage-1	t>	000.10sec	150.00sec	0.01sec	000.10sec
I>> pickup setting Stage-2	I>>	0.50xlp	40.00xlp	0.5xlp	Disable
t>> definite timing Stage-2	t>>	000.02sec	20.00sec	0.01sec	000.02sec
I>>> pickup setting	I>>> Pickup	00.50xlp	40.00xlp	0.50xlp	Disable
I>>> definite timing	I>>> Deft Time	00.02sec	20.00sec	0.01sec	00.02sec
SOTF Function	SOTF Function	Disable	Enable	-	Disable
SOTF Definite time	t_SOTF	0.02sec	0.50sec	0.01sec	0.02sec

(Table-5)

Power Protection

Parameters	Display	Setting Range		Step Size	Default Setting
		Min	Max		
Min. active power stage1	Active Power<	NO	YES	-	NO
Min. active power stage1 set value	Active Power< pkup	2 %Pn	200 %Pn	1 %Pn	100 %Pn
Min. active power stage1 time setting	Active Power< Time	0.03sec	60sec	0.01sec	0.3sec
Min. active power stage2	Active Power<<	NO	YES	-	NO
Min. active power stage2 set value	Active Power<< pku	2 %Pn	200 %Pn	1 %Pn	100 %Pn
Min. active power stage2 time setting	Active Power<< Tim	0.03sec	60.00sec	0.01sec	0.03sec
Max. active power stage1	Active Power>	NO	YES	-	NO
Max. active power stage1 set value	Active Power>pkup	5 %Pn	200 %Pn	1 %Pn	100 %Pn
Max. active power stage1 time setting	Active Power>Time	0.03sec	100.00sec	0.01	0.03sec
Max. active power stage2	Active Power>>	NO	YES	-	NO
Max. active power stage2 set value	Active Power>>pkup	5 %Pn	200 %Pn	1 %Pn	100 %Pn
Max. active power stage2 time setting	Active Power>>Time	0.03sec	60.00sec	00.01sec	0.03sec
Reverse power stage1	Reverse Power>	NO	YES	-	NO
Reverse power stage1 set value	ReversePower>pkup	2 %Pn	200 %Pn	1 %Pn	100 %Pn
Reverse power stage1 time setting	ReversePower>Time	0.03sec	60.00sec	00.01sec	0.03sec
Reverse power stage2	Reverse Power>>	NO	YES	-	NO
Reverse power stage2 set value	ReversePower>>pkup	2 %Pn	200 %Pn	1 %Pn	100 %Pn
Reverse power stage2 time setting	ReversePower>>Time	0.03sec	60.00sec	00.01sec	0.03sec

(Table-6)

Phase Directional

Parameters	Display	Setting Range		Step Size	Default Setting
		Min	Max		
I> Directional feature	I> Direction	Disable	Enable	-	Disable
I>> Directional feature	I>> Direction	Disable	Enable	-	Disable
I>>> Directional feature	I>>> Direction	Disable	Enable	-	Disable
MTA Setting	Max. Torque Angle	-90Deg	90Deg	1Deg	0Deg
Direction	Direction	Forward	Reverse	-	Forward
Polarization voltage threshold	Pol Volt Threshold	005Volt	150Volt	1Volt	010Volt
Behavior at less than min. polarization voltage	Beh.Volt Loss	Block	Non-Dir	-	Block

(Table-7)

Earth Directional (These setting will not be applicable if sensitive earth fault protection is available)

Parameters	Display	Setting Range		Step Size	Default Setting
		Min	Max		
Ie> Directional feature	Ie> Direction	Disable	Enable	-	Disable
Ie>> Directional feature	Ie>> Direction	Disable	Enable	-	Disable
MTA Setting	Max. Torque Angle	-90Deg	90Deg	1Deg	0Deg
Direction	Direction	Forward	Backward	-	Forward
Polarization voltage threshold	Pol Volt Threshold	005Volt	150Volt	1Volt	010Volt
Behavior at less than min. polarization voltage	Beh.Volt Loss	Block	Non-Dir	-	Block

(Table-8)

Over Voltage / Under Voltage

Parameters	Display	Setting Range		Step Size	Default Setting
		Min	Max		
Under Voltage Characteristics	UV< Characteristic	DEFT	IDMT	-	DEFT
Blocking on Loss of Voltage	Block On VoltLoss	Enable	Disable	-	Disable
Under Voltage Threshold Setting	UV< Threshold	5 %Un	100 %Un	1 %Un	10 %Un
Under Voltage Pickup Setting	U< Pickup	5 %Un	120 %Un	1 %Un	Enable
Under Voltage TMS Setting	U< TimeMultiplier	0.05	2.00	0.01	0.05
Under Voltage Definite Time	U< Deft Time	00.03sec	20.00sec	0.01sec	00.03sec
Under Voltage Hi-set Pickup Setting	U<< Pickup	5 %Un	120 %Un	1 %Un	Disable
Under Voltage Definite Time	U<<Td	00.03sec	20.00sec	00.01sec	00.05sec
Over Voltage Characteristics	OV> Characteristic	DEFT	IDMT	-	DEFT
Over Voltage Pickup Setting	OV> Pickup	20 %Un	150 %Un	1 %Un	Enable
Over Voltage TMS Setting	OV> TimeMultiplier	0.05	2.00	0.01	0.05
Over Voltage Definite Time	OV> Deft Time	00.03sec	20.00sec	00.01sec	00.05sec
Over Voltage Hi-set Pickup Setting	OV>> Pickup	20 %Un	150 %Un	1 %Un	Enable
Over Voltage Definite Time	OV>> Deft Time	00.03sec	20.00sec	00.01sec	00.05sec

(Table-9)

Over / Under Rate of change of Frequency

Parameters	Display	Setting Range		Step Size	Default Setting
		Min	Max		
Number of cycles under frequency	Pickup Cycle	3	15	1	3
Minimum Voltage	Reqd. Mini. Volt	20Volt	100Volt	1Volt	20Volt
Pickup setting of low under frequency	f< Pickup	40.00Hz	70.00Hz	0.01Hz	Disable
Definite time for low under frequency	f< Deft time	00.00sec	60.00sec	0.01sec	00.02sec
Pickup setting of high under frequency	f<< Pickup	40Hz	70Hz	0.01Hz	Disable
Definite time for high under frequency	f<< Deft time	0.00sec	60sec	0.01sec	0.02sec
Pickup setting of low over frequency	f> Pickup	40Hz	70Hz	0.01Hz	Disable
Definite time of low over frequency	f> Deft Time	00.00sec	60.00sec	00.01 sec	00.02sec
Pickup setting of high over frequency	f>> Pickup	40Hz	70Hz	0.01Hz	Disable
Definite time of high over frequency	f>> Deft Time	0.00sec	60.00sec	0.01sec	0.02sec
DFDT Pickup Cycle	DFDT Pickyp Cycle	2	15	1	4
Direction Setting	Direction	DECREASE	BI-DIRECTION	-	INCREASE
Max. Supervision Frequency Setting	Max. Sup Freq	40.00Hz	70.00Hz	0.01Hz	55.00Hz
Pickup setting of df/dt1 frequency	df/dt1 Pickup	00.20Hz/s	10.00Hz/s	00.01Hz/s	0.2Hz/s
Definite time for df/dt1 frequency	df/dt1 Time	0.00sec	20.00sec	0.01sec	0.02sec
Pickup setting of df/dt2 frequency	df/dt2 Pickup	00.20Hz/s	10.00Hz/s	0.01Hz/s	Disable
Definite time for df/dt2 frequency	df/dt2 Time	0.00sec	20.00sec	0.01sec	0.03sec

(Table-10)

Circuit Breaker Failure Protection

Parameters	Display	Setting Range		Step Size	Default Setting
		Min	Max		
Circuit breaker failure protection time delay	CBFP Deft time	0.03sec	2.00sec	0.01sec	Disable

(Table-11)

U0 / U1 / U2 Setting

Parameters	Display	Setting Range		Step Size	Default Setting
		Min	Max		
Neutral voltage pickup setting	U0> Pickup	2 %Un	100 %Un	1%Un	Disable
Neutral voltage characteristic	U0> Characteristics	DEFT	IDMT	-	DEFT
Neutral voltage TMS setting	U0> TD Multiplier	0.05	2.00	0.01	0.05
Neutral voltage definite time	U0> Deft Time	00.03sec	20.00sec	00.01sec	00.05sec
Positive sequence voltage pickup setting	U1< Pickup	10 %Un	100 %Un	1 %Un	Disable
Positive sequence voltage definite time	U1< Deft Time	00.03sec	10.00sec	00.01sec	00.10sec
Negative sequence voltage pickup setting	U2> Pickup	10 %Un	100 %Un	1 %Un	Disable
Negative sequence voltage definite time	U2> Deft Time	00.03sec	10.00sec	00.01sec	00.10sec

(Table-12)

Harmonic Blocking

Parameters	Display	Setting Range		Step Size	Default Setting
		Min	Max		
Phase 2nd harmonic block	P2ndH	10%If	50%If	1%If	Disable
Earth 2nd harmonic block	E2ndH	10%If	50%If	1%If	Disable
Phase blocking time	tPHASE	00.00sec	20.00sec	00.10sec	00.00sec
Earth block time	tEARTH	00.00sec	20.00sec	00.10sec	00.00sec

(Table-13)

Under Current Protection

Parameters	Display	Setting Range		Step Size	Default Setting
		Min	Max		
Under Current Pickup Setting	I<Pickup	0.20xI _p	1.00xI _p	0.01xI _p	Disable
Under Current Timing	t<	001.00sec	260.00sec	000.01sec	002.00sec
Under Current Threshold	ThrsSet	0.50xI _p	1.00xI _p	0.05xI _p	0.50xI _p

(Table-14)

Sensitive Earth Over Current * (based on Ordering information)

Parameters	Display	Setting Range		Step Size	Default Setting
		Min	Max		
Phase Characteristics	Curve Type	DEFT	EINV, VINV, NINV1.3,LINV NINV3.0, NINV0.6	----	DEFT
I _e > Current Setting	I _e > Pickup	0.002 Amp	1 Amp	0.001 Amp	0.1Amp
I _e > inverse timing	I _e > TD Multiplier	0.01 sec	1.5 sec	0.005 sec	0.1 sec
I _e > Definite timing	I _e > Deft Time	0.03 sec	150 sec	0.01 sec	0.03 sec
I _e >> Current Setting	I _e >> Pickup	0.002 Amp	1 Amp	0.001 Amp	0.1 Amp
I _e >> Definite timing	I _e >> Deft Time	0.03 sec	150 sec	0.01 sec	0.03 sec

(Table-15)

Cold Load Protection

Parameters	Display	Setting Range		Step Size	Default Setting
		Min	Max		
Mode of Trigger	MODE	Cold Load	DI	-	Disable
Cold load time	tcold	00000sec	10000sec	00001sec	00020sec
Cold load pickup time	tcp	0001sec	3600sec	0001sec	0020sec
Inrush percentage setting	I _{f2} /I _{f1}	20%	100%	5%	30%

(Table-16)

Synchro-check

Parameters	Display	Setting Range		Step Size	Default Setting
		Min	Max		
Function Permission	Func perm	Disable	Enable	-	Disable
Voltage Element for sync	REF Voltage	L1/L12	L2,L3/L23,L31	-	L1/L12
Dead bus voltage level	DB Lev1	3Volt	150Volt	0.1Volt	10Volt
Live bus voltage level	LB Lev1	3Volt	150Volt	0.1Volt	50Volt
Dead line voltage level	DL Lev1	3Volt	150Volt	0.1Volt	10Volt
Live line voltage level	LL Lev1	3Volt	150Volt	0.1Volt	50Volt
Voltage Difference	Volt Diff	2Volt	150Volt	0.1Volt	10Volt
Angle Difference	Angle Diff	2Deg	80Deg	1Deg	10Deg
Frequency Slip	Freq Slip	0.01Hz	5Hz	0.01Hz	0.02Hz
Breaker Closing time	CBCIs Tim	0.01sec	300sec	0.01sec	0.5sec
Dead Line - Dead Bus permission	DL-DB Func	Disable	Enable	-	Disable
Live Line - Dead Bus permission	LL-DB Func	Disable	Enable	-	Disable
Dead Line - Live Bus permission	DL-LB Func	Disable	Enable	-	Disable

(Table-17)

DO Assignment Setting

S.No.	Parameters	S.No.	Parameters
1	OverCurrent Pickup	40	Auto Recloser Lockout
2	OverCurrent Trip	41	Synchro check
3	ShortCircuit Stage1 Pickup	42	Circuit Breaker Open
4	ShortCircuit Stage1 Trip	43	Circuit Breaker Close
5	ShortCircuit Stage2 Pickup	44	Over Frequency Pickup
6	ShortCircuit Stage2 Trip	45	Over Frequency Trip
7	Earth Pickup	46	Over Frequency Hiset Pickup
8	Earth Trip	47	Over Frequency Hiset Trip
9	Earth HiSet Pickup	48	Under Frequency Pickup
10	Earth HiSet Trip	49	Under Frequency Trip
11	UnderCurrent Pickup	50	Under Frequency Hiset Pickup
12	UnderCurrent Trip	51	Under Frequency Hiset Trip
13	Derived Earth Stage1 Pickup	52	Rate of Change in Freq Stage1 Pickup
14	Derived Earth Stage1 Trip	53	Rate of Change in Freq Stage1 Trip
15	Derived Earth Stage2 Pickup	54	Rate of Change in Freq Stage2 Pickup
16	Derived Earth Stage2 Trip	55	Rate of Change in Freq Stage2 Trip
17	Negative Phase Sequence current Pickup	56	Under Power Pickup
18	Negative Phase Sequence current Trip	57	Under Power Trip
19	UnderVoltage Pickup	58	Under Power Hiset Pickup
20	UnderVoltage Trip	59	Under Power Hiset Trip
21	UnderVoltage HiSet Pickup	60	Over Power Pickup
22	UnderVoltage HiSet Trip	61	Over Power Trip
23	OverVoltage Pickup	62	Over Power Hiset Pickup
24	OverVoltage Trip	63	Over Power Hiset Trip
25	OverVoltage HiSet Pickup	64	Reverse Power Pickup
26	OverVoltage HiSet Trip	65	Reverse Power Trip
27	Zero Phase Sequence Voltage Pickup	66	Reverse Power Hiset Pickup
28	Zero Phase Sequence Voltage Trip	67	Reverse Power Hiset Trip
29	Positive Phase Sequence Voltage Pickup	68	VTS Alarm
30	Positive Phase Sequence Voltage Trip	69	CTS Alarm
31	Negative Phase Sequence Voltage Pickup	70	Remote Trip1
32	Negative Phase Sequence Voltage Trip	71	Remote Trip2
33	Thermal Relay	72	Remote Trip3
34	Thermal Alarm	73	Remote Trip4
35	Trip Circuit Supervision	74	Remote Trip5
36	Trip Circuit Supervision Healthy	75	Remote Trip6
37	Circuit Breaker Fault Protection	76	Blocking Relay
38	Broken Conductor Trip		
39	Auto Re-closer Close		

(Table-18)

DI Assignment Setting

S.No.	Parameters	S.No.	Parameters
1	Circuit Breaker Close	24	Under voltage HiSet Blocking
2	Circuit Breaker Open	25	Over Voltage Blocking
3	Circuit Breaker Ready	26	Over Voltage HiSet Blocking
4	Remote Trip1	27	Zero Phase Sequence Voltage Blocking
5	Remote Trip2	28	Positive Phase Sequence Voltage Blocking
6	Remote Trip3	29	Negative Phase Sequence Voltage Blocking
7	Remote Trip4	30	Thermal Blocking
8	Remote Trip5	31	Broken Conductor Blocking
9	Remote Trip6	32	Cold Load Pickup Blocking
10	Group Toggling	33	Auto Recloser Blocking
11	Remote Reset	34	Synchro check Blocking
12	Oscilloscope Record Triggering	35	Over frequency protection Blocking
13	Cold Load	36	Over frequency Hiset protection Blocking
14	OverCurrent Blocking	37	Under frequency protection Blocking
15	ShortCircuit Stage1 Blocking	38	Under frequency Hiset protection Blocking
16	ShortCircuit Stage2 Blocking	39	Rate of change in freq Stage1 Blocking
17	Earth Blocking	40	Rate of change in freq Stage2 Blocking
18	Earth HiSet Blocking	41	Under Power Protection Blocking
19	UnderCurrent Blocking	42	Under Power Hiset Protection Blocking
20	Derived Earth Stage1 Blocking	43	Over Power Protection Blocking
21	Derived Earth Stage2 Blocking	44	Over Power Hiset Protection Blocking
22	Negative Phase Sequence Current Blocking	45	Reverse Power Protection Blocking
23	Under Voltage Blocking	46	Reverse Power Hiset Protection Blocking

(Table-19)

Function Reset Setting

S.No.	Parameters	S.No.	Parameters
1	OverCurrent Pickup	37	Broken Conductor Trip
2	OverCurrent Trip	38	Auto Recloser Close
3	ShortCircuit Stage1 Pickup	39	Synchro check
4	ShortCircuit Stage1 Trip	40	Over Frequency Pickup
5	ShortCircuit Stage2 Pickup	41	Over Frequency Trip
6	ShortCircuit Stage2 Trip	42	Over Frequency Hiset Pickup
7	Earth Pickup	43	Over Frequency Hiset Trip
8	Earth Trip	44	Under Frequency Pickup
9	Earth HiSet Pickup	45	Under Frequency Trip
10	Earth HiSet Trip	46	Under Frequency Hiset Pickup
11	UnderCurrent Pickup	47	Under Frequency Hiset Trip
12	UnderCurrent Trip	48	Rate of Change in Freq Stage1 Pickup
13	Derived Earth Stage1 Pickup	49	Rate of Change in Freq Stage1 Trip
14	Derived Earth Stage1 Trip	50	Rate of Change in Freq Stage2 Pickup
15	Derived Earth Stage2 Pickup	51	Rate of Change in Freq Stage2 Trip
16	Derived Earth Stage2 Trip	52	Under Power Pickup
17	Negative Phase Sequence current Pickup	53	Under Power Trip
18	Negative Phase Sequence current Trip	54	Under Power Hiset Pickup
19	UnderVoltage Pickup	55	Under Power Hiset Trip
20	UnderVoltage Trip	56	Over Power Pickup
21	UnderVoltage HiSet Pickup	57	Over Power Trip
22	UnderVoltage HiSet Trip	58	Over Power Hiset Pickup
23	OverVoltage Pickup	59	Over Power Hiset Trip
24	OverVoltage Trip	60	Reverse Power Pickup
25	OverVoltage HiSet Pickup	61	Reverse Power Trip
26	OverVoltage HiSet Trip	62	Reverse Power Hiset Pickup
27	Zero Phase Sequence Voltage Pickup	63	Reverse Power Hiset Trip
28	Zero Phase Sequence Voltage Trip	64	Remote Trip1
29	Positive Phase Sequence Voltage Pickup	65	Remote Trip2
30	Positive Phase Sequence Voltage Trip	66	Remote Trip3
31	Negative Phase Sequence Voltage Pickup	67	Remote Trip4
32	Negative Phase Sequence Voltage Trip	68	Remote Trip5
33	Thermal Relay	69	Remote Trip6
34	Thermal Alarm	69	Blocking relay
35	Trip Circuit Supervision		
36	Trip Circuit Supervision Helathy		

(Table-20)

LED Assignment Setting

S.No.	Parameters	S.No.	Parameters
1	OverCurrent Pickup	39	Auto Recloser Close
2	OverCurrent Trip	40	Auto Recloser Lockout
3	ShortCircuit Stage1 Pickup	41	Synchro check
4	ShortCircuit Stage1 Trip	42	Circuit Breaker Open
5	ShortCircuit Stage2 Pickup	43	Circuit Breaker Close
6	ShortCircuit Stage2 Trip	44	Over Frequency Pickup
7	Earth Pickup	45	Over Frequency Trip
8	Earth Trip	46	Over Frequency Hiset Pickup
9	Earth HiSet Pickup	47	Over Frequency Hiset Trip
10	Earth HiSet Trip	48	Under Frequency Pickup
11	UnderCurrent Pickup	49	Under Frequency Trip
12	UnderCurrent Trip	50	Under Frequency Hiset Pickup
13	Derived Earth Stage1 Pickup	51	Under Frequency Hiset Trip
14	Derived Earth Stage1 Trip	52	Rate of Change in Freq Stage1 Pickup
15	Derived Earth Stage2 Pickup	53	Rate of Change in Freq Stage1 Trip
16	Derived Earth Stage2 Trip	54	Rate of Change in Freq Stage2 Pickup
17	Negative Phase Sequence current Pickup	55	Rate of Change in Freq Stage2 Trip
18	Negative Phase Sequence current Trip	56	Under Power Pickup
19	UnderVoltage Pickup	57	Under Power Trip
20	UnderVoltage Trip	58	Under Power Hiset Pickup
21	UnderVoltage HiSet Pickup	59	Under Power Hiset Trip
22	UnderVoltage HiSet Trip	60	Over Power Pickup
23	OverVoltage Pickup	61	Over Power Trip
24	OverVoltage Trip	62	Over Power Hiset Pickup
25	OverVoltage HiSet Pickup	63	Over Power Hiset Trip
26	OverVoltage HiSet Trip	64	Reverse Power Pickup
27	Zero Phase Sequence Voltage Pickup	65	Reverse Power Trip
28	Zero Phase Sequence Voltage Trip	66	Reverse Power Hiset Pickup
29	Positive Phase Sequence Voltage Pickup	67	Reverse Power Hiset Trip
30	Positive Phase Sequence Voltage Trip	68	VTS Alarm
31	Negative Phase Sequence Voltage Pickup	69	CTS Alarm
32	Negative Phase Sequence Voltage Trip	70	Remote Trip1
33	Thermal Relay	71	Remote Trip2
34	Thermal Alarm	72	Remote Trip3
35	Trip Circuit Supervision	73	Remote Trip4
36	Trip Circuit Supervision Healthy	74	Remote Trip5
37	Circuit Breaker Fault Protection	75	Remote Trip6
38	Broken Conductor Trip		

(Table-21)

Broken Conductor Protection

Parameters	Display	Setting Range		Step Size	Default Setting
		Min	Max		
NPS to PPS Ratio	I2/I1 Ratio	0.10	0.50	0.01	Disable
Definite Time for broken conductor fault	(BC)Def Time	0.05sec	20.00sec	0.01sec	0.10sec

(Table-22)

Auto Recloser

Parameters	Display	Setting Range		Step Size	Default Setting
		Min	Max		
Auto-recloser	ENABLE	NO	YES	-	NO
Set Dead Time-1	D1	000.20sec	300.00sec	000.01sec	000.20sec
Set Dead Time-2	D2	000.2sec	300.00sec	000.01sec	000.20sec
Set Dead Time-3	D3	000.2sec	300.00sec	000.01sec	000.20sec
Set Dead Time-4	D4	000.2sec	300.00sec	000.01sec	000.20sec
Set Reclaim Time	t _R	000.2sec	300.00sec	000.01sec	000.20sec
Cycle I>	I> Cycle	2	4/Disable	1	2
Cycle I>>	I>> Cycle	2	4/Disable	1	2
Cycle I>>>	I>>> Cycle	2	4/Disable	1	2
Cycle Ie>	Ie> Cycle	2	4/Disable	1	2
Cycle Ie>>	Ie>> Cycle	2	4/Disable	1	2
Trip sense time	t _{TripSns}	0.05sec	2.00sec	0.01sec	0.05sec

(Table-23)

Thermal Over-load

Parameters	Display	Setting Range		Step Size	Default Setting
		Min	Max		
Thermal memory mode	TH_Mode	M1	M2/M3	-	M1
Permissible basic current	I _b	0.20xI _p	4.00xI _p	0.02xI _p	Disable
Constant	TH_Const	0.50	2.00	0.01	1.00
Heating time constant	TH_Heat	000.5min	180.0min	000.1min	000.5min
Cooling constant	TH_Cold	1.00xTh	8.00xTh	0.01xTh	1.00xTh
Thermal alarm	Alarm_R	20%	99%	1%	20%
NPS weighting factor	I2_Wght	0.05	2.50	0.05	2.50
Thermal reset	TH_Reset	00%	99%	1%	70%
Thermal trip characteristics	TH_Char	Th1	Th2	-	Th1

(Table-24)

Voltage Control Over-current

Parameters	Display	Setting Range		Step Size	Default Setting
		Min	Max		
Voltage control over current type	VCTO Type	MODE1	MODE2	-	MODE1
Control volt	Control Volt	20 %Un	100 %Un	1 %Un	20 %Un
Block over-current Stage-1	Block I>	NO	YES	-	YES
Over current pickup Stage-1	I> Pickup	0.20xIp	4.00xIp	0.01xIp	0.20xIp
Block over-current Stage-2	Block I>>	NO	YES	-	YES
Over current pickup Stage-2	I>> Pickup	0.20xIp	4.00xIp	0.01xIp	0.20xIp
Block short circuit Stage-1 current	Block I>>>	NO	YES	-	YES
Short circuit Stage-1 current	I>>> Pickup	0.50xIp	30.00xIp	0.50xIp	0.50xIp

(Table-25)

Erase Counter Record

Parameters	Display	Setting Range		Step Size	Default Setting
		Min	Max		
Trip Count	Trip Counter	NO	YES	-	NO
Thermal Memory Reset	Thermal m/m Reset	NO	YES	-	NO
Erase Events	Events Erase	NO	YES	-	NO
Erase Faults	Faults Erase	NO	YES	-	NO
Oscillator Record Erase	Osc. Record Erase	NO	YES	-	NO
Energy Counter Erase	EnergyCounterRst	NO	YES	-	NO

(Table-26)

Common Setting

These are the settings common for all the protections:

Parameters	Display	Setting Range		Step Size	Default Setting
		Min	Max		
Phase Rated Current	Ip	1.00Amp	5.00Amp	-	1.00Amp
Earth Rated Current	In	1.00Amp	5.00Amp	-	1.00Amp
Phase CT Ratio	Ph CTRatio	001	9999	1	001
Earth CT Ratio	E CTRatio	001	9999	1	001
PT Ratio	PT Ratio	001	6500.0	0.1	001
Phase Selection	PHASE	SINGLE	THREE	-	SINGLE
Wire Configuration	WireConfig	STAR	DELTA	-	STAR
Nominal Frequency	FREQ (Fn)	50Hz	60Hz	10Hz	50Hz
Phase Rotation	Ph Rotation	1-2-3	1-3-2	-	1-2-3
Fault Message Status	[F]Status	Disable	Enable	-	Disable
Service Mode	Servc Mode	Disable	Enable	-	Disable

(Table-27)

Voltage Transformer Supervision Setting (VTS)

Parameters	Display	Setting Range		Step size	Default Setting
		Min	Max		
VT Supervision Function	VTS Function	Disable	Enable	-	Disable
VT Supervision time delay	t_VTS	000.02sec	100.00sec	000.01sec	001.00sec

(Table-28)

Current Transformer Supervision Setting (CTS)

Parameters	Display	Setting Range		Step size	Default Setting
		Min	Max		
CT Supervision Function	CTS Function	Disable	Enable	-	Disable
Zero sequence current threshold	I0> Pickup	0.08xIn	1.00xIn	0.01xIn	1.00xIn
Zero sequence voltage threshold	U0< Pickup	2 %Un	100 %Un	1 %Un	10 %Un
CT Supervision time delay	t_CTS	000.02sec	100sec	0.01sec	000.10sec

(Table-29)

Disturbance Record

These are the settings for Oscilloscope recording:

Parameters	Display	Setting Range		Step Size	Default Setting
		Min	Max		
Oscilloscope recording selection	OSC. RECORD	NO	YES	-	NO
Pre-fault cycle	PRE CYCLE	002C	298C	1C	002C
Post-fault cycle	POST CYCLE	002C	298C	1C	002C
Triggering mode	TRIGGER MODE	PK-UP	PK-UP/TRIP/DI/ Anyone	-	PK-UP

(Table-30)

Communication

RS-485 Communication		Default Setting
Baud rate selection (programmable)	9600 / 19200 / 38400 / 57600 bps	9600 bps
Parity selection (programmable)	EVEN / ODD / NONE	NONE
Stop bit	1 Bit	1 Bit
Data bit	8 Bit data	8 Bit data
Remote address (programmable)	247/254	1
Cable required for Interface	Two wire twisted shielded cable	-----

* For MODBUS : Remote Address Setting Range is 1 - 247
& For IEC 103 : Remote Address Setting Range is 1 - 254

(Table-31)

Front USB Communication	
Protocol	CSE Proprietary Protocol: available with front software
Baud rate	115200 bps
Cable required for Interface	USB cable type (A to A)

(Table-32)

15.0 Technical Data

Measuring Input

Rated Data	Rated current I_n : 1A or 5A
	Rated frequency F_n : 50 Hz/60Hz
Drop out to Pickup Ratio	>96%
Reset Time	30mSec
AC Current	At $I_n=1A$: <0.1 VA
VA Burden	: At $I_n=5A$ <0.2 VA
AC Voltage, VA Burden	At $V_n=110V$: <0.06 VA
Thermal withstand capability in current circuit	Dynamic current withstand
	for 1 Sec : 100 x I_n
	for 10 Sec : 30 x I_n
	continuously : 4 x I_n

(Table-33)

Trip Time Accuracy for Current Protections

Parameters	Accuracy
Trip time accuracy for protections except NPS & REF	$\pm 30mSec$ OR $\pm 5\%$ (whichever is higher)
Trip time accuracy for NPS	$\pm 60mSec$ OR $\pm 7.5\%$ (whichever is higher)
Trip time accuracy for REF	Corresponding to error generated by inaccuracies in each phase $\pm 30mSec$ OR $\pm 5\%$ (whichever is higher)

(Table-34)

Trip Time Accuracy for Voltage Protections

Parameters	Accuracy
Trip time accuracy for voltage protections	Inaccuracy in Trip Timing in reference to $\pm 2\%$ error in measured voltage OR $\pm 30mSec$

(Table-35)

Measurement Accuracy

Parameters	Range	Frequency Range	Accuracy
Current in Ampere	1.0-30x I_n	50-60Hz	Less than $\pm 2\%$
Voltage	5-150% U_n	50-60Hz	Less than $\pm 2\%$
Power	--	--	Less than $\pm 5\%$
Power Factor	--	--	Less than ± 0.02
Frequency	$F_n \pm 10$ Hz	40-70 Hz	Less than ± 0.01 Hz

(Table-36)

Trip Contact Rating

Contact rating	
Contact relay	Dry contact Ag Ni
Make current	Max. 30A & carry for 3S
Carry capacity	8A continuous
Rated voltage	250V AC / 30V DC
DC Current Carrying Capacity	8A@30VDC / 0.3A@110VDC/ 0.2A@220VDC
Breaking characteristics	
Breaking capacity AC	1500VA resistive
	1500VA inductive (PF=0.5)
	220V AC, 5A(cos ϕ =0.6)
Breaking capacity DC	135V DC, 0.3A (L/R=30ms)
	250V DC, 50W resistive or
	25W inductive (L/R=40ms)
Operation time	<10ms
Durability	
Loaded contact	10,000 operation minimum
Unloaded contact	30,000 operation minimum

(Table-37)

Auxiliary Supply

Rated auxiliary voltage UH	For L Model	18V-150V DC
	For H Model	80V-280V AC / 90V-300V DC
	For U Model	40V-280V AC / 18V-300V DC
Rated supply for digital input	Normal Voltage UN	40V-280V AC (Active)
	For H Model	40V-300V DC (Active)
		<25V AC (Inactive)
		<25V DC (Inactive)
	Normal Voltage UN	18V - 150V DC (Active)
	For L Model	<10V DC (Inactive)
Normal Voltage UN	>22V DC onwards	
	For U Model	>50V AC onwards
Power consumption	Quiescent approx. 3W	Operating approx. <7W

(Table-38)

Common Data

Dropout ratio	> 96%
Relay reset time	30 ms
Minimum operating time	30 ms
Transient overreach at instantaneous operation	$\leq 5\%$

(Table-39)

Date & Time Setting

Parameters	Display	Setting Range		Step Size	Default Setting
		Min	Max		
Date	DATE	1	31	1	---
Month	MONTH	Jan	Dec	1	---
Year	YEAR(2000 Y)	00	99	1	---
Day	DAY	SUN	SAT	1	---
Hour	HOUR	0	23	1	---
Minute	MIN	0	59	1	---
Second	SEC	0	59	1	---

(Table-40)

16.0 Standards

Type Test

F1	Functional Tests	Internal Design	Performance in line with Specification & Standards
		Specifications & IEC60255-6 IEC60255-3	Pickup/Drop down/ Power consumption in Current/Voltage/Aux Supply/ Trip timing accuracy: OC/ Directional/ NPS/ Thermal / OV/ Zero Seq/ Over Power/ freq/ Rate of change of Freq

Climatic Test

C1	Temperature Dry Cold (Relay operational)	IEC60068-2-1	-20 deg C, 96 hours
C2	Temperature Dry Cold Transportation & Storage	IEC60068-2-1	-25 deg C, 96 hours
C3	Temperature Dry Heat (Relay operational)	IEC60068-2-2	55 deg C, 96 hours
C4	Temperature Dry Heat Transportation & Storage	IEC60068-2-2	70 deg C, 96 hours
C5	Damp Heat Test (Relay operational)	IEC60068-2-3	95% @ +55 / +25 deg C, 6 cycle (12hr + 12hr each)

Enclosure

C6	Enclosure	IEC529	Front IP54 (Dust5x + Water x4)
----	-----------	--------	--------------------------------

Mechanical Test

Relay Operational

M1	Vibration response / Endurance test	IEC60255-21-1	Class I Vibration response (Relay operational) 10Hz~150 Hz - peak displacement 0.035 mm below 58/60 Hz, 0.5 g above, 1 sweep cycle in each axis Vibration endurance (Relay de-energised) 10 Hz~150 Hz 1g, 20 sweep cycles in each axis
M2	Shock Response / Withstand Test	IEC60255-21-1	Class I Shock response (Relay operational) 5g 11mS 3 pulse in each axis Shock withstand (Relay de-energised) 15g 11mS 3 pulses in each axis
M3	BUMP	IEC60255-21-1	Bump (Relay de-energised) 10g 16mS 1000 pulses in each axis
M4	Seismic	IEC60255-21-3	Class I Method A single axis sine sweep 1 Hz~35 Hz~below 8/9 Hz 3.5 mm peak displacement horizontal axis, 1.5 mm vertical axis above 8/9 Hz 1g horizontal, 0.5 g vertical 1 sweep cycle in each axis

Electrical Test			
E1	Insulation Resistance >100MΩ	IEC60255-5	500V DC, 5 sec between all terminals & case earth, between terminals of independent circuits including contact circuits and across open contacts
E2	DC & AC Supply Voltage (Relay operational)		IEC60255-6 Voltage range, upper & lower limit continuous withstand, ramp up & down over 1 minute
E3	Voltage Dips, Short Interruptions & Voltage variations immunity (Relay operational)	IEC 1000-4-11	IEC60255-113 Dips & 3 Interruptions at 10 sec intervals of duration between 10mS and 500mS at zero crossings & at other points on wave Variation: 100% to 40% over 2s, hold for 1s, return to 100% over 2s
E4	Ripple in DC supply (Relay operational)	IEC60255-11	12% AC ripple
E5	Dielectric Test (Relay de-energised) No breakdown or flash over Test voltage 45~65 Hz sinusoidal or with DC voltage at 1.4x the stated AC values	IEC60255-5	2.0 KV @ 1min All circuit to Earth / Between IP & OP except communication terminals
E6	High Voltage Impulse (Relay de-energised)	IEC60255-5	5 kV peak 1.2/50uS, 0.5 J-3 positive, 3 negative between all terminals to case earth between independent circuits
E7	VT Input Thermal Withstand		1.5xVn, continuous
E8	CT Input Thermal Withstand		250xIn half wave 100xIn for 1 second 30xIn for 10 second 4xIn continuously
E9	Contact performance & endurance tests	IEC60255-14,15 IEC60255-23	

Electro-magnetic Compatibility			
R1	Electrical fast Transient/Burst (Relay operational)	IEC60255-22-4 IEC60100-4-4	Class IV- ± 4.0 kV All Circuits. Pulse 5/50msec / Duration 15msec / Period: 300msec/ Pulse Freq: 5KHz / 2KV at I/O
R2	HF Disturbance Test (Oscillatory Waves) 1 MHZ Burst (Relay operational)	IEC60255-22-1	Class III Longitudinal 2.5 kV peak, 2sec between independent circuits & case earth
R3	Electrostatic Discharge (Relay operational)	IEC60255-22-2 IEC61000-4-2	Class III 8kV air discharge, 6KV contact No of Discharge : 10 both polarities at 1 sec intervals
R4	Conducted Disturbance RF fields (Relay operational)	IEC61000-4-6 IEC60255-22-6	0.15 to 80 MHZ (Level-3) Severity Level 10V RMS + sweeps 0.05-0.15 MHZ & 80-100 MHZ
R5	Radiated RF E-M field immunity test (Relay operational)	IEC60255-22-3 IEC61000-4-3	Class III Test method A + sweep 80-1000 MHZ or IEC 1000-4-3 80-1000 MHZ severity 10 V/m 80% modulated 1 kHz
R6	Surge Immunity capacitively coupled (Relay operational)	IEC61000-4-5 Class 5 Test level 4 IEC60255-22-5: 2008 Latest: IEC60255-26:2013	Short circuit combination wave generator 1.2 uS/50 uS open circuit repetition rate 1 per minute Power supply, CT & VT circuits – 4kV common mode 2 Ohm source 2kV differential mode 12 Ohm source
R7	Power Frequency Magnetic Field (Relay operational)	IEC61000-4-8	100 A/m for 1 minute in each of 3 axes
R8	Conducted & Radiated RF Interference Emission (Relay operational)	EN55011 IEC60255-25	CISPR11/ Class A
R9	Power Frequency, conducted common mode	IEC 1000-4-16 IEC60255-22-7	D.C. to 150 kHz Test Level 4 300V at 16 2/3 Hz and 50 Hz

17.0 Recommended Terminal Lugs Specifications

Term Blocks	Type/Cable Specifications
Current Inputs	Ring Type lug / 2.5mm ² or 4 mm ² control cable
Auxiliary Supply	Pin Type lug / 1.5 mm ² / 2.5 mm ² control cable
Rear Comm. Port	Pin Type lug / 1.5 mm ² / 2.5 mm ² control cable
Front Comm. Port	USB, Type - A to A
Binary Input	Pin Type lug / 1.5mm ² / 2.5mm ² control cable
Binary Output	Pin Type lug / 4.0mm ² control cable
Earth Connections	Ring Type / 2.5mm ² or 4 mm ² contact cable



USB Cable required for Front communication
(Type A to A)



18.0 Connection Diagram

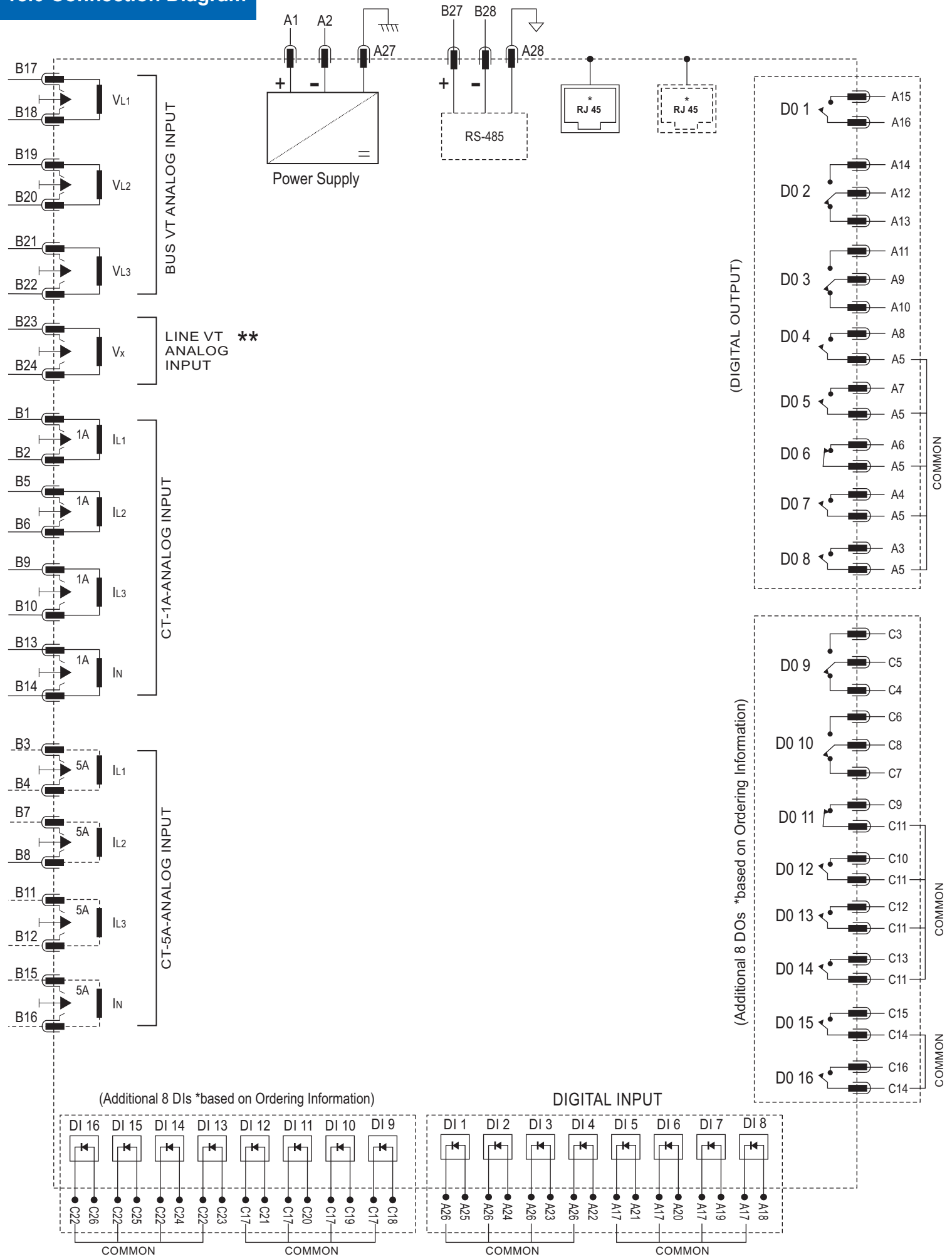

** Available only with CSEZEN F600

18.1 Terminal Description

Terminal No.	Terminal Description	Contact Details
A1	: Auxiliary Supply (+)	
A2	: Auxiliary Supply (-)	
A3-A5	: Digital Output-8 (DO-8)	: (NO-COMMON)
A4-A5	: Digital Output-7 (DO-7)	: (NO-COMMON)
A6-A5	: Digital Output-6 (DO-6)	: (NC-COMMON)
A7-A5	: Digital Output-5 (DO-5)	: (NO-COMMON)
A8-A5	: Digital Output-4 (DO-4)	: (NO-COMMON)
A11-A9-A10	: Digital Output-3 (DO-3)	: (NO-COMMON-NC)
A14-A12-A13	: Digital Output-2 (DO-2)	: (NO-COMMON-NC)
A15-A16	: Digital Output-1 (DO-1)	: (NO-COMMON)
A18-A17	: Digital Input-8 (DI-8)	
A19-A17	: Digital Input-7 (DI-7)	
A20-A17	: Digital Input-6 (DI-6)	
A21-A17	: Digital Input-5 (DI-5)	
A22-A26	: Digital Input-4 (DI-4)	
A23-A26	: Digital Input-3 (DI-3)	
A24-A26	: Digital Input-2 (DI-2)	
A25-A26	: Digital Input-1 (DI-1)	
B1-B2	: CT Terminal for Phase current (1A) input in L1 Phase	
B5-B6	: CT Terminal for Phase current (1A) input in L2 Phase	
B9-B10	: CT Terminal for Phase current (1A) input in L3 Phase	
B13-B14	: CT Terminal for Earth current input (1A)	
B3-B4	: CT Terminal for Phase current (5A) input in L1 Phase	
B7-B8	: CT Terminal for Phase current (5A) input in L2 Phase	
B11-B12	: CT Terminal for Phase current (5A) input in L3 Phase	
B15-B16	: CT Terminal for Earth current input (5A)	
B17-B18	: Bus VT Analog input in L1 Phase	
B19-B20	: Bus VT Analog input in L2 Phase	
B21-B22	: Bus VT Analog input in L3 Phase	
B23-B24	: Line VT Analog input **	
B27	: RS-485 MODBUS (+)	
B28	: RS-485 MODBUS (-)	
A28	: Ground (RS-485)	
A27	: Earth (Aux. Supply)	
C3-C5-C4	: Digital Output-9 (DO-9)	: (NO-COMMON-NC)
C6-C8-C7	: Digital Output-10 (DO-10)	: (NO-COMMON-NC)
C9-C11	: Digital Output-11 (DO-11)	: (NC-COMMON)
C10-C11	: Digital Output-12 (DO-12)	: (NO-COMMON)
C12-C11	: Digital Output-13 (DO-13)	: (NO-COMMON)
C13-C11	: Digital Output-14 (DO-14)	: (NO-COMMON)
C15-C14	: Digital Output-15 (DO-15)	: (NO-COMMON)
C16-C14	: Digital Output-16 (DO-16)	: (NO-COMMON)
C18-C17	: Digital Input-9 (DI-9)	
C19-C17	: Digital Input-10 (DI-10)	
C20-C17	: Digital Input-11 (DI-11)	
C21-C17	: Digital Input-12 (DI-12)	
C23-C22	: Digital Input-13 (DI-13)	
C24-C22	: Digital Input-14 (DI-14)	
C25-C22	: Digital Input-15 (DI-15)	
C26-C22	: Digital Input-16 (DI-16)	

18.2 VT Connection Diagram

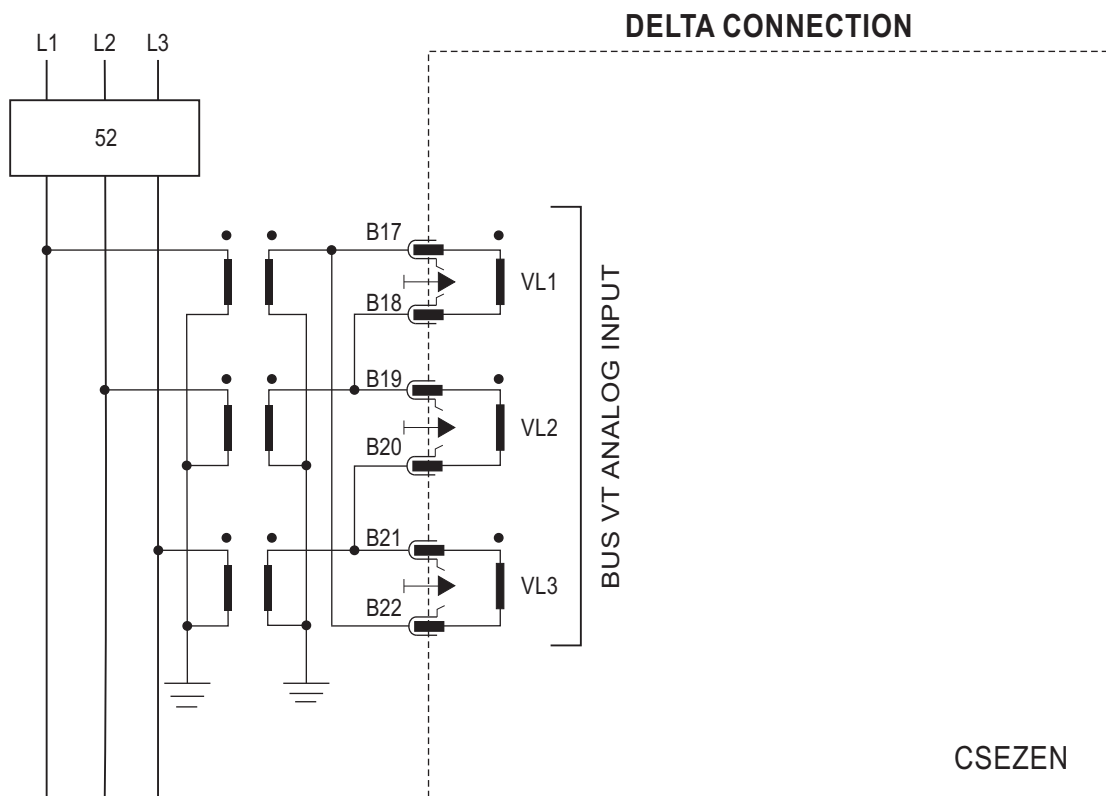
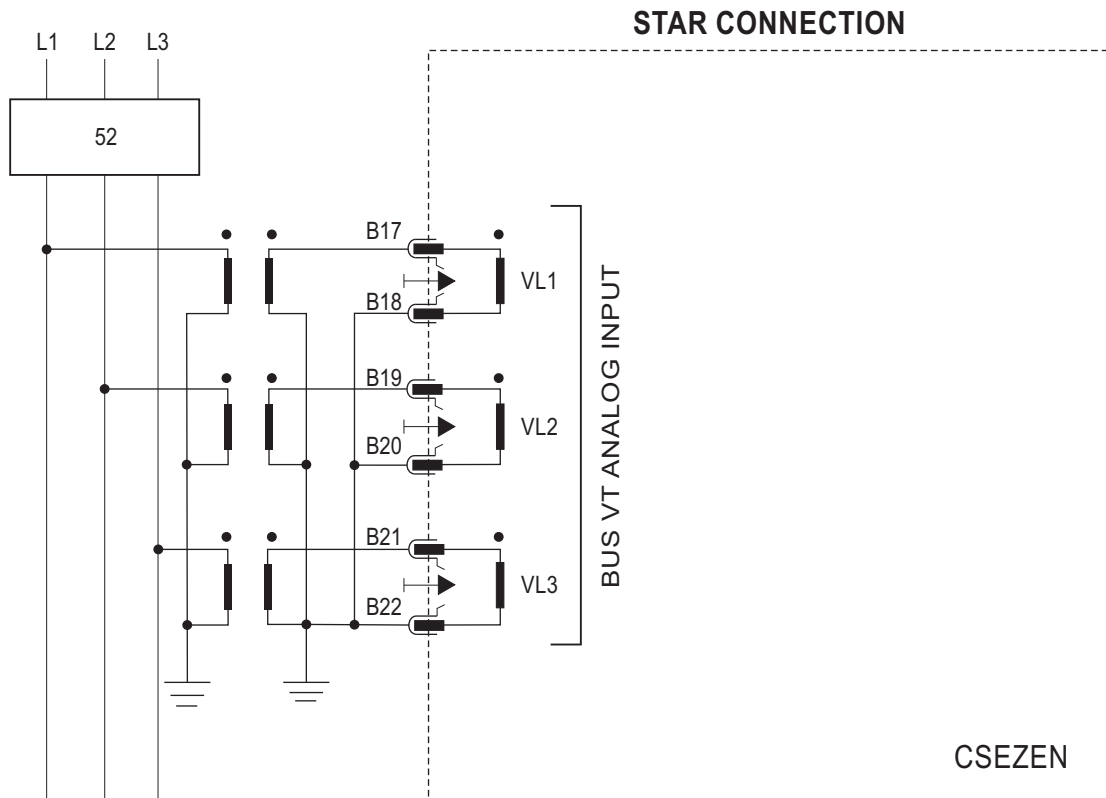

18.2A CT Connection Diagram

CT Schemes : Holmgreen Residual CTs Connection for 1A

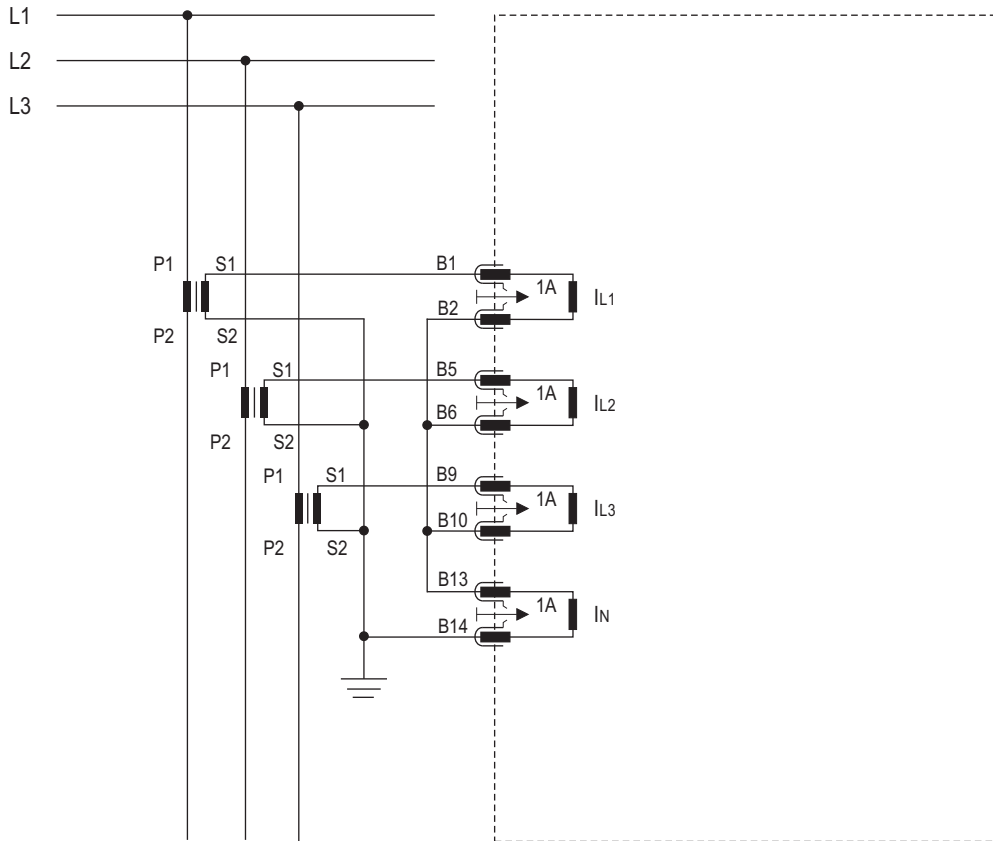

18.2B CT Connection Diagram

CT Schemes : Holmgreen Residual CTs Connection for 5A

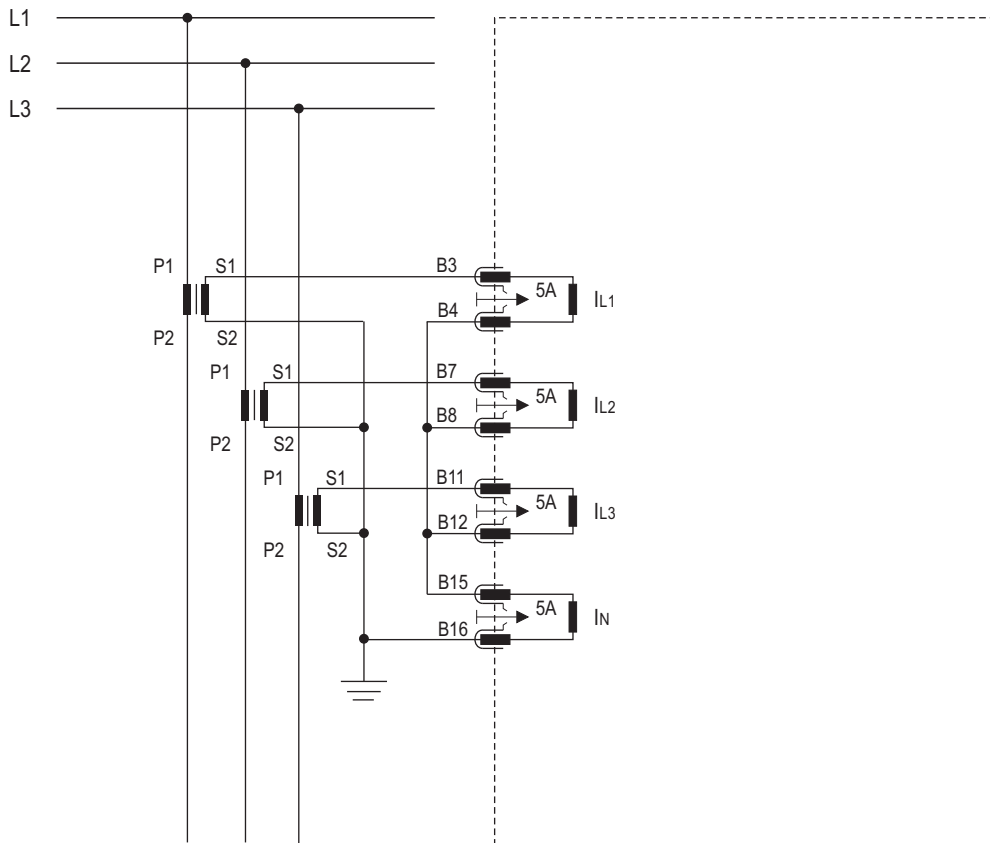

18.3 Connection Scheme for Restricted Earth

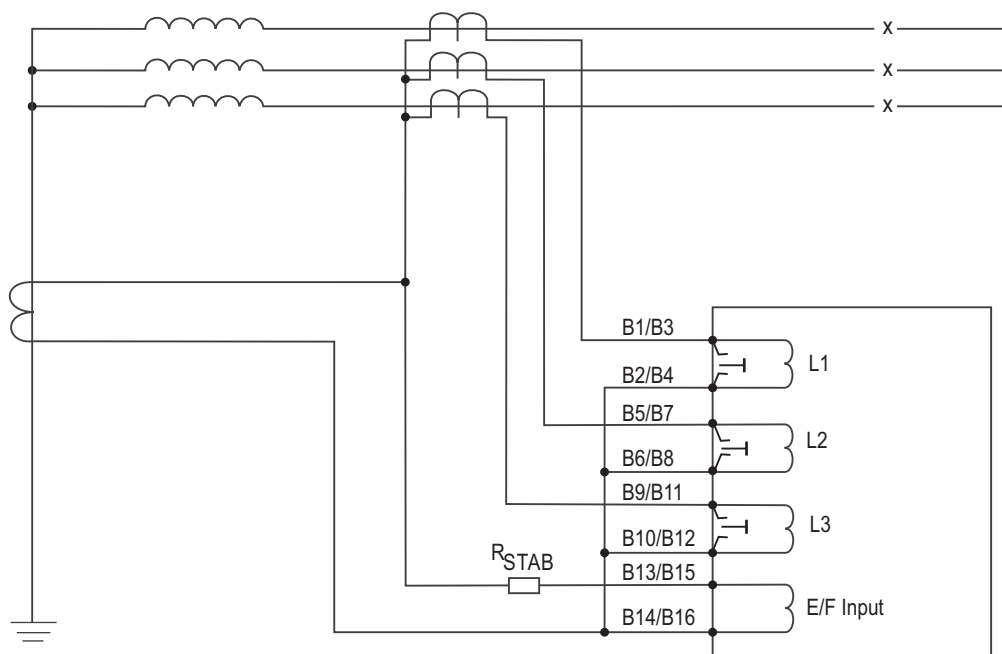

CT Connection Diagram for High Impedance REF Application

18.4 Trip Circuit Supervision Diagram

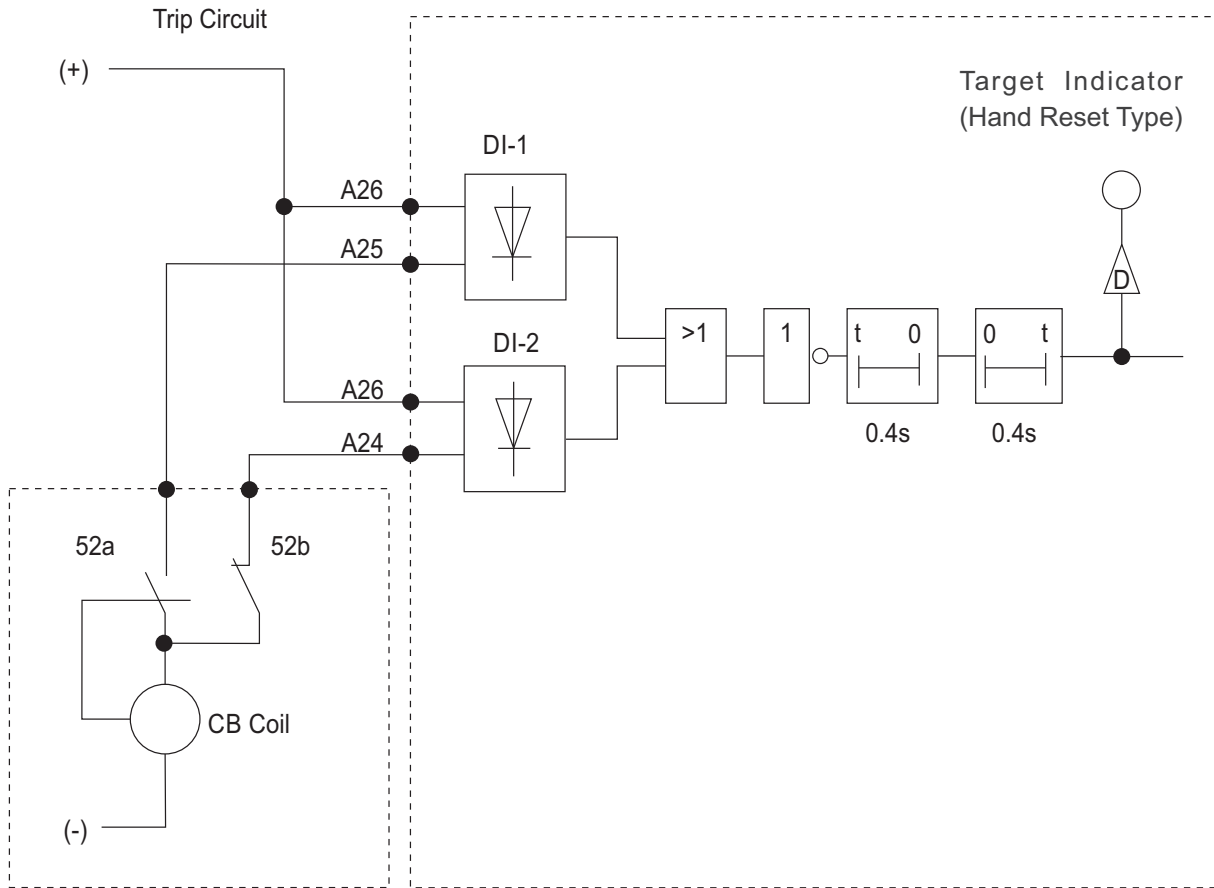

(Trip Circuit Supervision Function)

19.0 Dimensional Details

All the dim are in mm (Gen. Tol ± 1.0mm)

Front View

Top View

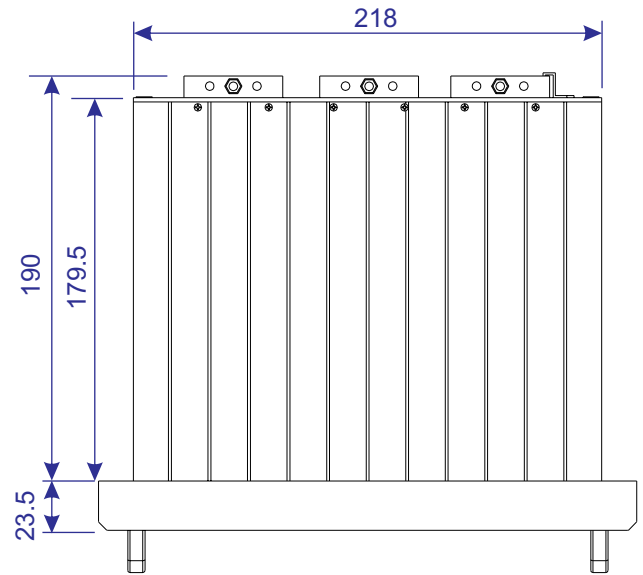
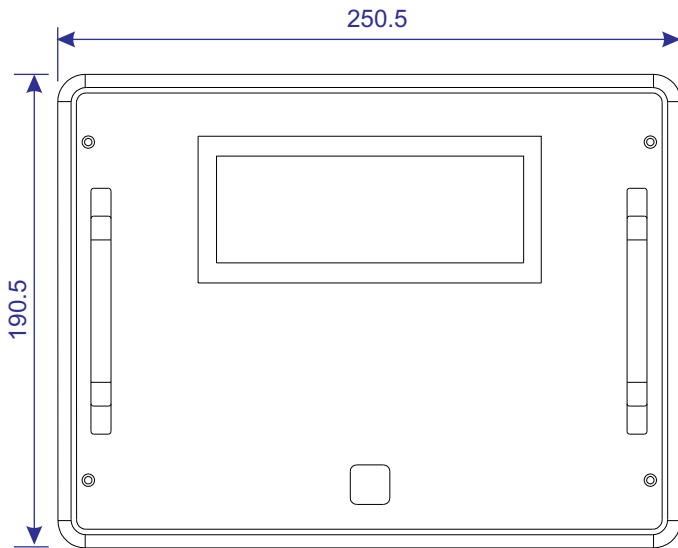

Side View

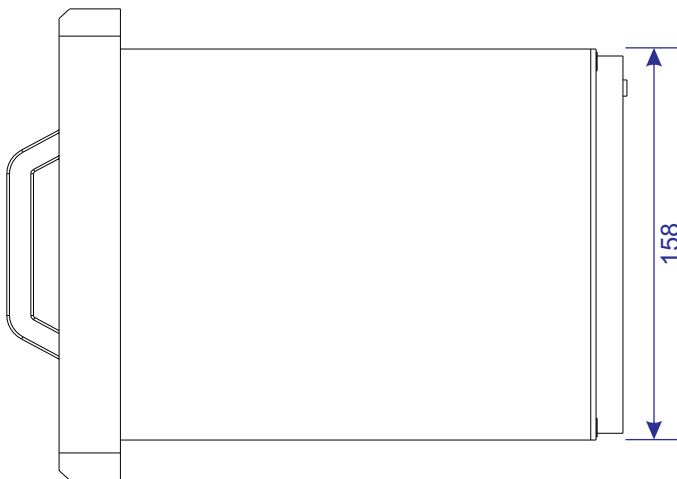

20.0 Panel mounting of the Relay

for Panel mounting

Screw	: M4x12mm
Qty	: 8 Nos.

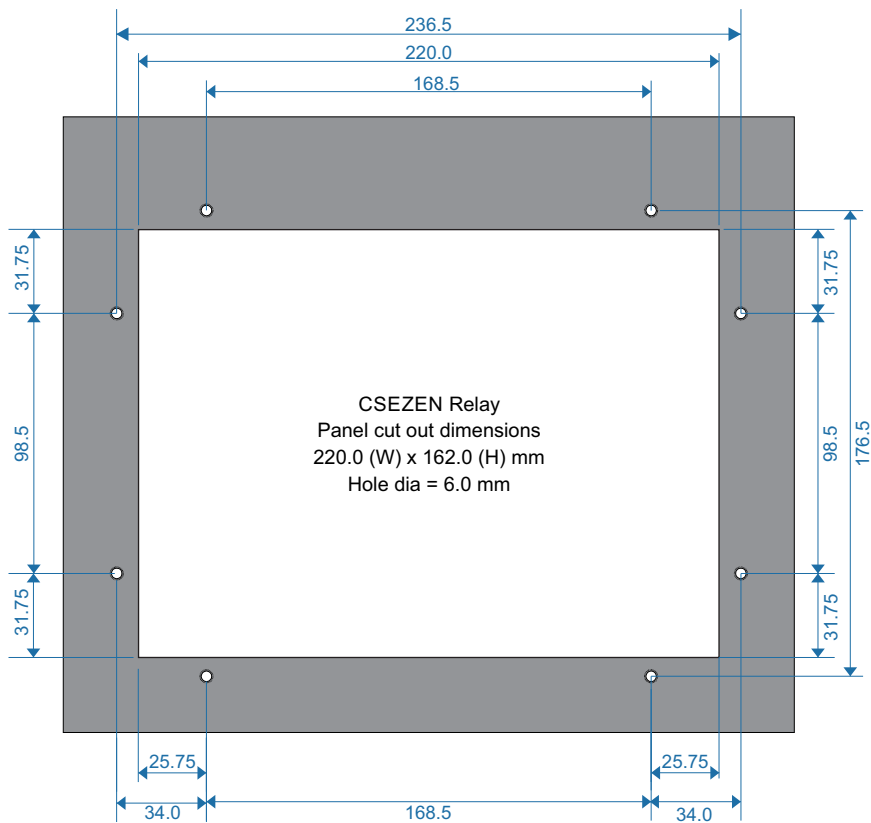
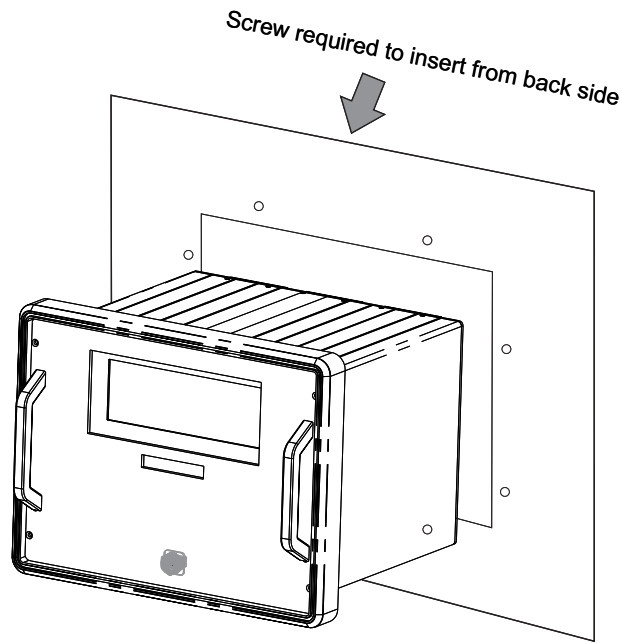

Pictorial view of Panel mounting of the Relay

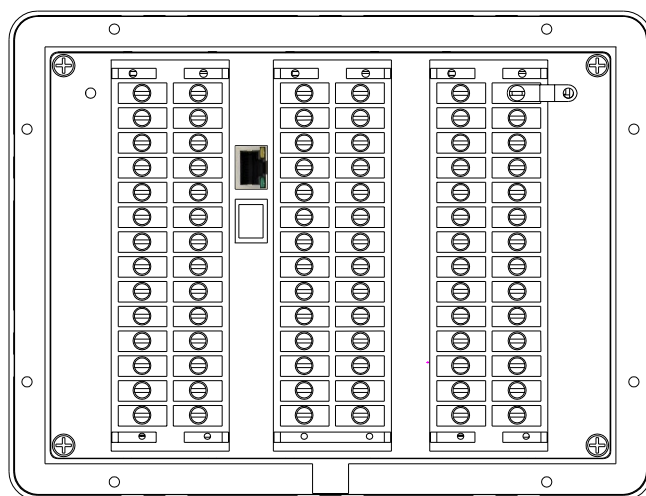
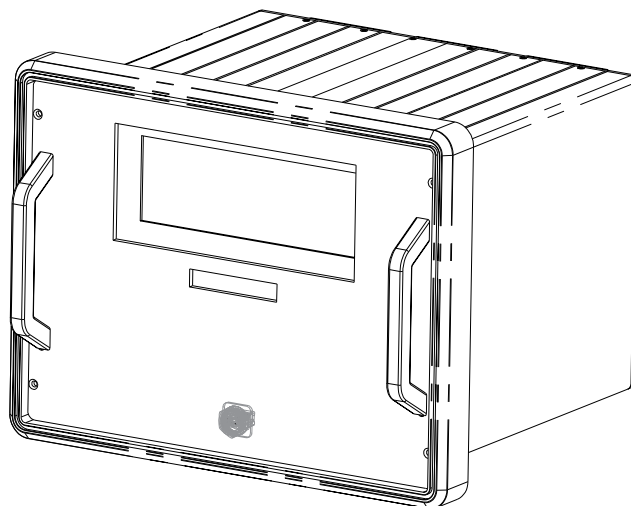

21.0 Ordering Information

CSEZEN - F - 600 - x - x - D - x - x - x - x - E - H

Voltage Input	
1	110V
4	400V

Earth Fault	
S	Sensitive Earth Fault
N	Non-Sensitive Earth Fault

Digital I O Card	
0	8 DI /DO
1	16 DI /DO

Auxiliary Supply	
L	18V-150V DC
H	80V-280V AC / 90V-300V DC
U	40V-280V AC / 18V-300V DC

COMMUNICATION PROTOCOL	
A	MODBUS on RS-485
B	IEC 60870-5-103 on RS-485
C	IEC 61850 Single RJ-45 port Ed-2
D	IEC 61850 PRP-Dual RJ-45 port Ed-2

Time Synchronisation	
0	None
S	SNTP on RJ-45



Issue Date : 10.08.17
Rev. No : 10
Rev. Date : 13.01.26



CSEZEN- E Catalogue



Technical Question or After-sales Service

*Customer Center Quick Response
Service, Excellent Technical Support*

1800 572 2012

NOTE

The content in this document are not binding and is for general information.
C&S reserves the right to change the design, content or specification contained in this, without prior notice.

