

CSEnEX-U200

● Intelligent Measuring and Protection Device

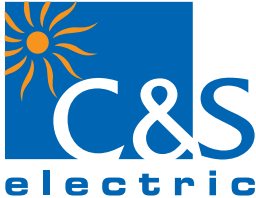

Catalog



PMD Division

CONTENT

S.No.	Description
1.	Introduction
2.	Application
3.	Protection Features
4.	Supervision Functions
5.	Hardware
6.	Functional Diagram
7.	Protection Functions
8.	Data Acquisition Functions
9.	Fault Record
10.	Event Record
11.	Human Machine Interface
12.	Communication (Local & Remote)
13.	Setting Ranges
14.	Technical Data
15.	Type Test
16.	Connection Diagram
17.	Dimension Details
18.	Ordering Information



1) Introduction

CSENEX-U Series relays provide reliable and high performance protection.

The CSENEX-U 200 is a relay for AC voltage supervision with universal application; it protects the three phase network against over, under voltage, unbalance or earth faults in isolated networks. Beside the pure RMS value measurement of the line voltage the CSENEX-U 200 can detect the phase sequence, voltage unbalance and earth faults.

- Draw out enclosure have modular design
- Measurement & Protection
- DO Matrix Programmability
- Intelligent key for DO status, details of fault pickup & status of last fault occurred
- Suitable for Star & Delta configuration
- CSENEX-U relays are equipped with self supervision function
- Last 10 fault record (non-volatile memory) with time stamp
- Last 50 event record (non-volatile memory) with time stamp
- SCADA Communication (Local & Remote)

2) Application

The CSENEX-U relay has been designed for controlling, protecting and monitoring industrial, utility distribution networks and substations. They can also be used as part of a protection scheme for feeders, transformers and generators.

3) Protection Features

- Under / Over Voltage
- Residual Voltage / Voltage Unbalance

4) Supervision Function

- Open-Close Breaker Command

5) Hardware

- Digital Signal Processor based numeric design
- Measures true RMS with DFT filter
- 4 Voltage Analog Input
- Max. 4 Digital Outputs
- 8 LEDs at Pickup & Trip on fault + 3 LEDs with special function of 3 control keys
- 16x4 Alpha numeric LCD
- 5 Push button on the front for HMI
- 3 Push button on the front for Control
- RS-485/USB ports for Communication

6) Functional Diagram

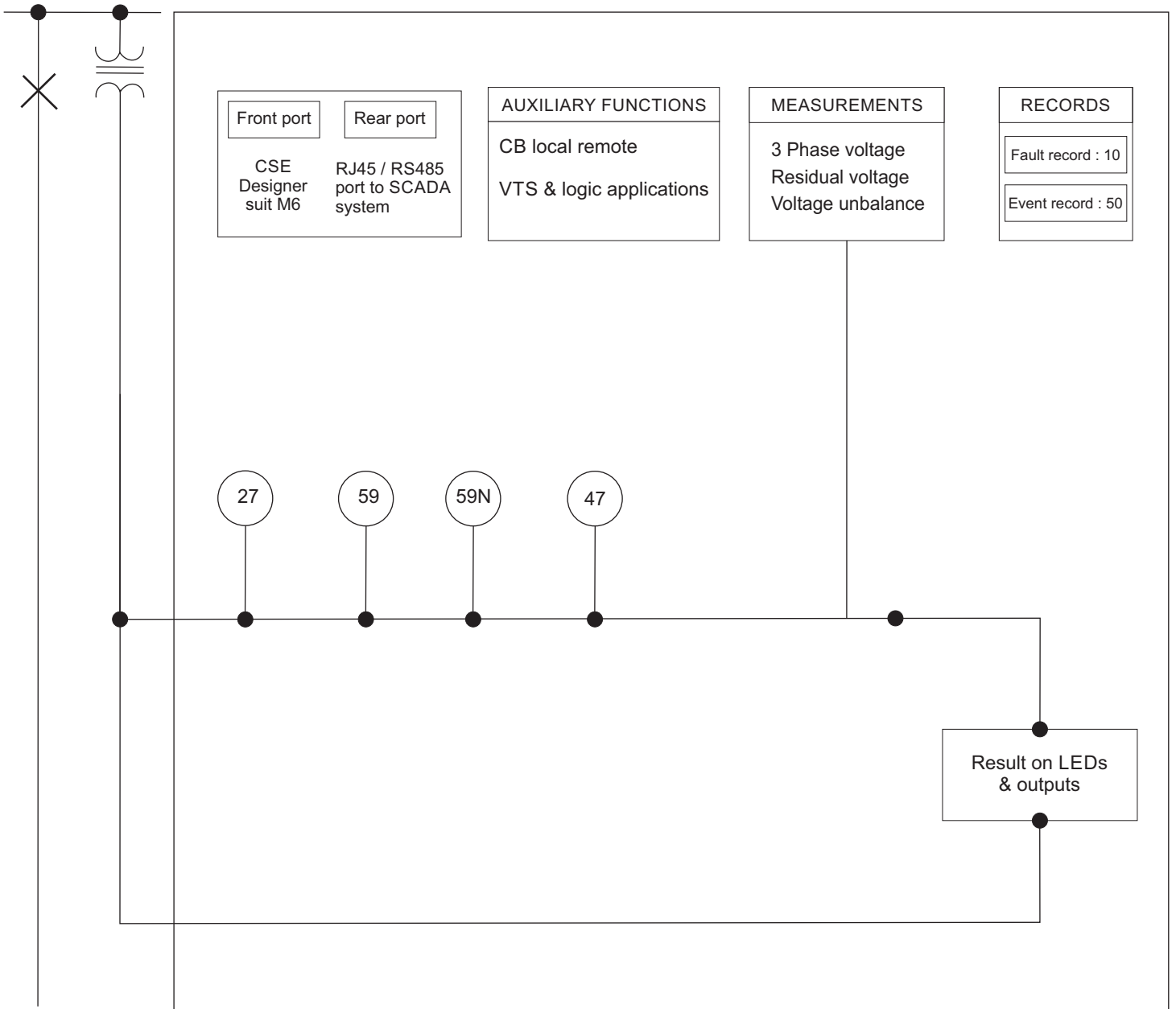

(Figure-2) CSENX-U Functional Diagram

7) Protection Functions

Voltage Protection

The relay is equipped with an independent over, 2 step over ($U>$, $U>>$) and under voltage supervision ($U<$, $U<<$) simultaneously with separately adjustable tripping values and delay times. Voltage measuring is 3-phase. In this process there is a continuous comparison of the line conductor voltages in case of a delta connection and of the phase voltages in case of a star connection with the preset limit Values.

a) Under / Over voltage

For under / over voltage protections settings.

Block on under voltage ($U_{lossBlk}$) in case of power failure is user selectable. If it is enable then for $<10\%$ of U_n (Power Failure) under voltage protections will be blocked. Protection Blocking is indicated by BLOCK Led.

b) Zero Sequence Over voltage (Neutral Displacement)

CSENEX-U relays will operate from the zero sequence over voltage functions according to the VT configuration

VT configuration=EXTERNAL, then the [59N] will operate based on the residual voltage measured on the relay terminals

VT configuration = INTERNAL, then [59N] will operate based on the zero sequence voltage

$\vec{U}_0 = 1/3 | (\vec{U}_{L1} + \vec{U}_{L2} + \vec{U}_{L3}) |$ calculated internally.

c) Negative Sequence over voltage

This function is based on the negative-sequence component of the voltage, which is calculated internally and displayed on the screen of the front panel: It is designed to detect any voltage unbalance condition.

$$\vec{U}_2 = 1/3 | (\vec{U}_{L1} + a^2 \vec{U}_{L2} + a \vec{U}_{L3}) |$$

d) Positive Sequence Under voltage

This function is based on the positive phase sequence component of the voltage, which is calculated internally.

$$\vec{U}_1 = 1/3 | (\vec{U}_{L1} + a \vec{U}_{L2} + a^2 \vec{U}_{L3}) |$$

e) CB Closing Delay

In order to protect instant closing of breaker after fault, A configurable timer called CB_CLOSE_DELAY is provided. One output contact can be configured for this protection and it can be put in series of closing mechanism to inhibit the CB Closing process till the timer remains active. This time can be configurable.

8) Data Acquisition Function

Measurement

- 3 Phase Star Voltage
- Residual Voltage
- 3 Phase Delta Voltage
- Negative / Positive Sequence Voltage

9) Fault Record

CSENEX-U records last 10 faults in its non volatile memory with its time stamp. Each record has the following information:

Fault Format		UL23	:	XX.XXV	
UL1	:	XX.XXV	UL31	:	XX.XXV
UL2	:	XX.XXV	HR MIN	:	HH:MIN
UL3	:	XX.XXV	SEC Ms	:	Sec: mSec
U0	:	XX.XXV	DATE	:	DD:MM:YR
UL12	:	XX.XXV	F-TYPE	:	Type of fault

Fault Recording

Faults

Date : 14 / 12 / 2012 Device Name : CSENEX-U200 Relay Version : 1.0.00.08

Time : 11 : 36 : 4

Sr.No.	Faults	UL1 (V)	UL2 (V)	UL3 (V)	U0 (V)	UL12 (V)	UL23 (V)	UL31
1	Overvoltage Hiset Fault in L1 Phase	59.79	60.13	59.26	0.00	103.66	104.24	102.6
2	Overvoltage Hiset Fault in L1 Phase	68.95	68.75	68.89	0.00	119.45	119.24	119.1
3	Overvoltage Fault in L1 Phase	68.90	68.94	69.16	0.00	119.19	119.62	119.8
4	Overvoltage Hiset Fault in L1 Phase	40.06	40.07	41.02	0.00	68.31	70.95	69.62
5	Overvoltage Fault in L1 Phase	40.07	40.08	39.62	0.00	69.50	68.05	69.58
6	Overvoltage Hiset Fault in L1 Phase	39.83	40.07	39.44	0.00	69.12	69.04	68.96
7	Overvoltage Fault in L1 Phase	39.97	40.27	39.51	0.00	69.00	68.65	69.70
8	Overvoltage Hiset Fault in L1 Phase	59.93	60.17	58.97	0.18	103.95	104.27	102.2
9	Overvoltage Fault in L1 Phase	59.88	60.15	59.48	0.00	103.70	103.73	103.4
10	Overvoltage Hiset Fault in L1 Phase	59.87	59.96	59.18	0.10	103.60	104.51	102.2

Refreshed..

(Figure-3) Fault Data recording on PC software

10) Event Record

The unit stores in non volatile memory the last 50 events with it's time stamp. When the available memory space is exhausted, the new event automatically overwrites the oldest event, which can be retrieved from a PC, with the following format:

EVENT : EVENT NUMBER
 HOUR : HH.MM
 SEC mSEC : SEC: mSEC
 DATE : DD/MM/YY

The user can view event records via the front USB interface software

- Description of event number available in event list or in front end software.

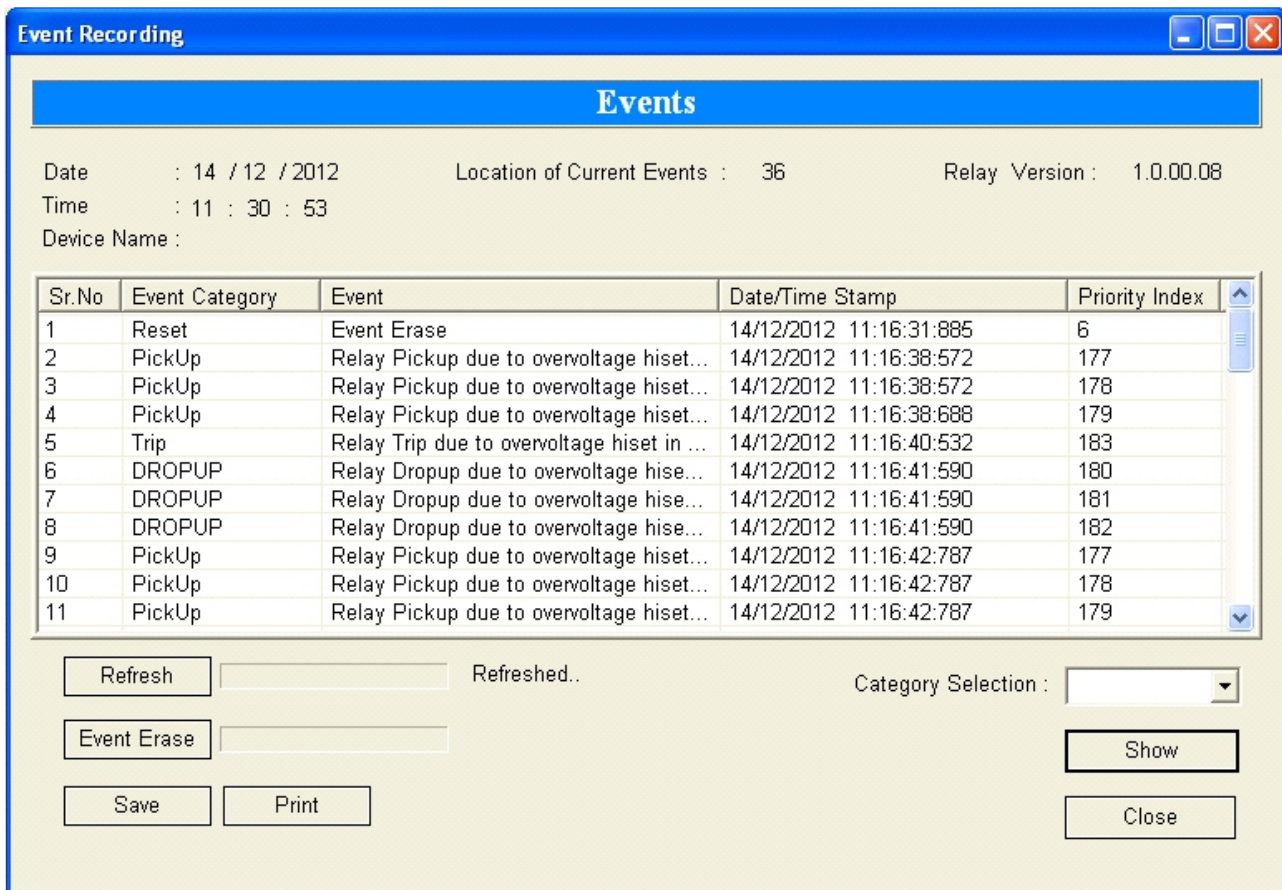

The screenshot shows a software window titled "Event Recording" with a sub-header "Events". It displays the following information:

- Date : 14 / 12 / 2012
- Location of Current Events : 36
- Relay Version : 1.0.00.08
- Time : 11 : 30 : 53
- Device Name :

Sr.No	Event Category	Event	Date/Time Stamp	Priority Index
1	Reset	Event Erase	14/12/2012 11:16:31:885	6
2	PickUp	Relay Pickup due to overvoltage hiset...	14/12/2012 11:16:38:572	177
3	PickUp	Relay Pickup due to overvoltage hiset...	14/12/2012 11:16:38:572	178
4	PickUp	Relay Pickup due to overvoltage hiset...	14/12/2012 11:16:38:688	179
5	Trip	Relay Trip due to overvoltage hiset in ...	14/12/2012 11:16:40:532	183
6	DROPUP	Relay Dropup due to overvoltage hise...	14/12/2012 11:16:41:590	180
7	DROPUP	Relay Dropup due to overvoltage hise...	14/12/2012 11:16:41:590	181
8	DROPUP	Relay Dropup due to overvoltage hise...	14/12/2012 11:16:41:590	182
9	PickUp	Relay Pickup due to overvoltage hiset...	14/12/2012 11:16:42:787	177
10	PickUp	Relay Pickup due to overvoltage hiset...	14/12/2012 11:16:42:787	178
11	PickUp	Relay Pickup due to overvoltage hiset...	14/12/2012 11:16:42:787	179

Below the table, there are several control buttons and fields:

- Refresh button with an input field and "Refreshed.." label.
- Event Erase button with an input field.
- Save and Print buttons.
- Category Selection dropdown menu.
- Show and Close buttons.

(Figure-4) Event Data recording on PC Software







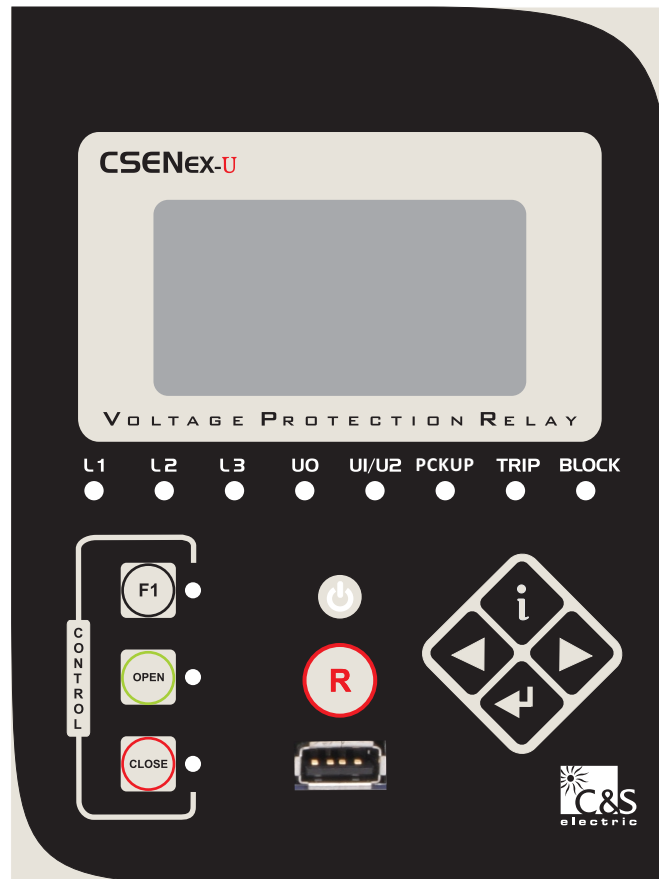

11) Human Machine Interface

It comprises of bright LCD display

- ◆ Four push switches for setting values of normal tripping characteristics and other operations for local access.
- ◆ One RESET push switch.
- ◆ One push switch for the functions assigned in the HMI to F1 key, 2 push switch to open or close circuit breaker
- ◆ Eight LEDs for pickup or tripping on fault and event in any phase.



(Figure-5)

Keys	Manual Key
	is used as intelligent key to see the details of last fault and Relay status.
	is used as a ENTER key.
	is used to manual reset (after pressing for 2 sec).
	is used to scroll in backward direction.
	is used to scroll in forward direction.
	To perform the assigned task either DO trip or Relay reset.
	To open the circuit breaker.
	To close the circuit breaker.

Output Contacts

No. of digital outputs	:	4 (DO1, DO2, DO3, DO4) 2 Change over (DO1, DO2), 2 Normal open (DO3, DO4)
Type of outputs	:	Relay
Programmable (DO Assignment)	:	Yes
Relay reset type	:	Programmable (Auto/Manual)

12) Communication (Local and Remote)

The unit has:

- 1 Front USB port for direct connection to a PC
- 1 Rear RS-485 communication port

a) Rear Communication

The protocol for the rear port is MODBUS-RTU.

b) Front Communication

The entire setting, Fault & Event are available on 'A' type USB (female) interface with CSE LIVELINK with saving & printing option. This unit also has Front-end Live Link simulation support for testing of relay even without any three phase injection source.

13) Setting Ranges

Active Group Setting

Parameters	Display	Setting Range		Step Size	Default Setting
		Min	Max		
Active Group	ACTIVE	Group1	Group2	1	Group1

(Table-1)

(1) Refer following formula for IDMT characteristics for over/under voltage

$$\text{Very Inverse} \quad t = \frac{\text{TMS}}{(V/V_s) - 1}$$

Where

- t = Operating time in seconds
- TMS = Time multiplier setting
- V = Applied Input Voltage
- V_s = Relay Setting Voltage

Note: This equation is only valid for V/V_s ratio < than 0.95 (under voltage) or ratio > 1.1 (over voltage)

Under Voltage / Over Voltage Setting

Parameters	Display	Setting Range		Step Size	Default Setting
		Min	Max		
Under voltage characteristics	U<char	DEFT	IDMT		DEFT
Blocking on loss of voltage	UlossBlk	Enable	Disable		Disable
Under voltage threshold setting	UV-THRE	5%Un	100%Un	1%Un	10%Un
Under voltage pickup setting	U<Pkup	5%Un	120%Un	1%Un	Disable
Under voltage TMS setting	U<Ti	0.05	2	0.01	0.05
Under voltage definite time	U<Td	0.03 sec	20.00 sec	0.01 sec	0.03 sec
Under voltage hi-set pickup setting	U<<Pkup	5%Un	120%Un	1Un	Disable
Under voltage definite time	U<<Td	0.03 sec	20.00 sec	0.01 sec	0.05 sec
Over voltage characteristics	U>char	DEFT	IDMT		DEFT
Over voltage pickup setting	U>Pkup	20%Un	170%Un	1%Un	Disable
Over voltage TMS setting	U>Ti	0.05	2	0.01	0.05
Over voltage definite time	U>Td	0.03 sec	20.00 sec	0.01 sec	0.05 sec
Over voltage hi-set pickup setting	U>>Pkup	20%Un	170%Un	1%Un	Disable
Over voltage definite time	U>>Td	0.03 sec	20.00 sec	0.01 sec	0.05 sec

(Table-2)

U0 / U1 / U2 Setting

Parameters	Display	Setting Range		Step Size	Default Setting
		Min	Max		
Neutral voltage pickup setting (1st stage)	U0>Pkup	2%Un	50%Un	0.5%Un	Disable
Neutral voltage characteristic	U0>Char	DEFT	IDMT	-	DEFT
Neutral voltage TMS setting	U0>Ti	0.05	2	0.01	0.05
Neutral voltage definite time (1st stage)	U0>Td	0.03 sec	20.00 sec	0.01 sec	0.05 sec
Neutral voltage pickup setting (2nd stage)	U0>>Pkup	2%Un	50%Un	0.5%Un	Disable
Neutral voltage definite time (2nd stage)	U0>>Td	0.03 sec	200.00 sec	0.01 sec	0.05 sec
Positive sequence voltage pickup setting	U1<Pkup	10%Un	100%Un	1%Un	Disable
Positive sequence voltage definite time	U1<Td	0.03 sec	10.00 sec	0.01 sec	0.10 sec
Negative sequence voltage pickup setting	U2>Pkup	10%Un	100%Un	1%Un	Disable
Negative sequence voltage definite time	U2>Td	0.03 sec	10.00 sec	0.01 sec	0.10 sec

(Table-3)

DO Assignment

Parameters	Display
Under voltage protection	U<
Under voltage hi set protection	U<<
Over voltage protection	U>
Over voltage hi set protection	U>>
Zero sequence over voltage protection (1st Stage)	U0>
Zero sequence over voltage protection (2nd Stage)	U0>>
Positive sequence under voltage protection	U1<
Negative sequence over voltage protection	U2>
Self supervision	SELF SUP
Circuit breaker open	CB open
Circuit breaker close	CB close

(Table-4)

Function Reset

Parameters	Display
Under voltage protection	U<
Under voltage hiset protection	U<<
Over voltage protection	U>
Over voltage hi set protection	U>>
Zero sequence over voltage protection (1st Stage)	U0>
Zero sequence over voltage protection (2nd Stage)	U0>>
Positive sequence under voltage protection	U1<
Negative sequence over voltage protection	U2>

(Table-5)

Erase Counter Record

Parameters	Display	Setting Range		Step Size	Default Setting
		Min	Max		
Erase Events	EventsErase	NO	YES	1	NO
Erase Faults	FaultsErase	NO	YES	1	NO

(Table-6)

Common Setting

These are the settings common for all the protections:

Parameters	Display	Setting Range		Step Size	Default Setting
		Min	Max		
Nominal frequency	FREQ(Fn)	50 Hz	60 Hz	-	50 Hz
Phase selection	PHASE	1	3	-	1
PT ratio	PTRatio	1	9999	1	1
Wire configuration	Wire confg	STAR	DELTA	-	star
Neutral displacement	NeutDisp	EXTRNL	INTRNL	-	EXTRNL
Fault Message Setting	[F]Stats	Disable	Enable	-	Disable

(Table-7)

Rear Communication (RS-485)

Description		Default Setting
Baud rate selection (programmable)	9600 / 19200 / 38400 bps	19200 bps
Parity selection (programmable)	Even / Odd / None	None
Stop bit	1 Bit	1 Bit
Data bit	8 Bit data	8 Bit data
Remote address (programmable)	247	1
Cable required for Interface	Two wire twisted shielded cable	-----

(Table-8)

Front USB Communication

Protocol	CSE Proprietary Protocol: available with front software
Baud rate	19200 bps
Cable required for Interface	USB cable type (A to A)

(Table-9)

14) Technical Data

Measuring Input

Rated data	
Rated voltage Vn	110V (In Star configuration it will be 63.5V)
	230V (Only with Star configuration)
	400V (In Star configuration it will be 230V)
Rated frequency Fn	50Hz / 60Hz

(Table-10)

Trip Time Accuracy

Parameters	Accuracy
Trip time accuracy for protections	$\pm 5\%$ OR $\pm 30\text{mSec}$ OR inaccuracy in Trip Timing in reference to $\pm 2\%$ error in measured voltage

(Table-11)

Measurement Accuracy

Parameters	Range	Frequency Range	Accuracy
Voltage	5-170%Un	50-60Hz	Less than $\pm 2\%$

(Table-12)

Trip Contact Rating

Contact rating	
Contact relay	Dry contact Ag Ni
Make current	Max. 30A & carry for 3S
Carry capacity	8A continuous
Rated voltage	250V AC / 30V DC
DC Current Carrying Capacity	8A@30VDC / 0.3A@110VDC/ 0.2A@220VDC
Breaking characteristics	
Breaking capacity AC	1500VA resistive 1500VA inductive (PF=0.5) 220V AC, 5A(cos phi=0.6)
Breaking capacity DC	135V DC, 0.3A (L/R=30ms) 250V DC, 50W resistive or 25W inductive (L/R=40ms)
Operation time	<10ms
Durability	
Loaded contact	10,000 operation minimum
Unloaded contact	30,000 operation minimum

(Table-13)

Auxiliary Supply

Rated auxiliary voltage UH	For L Model	18V-60V DC
	For H Model	85V-280V AC / 110V-300V DC
Rated supply for digital input	Normal Voltage UN	80V-260V AC (Active)
		48V-300V DC (Active)
	For H Model	<30V DC (Inactive)
		<50V AC (Inactive)
Power consumption	Normal Voltage UN	24V - 60V DC (Active)
	For L Model	<18V DC (Inactive)
	Quiescent approx. 3W	Operating approx. <7W

(Table-14)

Common Data

Dropout ratio	> 96%
Relay reset time	30 ms
Minimum operating time	30 ms
Transient overreach at instantaneous operation	±5 %

(Table-15)

Date & Time setting

Parameters	Display	Setting Range		Step Size	Default Setting
		Min	Max		
Hour	HOUR	0	23	1	---
Minute	MIN	0	59	1	---
Second	SEC	0	59	1	---
Date	DATE	1	31	1	---
Day	DAY	SUN	SAT	1	---
Month	MONTH	1	12	1	---
Year	YEAR	0	99	1	---

(Table-16)

15) Standards

Type Test			
F1	Functional Tests	Internal Design Specifications & IEC-60255-1:2022	Performance in line with Specification & Standards Pickup / Drop down / Power consumption in Current / Voltage / Aux. Supply / Trip timing accuracy: OC / NPS

Climatic Test			
C1	Temperature Dry Cold (Relay operational)	IEC-60068-2-1 : 2025	-20 deg C, 96 hours
C2	Temperature Dry Cold Transportation & Storage	IEC-60068-2-1 : 2025	-25 deg C, 96 hours
C3	Temperature Dry Heat (Relay operational)	IEC-60068-2-2 : 2025	55 deg C, 96 hours
C4	Temperature Dry Heat Transportation & Storage	IEC-60068-2-2 : 2025	70 deg C, 96 hours
C5	Damp Heat Test (Relay operational)	IEC-60068-2-78 : 2025	95% @ +55 / +25 deg C, 6 cycle (12hr + 12hr each)

Enclosure			
C6	Enclosure	IEC-60529	Front IP54 (Dust 5x + Water x4)

Mechanical Test

Relay Operational			
M1	Vibration response / Endurance test	IEC-600255-21-1 : 1988	Class I Vibration response (Relay operational) 10Hz~150 Hz - peak displacement 0.035 mm below 58/60 Hz, 0.5 g above, 1 sweep cycle in each axis Vibration endurance (Relay de-energised) 10 Hz~150 Hz 1g, 20 sweep cycles in each axis
M2	Shock Response / Withstand Test	IEC-600255-21-2 : 1988	Class I Shock response (Relay operational) 5g 11mS 3 Pulses in each axis Shock withstand (Relay de-energised) 15g 11mS 3 Pulses in each axis
M3	Bump Test	IEC 60255-21-2 : 1988	Bump (Relay de-energised) 10g 16mS 1000 pulses in each axis
M4	Seismic Test	IEC 60255-21-3 : 1993	Class I Method A single axis sine sweep 1 Hz~35 Hz - Below 8/9 Hz 3.5 mm peak displacement horizontal axis, 1.5 mm vertical axis - Above 8/9 Hz 1g horizontal, 0.5 g vertical 1 sweep cycle in each axis

Electrical Test			
E1	Insulation Resistance >100MΩ	IEC-60255-27:2023	500V DC, 5 sec between all terminals & case earth, between terminals of independent circuits including contact circuits and across open contacts
E2	DC & AC Supply Voltage (Relay operational)	IEC-60255-1:2022	Voltage range, upper & lower limit continuous withstand, ramp up & down over 1 minute
E3	Voltage Dips, Short Interruptions & Voltage variations immunity (Relay operational)	IEC-60255-26:2023 IEC-61000-4-11:2020	3 Dips & 3 Interruptions at 10 sec intervals of duration between 10mS and 500mS at zero crossings & at other points on wave Variation: 100% to 40% over 2s, hold for 1s, return to 100% over 2s
E4	Ripple in DC supply (Relay operational)	IEC-60255-26:2023	12% AC Ripple
E5	Dielectric Test (Relay de-energised) No breakdown or flash over Test voltage 45~65 Hz sinusoidal or with DC voltage at 1.4x the stated AC values	IEC-60255-27:2023	2.0 KV @ 1min All circuit to Earth / Between IP & OP
E6	High Voltage Impulse (Relay de-energised)	IEC-60255-27:2023	5 kV Peak 1.2/50uS, 0.5 Joule 3 Positive, 3 Negative between all terminals to case earth between independent circuits
E7	VT Input Thermal Withstand	IEC-60255-1:2022	1.5xVn, continuous
E8	CT Input Thermal Withstand	IEC-60255-1:2022	250xIn half wave 100xIn for 1 second 30xIn for 10 second 4xIn continuously
E9	Contact performance & endurance tests	IEC-60255-1:2022	

Electro-magnetic Compatibility			
R1	Electrical fast Transient/Burst (Relay operational)	IEC-60255-26 : 2023 IEC-61000-4-4 : 2012	Class IV- ± 4.0 kV All Circuits. Pulse 5 / 50nsec / Duration 15msec / Period:300msec/Pulse Freq: 5KHz / 2KV at I/O
R2	HF Disturbance Test (Oscillatory Waves) 1 MHz Burst (Relay operational)	IEC-60255-26 : 2023	Class III Longitudinal 2.5 kV peak, 2sec between independent circuits & case earth
R3	Electrostatic Discharge (Relay operational)	IEC-61000-4-2 : 2025 IEC-60255-26 : 2023	Class III 8kV air discharge, 6KV contact No of Discharge : 10 both polarities at 1 sec intervals
R4	Conducted Disturbance RF fields (Relay operational)	IEC-61000-4-6 : 2020 IEC-60255-26 : 2023	0.15 to 80 MHz (Level-3) Severity Level 10V RMS + sweeps 0.05-0.15 MHz & 80-100 MHz
R5	Radiated RF E-M field immunity test (Relay operational)	IEC-61000-4-3 : 2020 IEC-60255-26 : 2023	Class III Test method A + sweep 80-1000 MHz severity 10 V/m 80% modulated 1 kHz
R6	Surge Immunity capacitively coupled (Relay operational)	IEC-61000-4-5 : 2014 Class 5 Test Level 4 IEC-60255-26 : 2023	Short circuit combination wave generator 1.2 uS/50 uS open circuit repetition rate 1 per minute Power supply, CT & VT circuits – 4kV common mode 2 Ohm source 2kV differential mode 12 Ohm source
R7	Power Frequency Magnetic Field (Relay operational)	IEC-61000-4-8 : 2009	100 A/m for 1 minute in each of 3 axis (X, Y, Z)
R8	Conducted & Radiated RF Interference Emission (Relay operational)	EN 55011 : 2026 IEC-60255-26 : 2023	CISPR-11 / Class A
R9	Power Frequency, conducted common mode	IEC-60255-26 : 2023 IEC-61000-4-16 : 2015	DC to 150 kHz Test Level 4 300V at 16 ($2^{2/3}$) Hz and 50 Hz

16) Connection Diagram

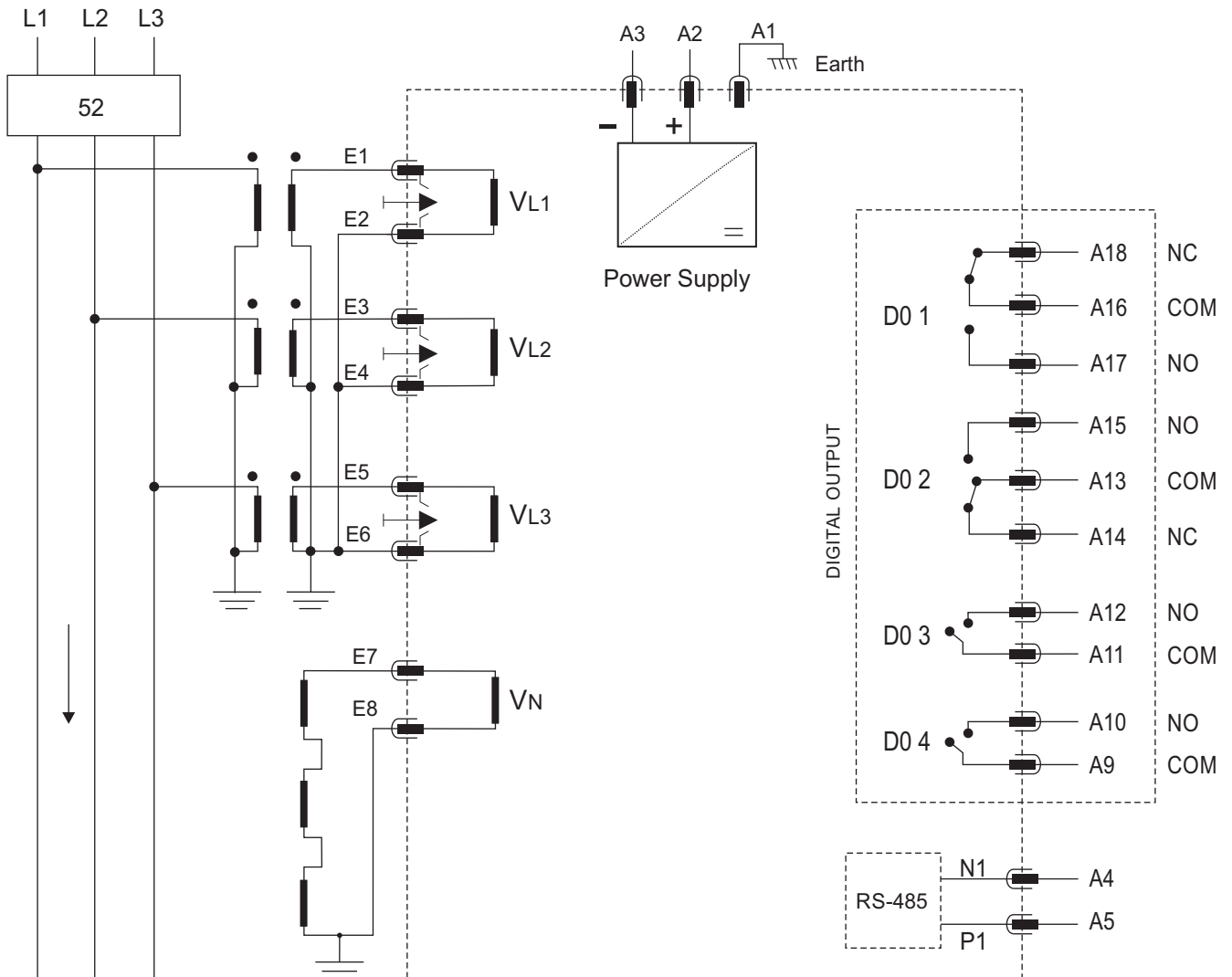

(Figure-6)

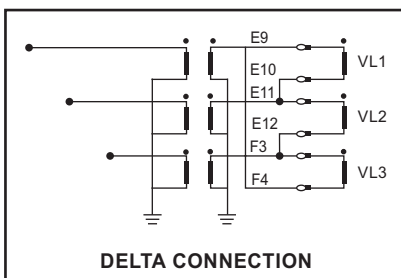

17) Dimension Details

(All the dim. are in mm, Gen. Tol.: $\pm 1.0\text{mm}$)

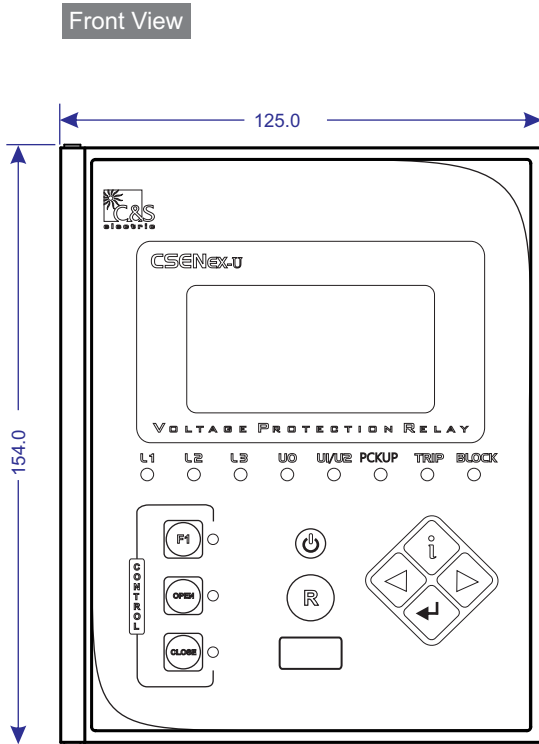

(Figure-7)

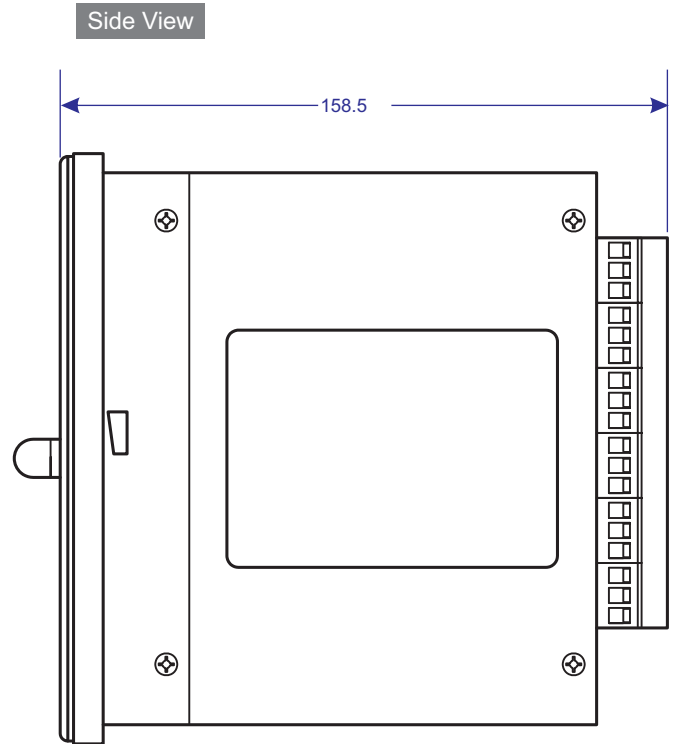

(Figure-8)

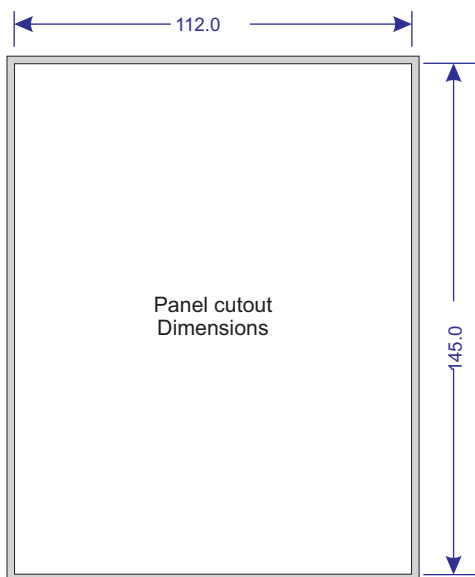

(Figure-9)



Back Terminal view of the Relay

18) Ordering Information

