

We touch your **electricity** everyday!

## CSEnEX-I

INTELLIGENT MEASURING AND PROTECTION DEVICE



Catalog

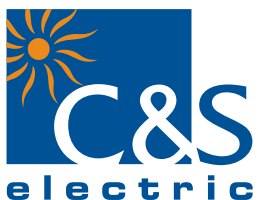

**PMD Division**

# CONTENTS

S.No.	Description
1.	Introduction
2.	Features
3.	Application
4.	Hardware
5.	Protection Features
6.	Functional Diagram
7.	Fault Record
8.	Event Record
9.	Human Machine Interface
10.	Communication
	a) Rear Communication
	b) Front Communication
11.	Setting Ranges
12.	Technical Data
13.	Technical Test
14.	Model Selection Table
15.	Standards
16.	Connection Diagram
17.	Back view of the Relay
18.	Dimensional Details
19.	Ordering Information



## 1) Introduction

CSENX Series offers a compact Multi-functional Over-current protection solution for Feeder, Generator, Motor & Transformer segment.

CSENX-I Family of protective relays are numeric relays that provides multi protection and monitoring with reliable and fast protection solution in a single unit.

In this family of CSENX series, the CSENX-I is an advanced feeder protection solution which has fast, sensitive and secure protection for feeder internal & external faults.

CSENX-I offers different model based features to cover the wide range of user.

## 2) Features

- 1A & 5A rated CT input (programmable)
- Draw out with self CT shorting
- Programmable auto-reclosing by selecting number of cycles for a particular fault
- Relay is equipped with self-supervision function
- Event recorder
- Fault recorder
- DI/DO programmable matrix
- Protection blocking through DI
- Communication (Local & Remote)

## 3) Application

The CSENX-I relays have been designed for controlling, protecting and monitoring industrial, utility distribution networks and substations. They can also be used as part of a protection scheme for feeders, transformers and generators.

## 4) Hardware

- Digital Signal Processor based numeric design
- Measures true RMS with DFT filter
- 1 A & 5A common current terminal and programmable
- 4 Current analog inputs for phase & earth fault current
- 6 Digital Inputs
- 4 Digital Outputs
- 16 x 4 Alpha-numeric LCD
- 8 LEDs at pickup and trip on fault + 3 LEDs with special function of 3 control keys
- RS-485 & USB communication

## 5) Protection Features

- Three phase time over current protection
- Three phase instantaneous protection
- Earth time over-current
- Earth instantaneous over-current
- Current unbalance / Negative Phase Sequence
- Broken conductor
- Residual over-voltage (neutral displacement)
- Circuit breaker failure protection
- Trip Circuit supervision
- Auto-Recloser

## 6) Functional Diagram

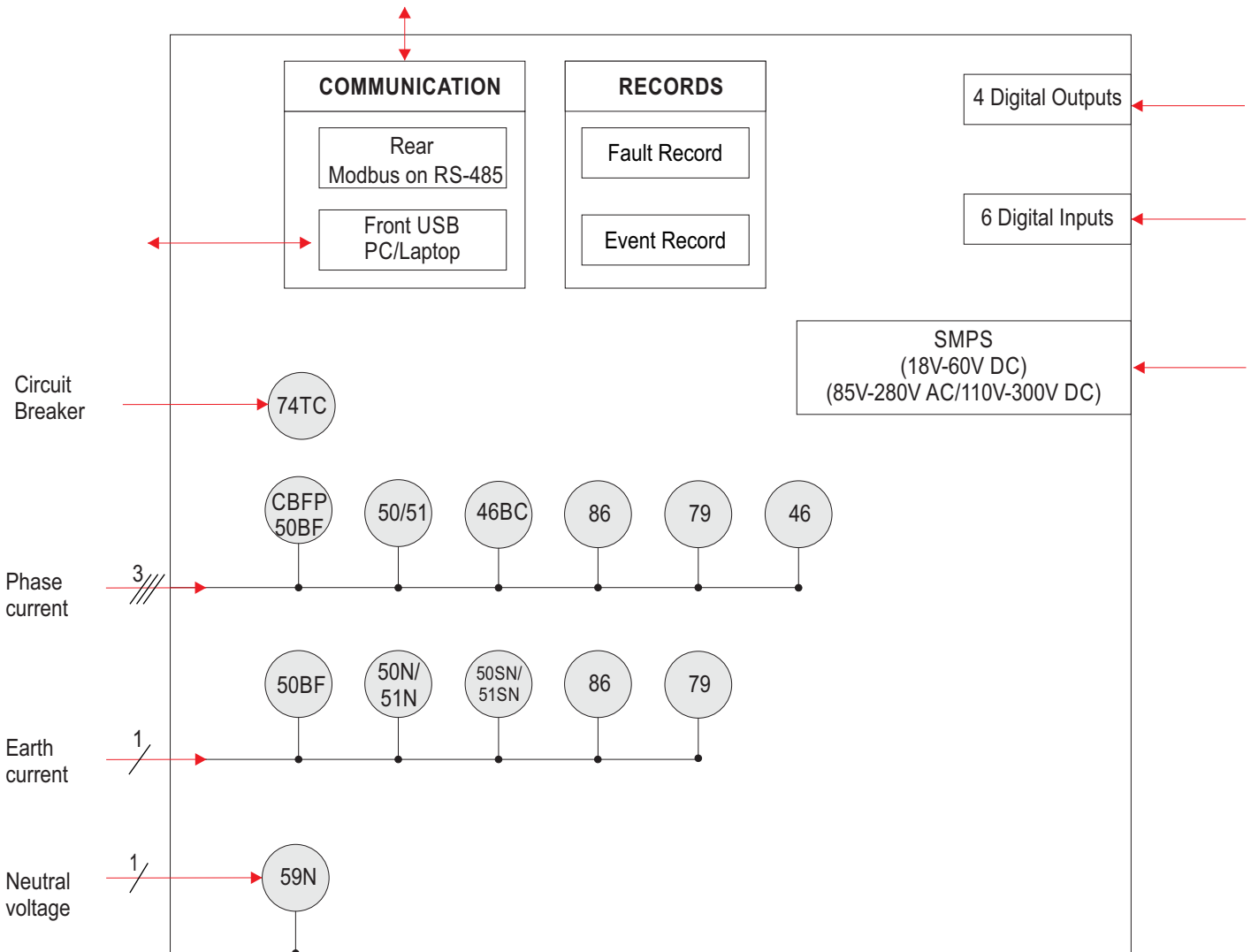

(Figure 1)

### Protection Function

#### Three Phase Over-current Protection

The independent two stages are available for phase fault protection. For  $I >$  the user may independently select definite time delay or inverse time delay with different type of curves. The second Hi-Set stage can be configured with definite time only.

#### Earth Fault Protection

The independent two stages are available for earth fault protection. For first stage ( $I_e >$ ) the user can select definite time delay or inverse time delay with different type of curves. The second Hi-Set stage can be configured with definite time only.

If neutral displacement option is selected then earth fault pick-up is considered only when neutral voltage is above the set level.

#### Broken Conductor Protection\*

For giving this protection the ratio of -ve phase sequence current and +ve phase sequence current is measured. The delay timer starts when the ratio exceeds the set value and tripping is initiated as soon as set time is elapsed.

#### Current Unbalance

It contains the inverse and definite time characteristics. This protection works exactly in the same way as phase over current but  $I_2 >$  is combination of all three current. Its amplitude also depends on the phase angle.

$$3|I_2| = |I_a + a^2 I_b + a I_c|$$

Where  $a = 1 \angle 120^\circ$

### Relay Latching

Relay can be configured to Latch/Unlatch depending on configuration. (Latching is in presence of Aux supply voltage only)

### Trip Circuit Supervision

This feature continuously supervises trip circuit of both pre closing and post closing conditions in circuit breaker. It detects tripping mechanism failure like circuit breakage contact degeneration in wires, contacts and coils.

Note: Trip counter is incremented on the basis of getting trip command from relay and not on the basis of external mechanism (circuit breaker) operation.

### Harmonic Blocking

Harmonic setting is by default 25% of injected current and takes 4 cycle to sense the harmonic injection. Phase/Earth Harmonics can be Blocked/Unblocked & time setting can also be edited through HMI. If the Pickup current has %harmonics above 25%, the protection will be blocked for the harmonics blocking time. Tripping occurs according to the higher time setting i.e. if the harmonics time setting is greater it will trip according to the harmonics time setting otherwise according to the fault time setting.

### Circuit Breaker Failure Protection

The CB Failure Protection is based on supervision of phase and earth currents after tripping events. The test criterion is whether all phase currents have dropped to less than 5% of  $I_n$  within tCBFP. If one or more of the phase currents have not dropped to specified current within this time, CB failure is detected and the assigned output relay is activated.

### Auto Recloser Strategy\*

As 80% of faults in overhead lines are transient, the use of the auto recloser is very advantageous. Automatic auto-recloser allows a substation to operate unattended. The number of visits on site to manually reclose a circuit breaker after a fault, can then be substantially reduced. This feature gives an important advantage for substations supervised remotely.

Typically this auto reclose (AR) sequence of Instantaneous Trip(s) and Reclose Delays (Dead times) followed by Delayed Trip(s) provide the automatic optimum method of clearing all types of faults i.e. both Transient and Permanent, as quickly as possible and helps in improving the up time of the network in service.

### DI Inputs:

AR Blocking - To block the auto recloser through remote DI  
CB Close DI - To get the circuit breaker status

CB Ready - To get the CB ready or to give the closing command

### Configurable Outputs:

79 : AR Close CB    79 : Lockout

### AR-Blocked:

Unit changes immediately to "AR-blocked" status when an external AR Blocking DI is applied or internal EXIT is chosen for AR cycle in HMI. No Auto reclosing is possible in "AR-blocked" status.

### Activating of AR:

Prior to every AR it is possible to select which kind of tripping ( $I>$  or  $I>>$ ,  $Ie>$  etc.) will lead to automatic re-closing. This can be separately fixed for each protection.

Dead time (td): Starts with the off signal of the circuit breaker. No closing command to the circuit breaker is given till expiry of the set dead time.

User programmable dead times are available for each protection trip operation.

The dead time is initiated when the trip output contact resets, the pickup is reset and the CB is open.

The CB close output relay is energized after the dead time has elapsed if CB ready input is present.

The dead time (dead time td1, dead time td2, dead time td3, dead time td4) starts when the feedback on 'CB CLOSE DI' is not available.

NOTE: Trip Test is available in HMI to check all LEDs and Digital Output (Relay)

### Reclaim time (tr):

This is the time during which after switching on or after AR a subsequent reclosing is prevented. If the number of the set shots is reached, the relay is locked for this time after the last re-closing attempt. If CB Ready DI is not available relay will not generate closing command.

If the circuit breaker dose not trip again, the auto re-close cycle resets to original STATE-1 at the end of the reclaim time.

If the protection operates during the reclaim time of the relay:

- \* either advances to the next AR cycle that is expected in next auto re-close state or
- \* if all the programmed re-closer attempts have been accomplished, it locks out.

The reclaim time is started with the automatic closing command.

Once a CB has re-closed and remained closed for a specified time period (the reclaim time), the AR sequence is reinitialized and a successful close output issued. A single common reclaim time is used (Reclaim Timer). when an auto re-close sequence does not result in a successful re-closure the relays goes to the lock out state.

### Starting Condition for Auto Re-closer

- 1) AR should be enabled by manual setting.
- 2) AR blocked DI is not available
- 3) Respective protection AR cycle should not in exit condition.

### Lock out State

Lockout state of the breaker means no further attempts to AR in these conditions

- 1) Lockout occurs when all auto re-closure attempts are over and protection operates during the final Reclaim Time.
- 2) If CBFP failure appeared in relay (if CBFP enable).
- 3) At the end of the each reclaim timer if the CB is in the open position (Close DI is not present).
- 4) If a Close pulse of AR relay is given and the CB fails to close through close DI input or expiry of Trip Contact Sense time.
- 5) If a open pulse given to CB and CB fails to open in between Trip Contact Sense time.

In any of these cases, Manual reset will be required to reinitiate the AR.

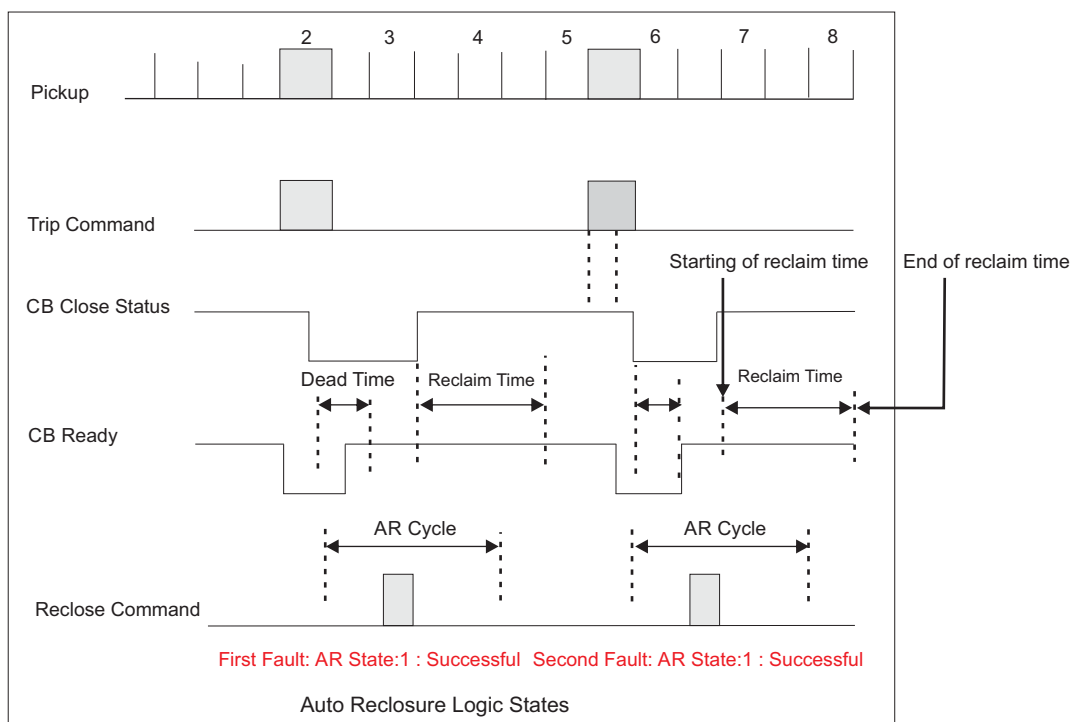

(Figure 2)

### Self Supervision Function :

One Relay can be assigned as Alarm Relay for Self Supervision. If any failure happens in the relay internal supply these contact will change its status. This contact can be configured to trip the upstream breaker.

## 7) Fault Record

CSENEX-I records last 10 faults in its non volatile memory with it's time stamp. Each record has the following information:

fault Format

[F] IL1 : 00.00A  
 [F] IL2 : 00.00A  
 [F] IL3 : 00.00A  
 [F] Ie : 00.00A  
 HOUR MIN : HH:MM  
 SEC mSEC : Sec:mSec  
 F-TYPE : FAULT TYPE

Where

[F][ILx] Magnitude of phase current's.

[F]Ie Magnitude earth fault current's

F-Type Origin of fault (over current, negative phase sequence, etc.) (See Figure 3)

whenever the available memory space is exhausted the new fault automatically over writes the oldest fault. When the relay trips the description of fault in the feeder will appears on the LCD screen automatically and by pressing  $\downarrow$  key one can easily get all the detailed information of that fault.

The user can view the fault record either via the front USB interface software or remotely via the RS-485 communication.

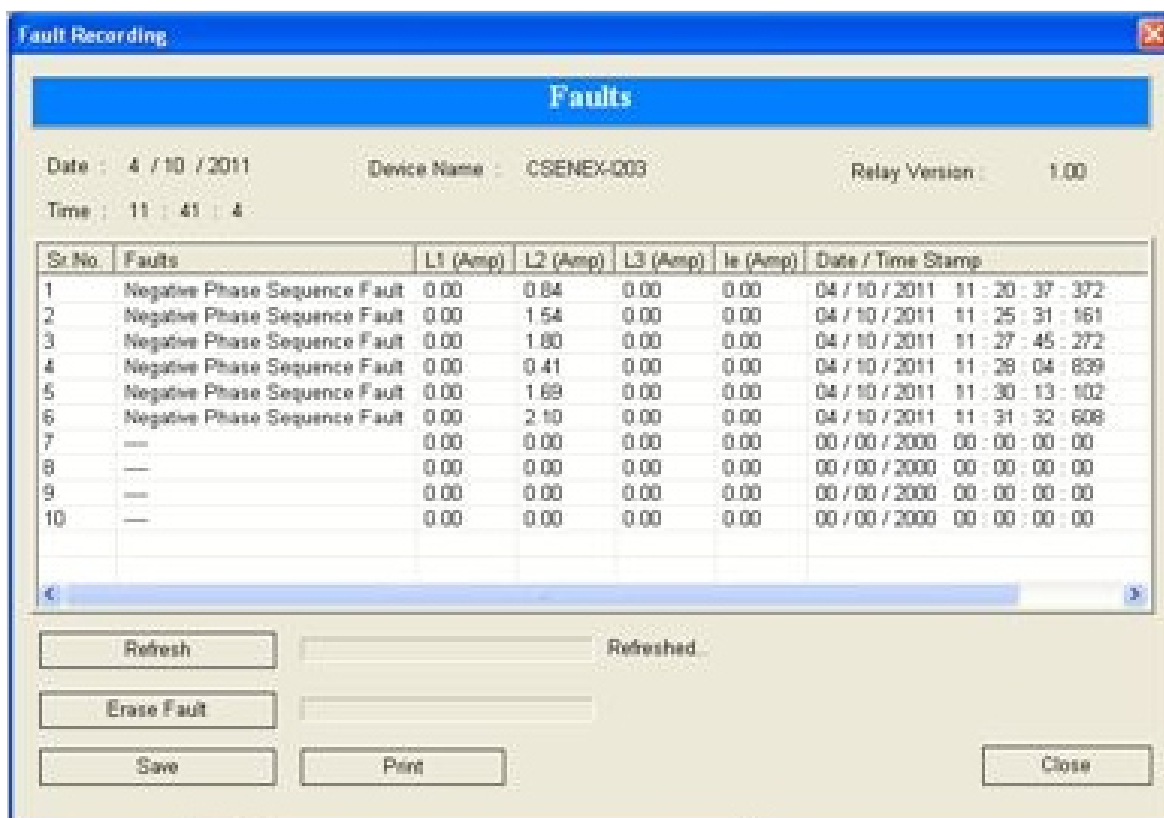

Sr.No	Faults	L1 (Amp)	L2 (Amp)	L3 (Amp)	Ie (Amp)	Date / Time Stamp
1	Negative Phase Sequence Fault	0.00	0.84	0.00	0.00	04 / 10 / 2011 11 : 20 : 37 : 372
2	Negative Phase Sequence Fault	0.00	1.54	0.00	0.00	04 / 10 / 2011 11 : 25 : 31 : 161
3	Negative Phase Sequence Fault	0.00	1.80	0.00	0.00	04 / 10 / 2011 11 : 27 : 45 : 272
4	Negative Phase Sequence Fault	0.00	0.41	0.00	0.00	04 / 10 / 2011 11 : 28 : 04 : 839
5	Negative Phase Sequence Fault	0.00	1.69	0.00	0.00	04 / 10 / 2011 11 : 30 : 13 : 102
6	Negative Phase Sequence Fault	0.00	2.10	0.00	0.00	04 / 10 / 2011 11 : 31 : 32 : 608
7	---	0.00	0.00	0.00	0.00	00 / 00 / 2000 00 : 00 : 00 : 00
8	---	0.00	0.00	0.00	0.00	00 / 00 / 2000 00 : 00 : 00 : 00
9	---	0.00	0.00	0.00	0.00	00 / 00 / 2000 00 : 00 : 00 : 00
10	---	0.00	0.00	0.00	0.00	00 / 00 / 2000 00 : 00 : 00 : 00

(Figure 3) (Fault Data Recording on PC software)

## 8) Event Record

The unit stores in non volatile memory the last 50 events. When the available memory space is exhausted, the new event automatically overwrites the oldest event which can be retrieved from a PC, with the following format:

EVENT : EVENT NUMBER  
 HOUR : HH:MM  
 SEC mSEC : SEC:mSEC  
 DATE : DD/MM/YY  
 E-TYPE : TYPE OF EVENT

- \* Date and time of the event
- \* Descriptive text of the even

The user can view event records via the front USB interface software.

- \* Description of event number available in event list or in front end software

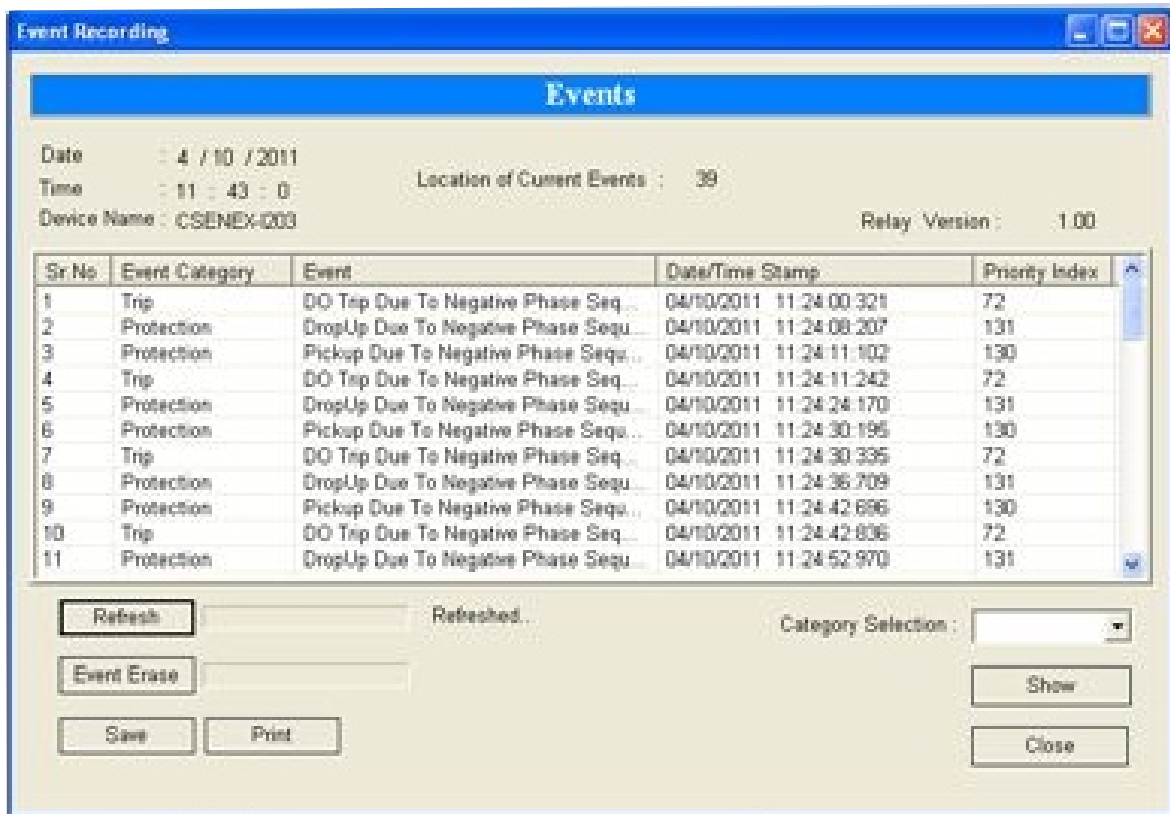

The screenshot shows a software window titled 'Event Recording' with a sub-header 'Events'. It displays the following information:

- Date : 4 / 10 / 2011
- Time : 11 : 43 : 0
- Device Name : CSENEX-003
- Location of Current Events : 39
- Relay Version : 1.00

Sr.No	Event Category	Event	Date/Time Stamp	Priority Index
1	Trip	DO Trip Due To Negative Phase Seq...	04/10/2011 11:24:00.321	72
2	Protection	DropUp Due To Negative Phase Sequ...	04/10/2011 11:24:08.207	131
3	Protection	Pickup Due To Negative Phase Sequ...	04/10/2011 11:24:11.102	130
4	Trip	DO Trip Due To Negative Phase Seq...	04/10/2011 11:24:11.242	72
5	Protection	DropUp Due To Negative Phase Sequ...	04/10/2011 11:24:24.170	131
6	Protection	Pickup Due To Negative Phase Sequ...	04/10/2011 11:24:30.195	130
7	Trip	DO Trip Due To Negative Phase Seq...	04/10/2011 11:24:30.335	72
8	Protection	DropUp Due To Negative Phase Sequ...	04/10/2011 11:24:36.709	131
9	Protection	Pickup Due To Negative Phase Sequ...	04/10/2011 11:24:42.896	130
10	Trip	DO Trip Due To Negative Phase Seq...	04/10/2011 11:24:42.806	72
11	Protection	DropUp Due To Negative Phase Sequ...	04/10/2011 11:24:52.970	131

At the bottom of the window, there are several controls: a 'Refresh' button, a 'Category Selection' dropdown menu, an 'Event Erase' button, 'Save' and 'Print' buttons, and 'Show' and 'Close' buttons.

(Figure 4) (Event Data Recording on PC Software)







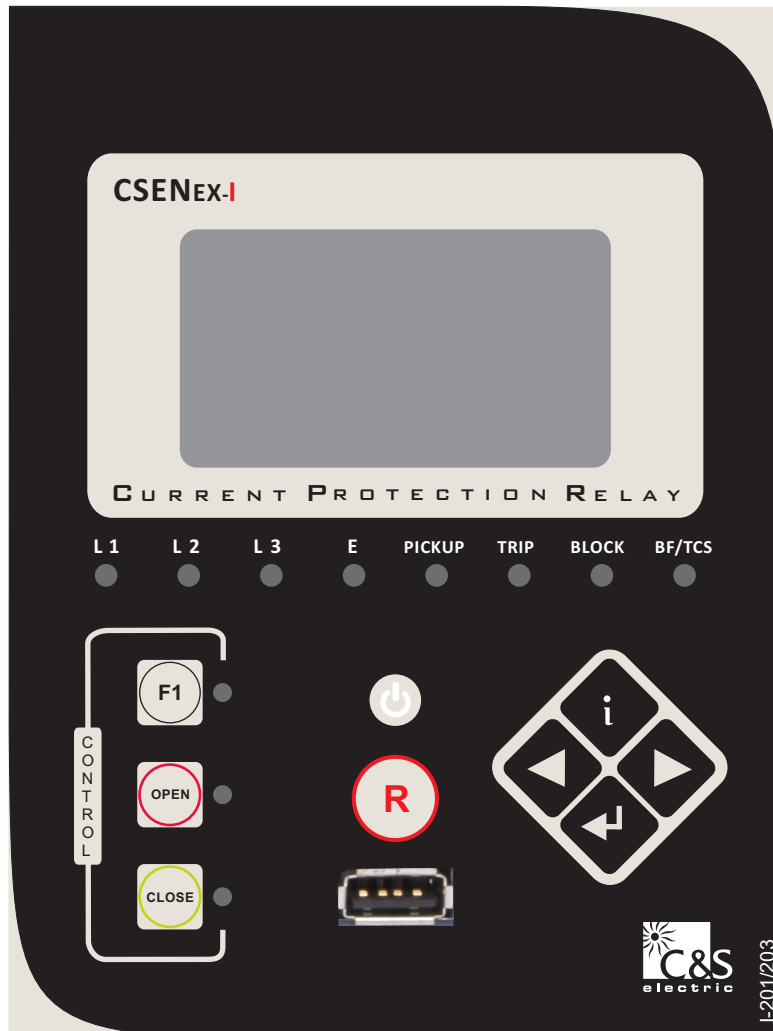

## 9) Human Machine Interface

It comprises of bright LCD display

- Four push switches for setting values of normal tripping characteristics and other operations for local access.
- One RESET push switch.
- One push switch for the functions assigned in the HMI to F1 key, 2 push switch to open or close circuit breaker
- Eight LEDs for pickup or tripping on fault and event in any phase.



(Figure 5) (HMI)

Keys	Manual Key
	is used as intelligent key to see the details of last fault and Relay status.
	is used as a ENTER key.
	is used to manual reset (after pressing for 2 sec).
	is used to scroll in backward direction.
	is used to scroll in forward direction.
	To perform the assigned task either DO trip or Relay reset.
	To open the circuit breaker.
	To close the circuit breaker.

### Output Contacts

No. of digital outputs	:	4 (DO1, DO2, DO3, DO4) [2 Change over (DO1, DO2), 2 Normal open (DO3, DO4)]
Type of outputs	:	Relay
Programmable (DO Assignment)	:	Yes
Relay reset type	:	Programmable (Auto/Manual)

### Input Contacts

No of digital inputs	:	6 (DI1, DI2, DI3, DI4, DI5, DI6) for CSENEX-I 202 & 203 model 4 (DI1, DI2, DI3, DI4) for 201 model
Type of inputs	:	Depends upon the version
Programmable (DI Assignment)	:	Programmable

## 10) Communication (Local and Remote)

The unit has:

- \* 1 Front USB port for direct connection to a PC
- \* 1 Rear RS-485 communication port

### a) Rear Communication

The protocol for the rear port is MODBUS-RTU.

### b) Front Communication

The entire setting, Fault & Event are available on 'A' type USB (female) interface with CSE LIVELINK with saving & printing option. This unit also has Front-end Live Link simulation support for testing of relay even without any three phase injection source.

## 11) Setting Ranges

### Over Current and Earth Protection

S. No	Parameter	Display	Setting Range		Step Size	Default Setting
			Min.	Max.		
1	Phase characteristics	P-Char			DEFT/EINV/VINV /LINV/NINV1.3/ NINV3.0/NINV0.6	DEFT
2	Earth Characteristics	E-Char			DEFT/EINV/VINV /LINV/NINV1.3/ NINV3.0/NINV0.6	DEFT
3	Phase over-current low set pickup setting Phase over-current definite timing Phase over-current inverse timing	I> t> ti>	0.20xI <sub>p</sub> 0.05 Sec 0.01	4.0xI <sub>p</sub> 150 Sec 1.50	0.01xI <sub>p</sub> 0.01Sec 0.005	EXIT 0.10 Sec 0.05
4	Phase over-current hi-set pickup setting Phase over-current hi-set definite timing	I>> t>>	0.5xI <sub>p</sub> 0.02 Sec	30xI <sub>p</sub> 20 Sec	0.1xI <sub>p</sub> 0.01Sec	EXIT 0.10 Sec
5	**Earth over-current low set pickup setting Earth over-current low set definite timing Earth over-current low set inverse timing	Ie> te> tie>	0.05xI <sub>n</sub> 0.03 Sec 0.01	2.5xI <sub>n</sub> 150 Sec 1.50	0.01xI <sub>n</sub> 0.01Sec 0.005	EXIT 0.10 Sec 0.05
6	**Earth over-current hi-set pickup setting Earth over-current hi-set definite timing	Ie>> te>>	0.5xI <sub>n</sub> 0.02 Sec	8xI <sub>n</sub> 20 Sec	0.05xI <sub>n</sub> 0.01 Sec	EXIT 0.10 Sec

Note: All parameters are Password protected

$$\begin{aligned} \text{Very Inverse} \quad t &= \frac{13.5}{(I/I_s) - 1} \quad t_i \text{ [s]} \\ \text{Extremely Inverse} \quad t &= \frac{80}{(I/I_s)^2 - 1} \quad t_i \text{ [s]} \\ \text{Long time Inverse} \quad t &= \frac{120}{(I/I_s) - 1} \quad t_i \text{ [s]} \\ \text{Normal Inverse 3.0/1.3/0.6} \quad t &= \frac{0.14/0.061/0.028}{(I/I_s)^{0.02} - 1} \quad t_i \text{ [s]} \end{aligned}$$

Where  $t$  = Tripping time  $t_i$  = Time multiplier  
 $I$  = Fault current  $I_s$  = Setting value of current

Trip timing Accuracy : DEFT/ NINV 0.6 / NINV 3.0 / 1.3 :  $\pm 5\%$  OR  $\pm 30\text{mSec}$  (whichever is higher)  
 EINV / VINV / LINV :  $\pm 7.5\%$  OR  $\pm 40\text{mSec}$  (whichever is higher)

#### Trip Circuit Supervision Protection \*

S.No.	Parameter	Display	Setting Range		Step Size	Default Setting
			Min.	Max.		
1	Enable TCS	Enable	NO	YES	-----	NO
2	TCS	t_TCS	0.05 Sec	2 Sec	0.01	0.05 Sec

Note: t\_TCS max setting is 5 Sec for 203 model

#### Circuit Breaker Failure Protection

S.No.	Parameter	Display	Setting Range		Step Size	Default Setting
			Min.	Max.		
1	Enable CBFP	Enable	NO	YES	-----	NO
2	CBFP	t_CBFP	0.05 Sec	2 Sec	0.01	0.05 Sec

Note: t\_CBFP max setting is 5 Sec for 203 model

#### Negative Phase Sequence Setting \*

S.No.	Parameter	Display	Setting Range		Step Size	Default Setting
			Min.	Max.		
1	Enable NPS	Enable	NO	YES	-----	YES
2	NPS characteristics	Char	DEFT	NPS-INV	-----	DEFT
3	Pick up current	lb	0.10xlp	2.5xlp	0.01xlp	0.10xlp
4	Time multiple	K1	5.0	600	1.0	5 Sec
5	Definite time	td	0.10	600	0.10	0.20 Sec

Note = \* Availability as per model selection.

### Negative Phase Sequence Equation

$$t = \frac{K1}{(I2/Ib)^2 - 1}$$

Where I2 is injected NPS current.

Trip timing accuracy :  $\pm 7.5\%$  OR  $\pm 40\text{mSec}$  (whichever is higher)

### Broken Conductor Setting \*

S.No.	Parameter	Display	Setting Range Step		Default Size	Setting
			Min.	Max.		
1	Enable broken conductor	Enable	NO	YES	----	NO
2	NPS-PPS Ratio	I2/I1	0.10	0.50	0.01	0.10
3	Definite trip time	tcon	0.05 Sec	20 Sec	0.01 Sec	0.05 Sec

### Harmonic Restrain \*

S.No.	Parameter	Display	Setting Range		Step Size	Default Setting
			Min.	Max.		
1	Enable Phase block	PH Block	NO	YES	----	NO
2	Phase Blocking time	tPHASE	0.0 Sec	20 Sec	0.1	0.0 Sec
3	Enable Earth block	E Block	NO	YES	----	NO
4	Earth Blocking time	tEARTH	0.0 Sec	20 Sec	0.1	0.0 Sec

### DI Blocking \*

S.No.	Parameter	Display	Setting Range		Step Size	Default Setting
			Min.	Max.		
1	Phase over-current low set	I>	Unblock	Block	----	Unblock
2	Phase over-current hi-set	I>>	Unblock	Block	----	Unblock
3	Earth over-current low set	Ie>	Unblock	Block	----	Unblock
4	Earth over-current hi-set	Ie>>	Unblock	Block	----	Unblock
5	Negative Phase sequence	I2>	Unblock	Block	----	Unblock
6	Broken conductor	BC	Unblock	Block	----	Unblock
7	Auto Re-closer	AR	Unblock	Block	----	Unblock

### DI Assignment \*

Parameter	Display
Digital Input 1	DI-1
Digital Input 2	DI-2
Digital Input 3	DI-3
Digital Input 4	DI-4
Digital Input 5	DI-5
Digital Input 6	DI-6

Note = \* Availability as per model selection.

### Following functions can be assigned to the 6 DIs

S.No.	I 201 (Configurable)	I 202 (Configurable)	I 203 (Configurable)
1	CB Close	CB Close	CB Close
2	CB Open	CB Open	CB Open
3	Protection Block	CB Ready	CB Ready
4	Remote Reset	AR Block	AR Block
5	Remote Trip 1	Remote Trip 1	Remote Trip 1
6	Remote Trip 2	Remote Trip 2	Remote Trip 2
7	Remote Trip 3	Remote Trip 3	Remote Trip 3
8	---	Protection Block	Protection Block
9	---	Remote Reset	Remote Reset

### DO Assignment \*

S.No	Parameter	Display	Setting Range		Step Size	Default Setting
			Min.	Max.		
1	Phase over-current low set	I>	---	---	DO1/DO2/DO3/DO4	---
2	Phase over-current hi-set	I>>	---	---	DO1/DO2/DO3/DO4	---
3	Earth over-current low set	Ie>	---	---	DO1/DO2/DO3/DO4	---
4	Earth over-current hi-set	Ie>>	---	---	DO1/DO2/DO3/DO4	---
5	Self supervision	SELF SUP	---	---	DO1/DO2/DO3/DO4	---
6	Circuit breaker failure protection	CBFP	---	---	DO1/DO2/DO3/DO4	---
7	Negative phase sequence	I2>	---	---	DO1/DO2/DO3/DO4	---
8	Broken conductor	Broken cond	---	---	DO1/DO2/DO3/DO4	---
9	Trip circuit supervision	TCS	---	---	DO1/DO2/DO3/DO4	---
10	Circuit breaker open	CB_Open	---	---	DO1/DO2/DO3/DO4	---
11	Circuit breaker close	CB_Close	---	---	DO1/DO2/DO3/DO4	---
12	Auto Re-closer Relay	AR Close	---	---	DO1/DO2/DO3/DO4	---
13	Lockout relay	AR Lockout	---	---	DO1/DO2/DO3/DO4	---

### Function Reset \*

S.No.	Parameter	Display	Setting Range		Step Size	Default Setting
			Min.	Max.		
1	Phase over-current low set	I>	Auto	Manual	-----	Auto
2	Phase over-current hi set	I>>	Auto	Manual	-----	Auto
3	Earth over-current low set	Ie>	Auto	Manual	-----	Auto
4	Earth over-current hi set	Ie>>	Auto	Manual	-----	Auto
5	Negative phase sequence	I2>	Auto	Manual	-----	Auto
6	Broken conductor	BC	Auto	Manual	-----	Auto
7	Auto recloser	AR	Auto	Manual	-----	Auto

Note = \* Availability as per model selection.

### Auto Re-closer Mode \*

S.No.	Parameter	Display	Setting Range		Step Size	Default Setting
			Min.	Max.		
1	Enable Auto-recloser	Enable	Yes	No		Yes
2	Dead time 1	D1	0.20 Sec	300 Sec	0.01 Sec	0.20 Sec
3	Dead time 2	D2	0.20 Sec	300 Sec	0.01 Sec	0.20 Sec
4	Dead time 3	D3	0.20 Sec	300 Sec	0.01 Sec	0.20 Sec
5	Dead time 4	D4	0.20 Sec	300 Sec	0.01 Sec	0.20 Sec
6	Reclaim time	tR	0.20 Sec	300 Sec	0.01 Sec	0.20 Sec
7	Phase over-current low set max AR cycle	I>cycle	2	4	1	2
8	Phase over-current hi-set max AR cycle	I>>cycle	2	4	1	2
9	Earth over-current low set max AR cycle	Ie>cycle	2	4	1	2
10	Earth over-current hi-set max AR cycle	Ie>>cycle	2	4	1	2
11	Trip sense time	t_TST	0.05 Sec	2 Sec	0.01 Sec	0.05 Sec

**Note: t\_TST max setting is 5 Sec for 203 model**

### Key Assignment \*

S.No.	Parameter	Display	Setting Range		Step Size	Default Setting
			Min.	Max.		
1	Function key	F1	----	----	DO1/DO2/DO3 DO4/Relay Reset	DO1

### Neutral Displacement Setting \*

S.No.	Parameter	Display	Setting Range		Step Size	Default Setting
			Min.	Max.		
1	Enable neutral displacement	Enable	NO	YES	-	NO
2	Neutral Voltage	Vn	2V	50V	1V	7V

### General Setting (These are the settings common for all protections)

S.No.	Parameter	Display	Setting Range		Step Max.	Default SizeSetting
				Min.		
1	Rated phase current	I <sub>p</sub>	1.00 Amp	5.00 Amp	-----	1.00 Amp
2	Rated earth current	I <sub>n</sub>	1.00 Amp	5.00 Amp	-----	1.00 Amp
3	Phase CT ratio	PCTRATIO	1	7000	1	1
4	Earth CT ratio	ECTRATIO	1	7000	1	1
5	Nominal frequency	RATDFREQ	50 Hz	60 Hz	-----	50 Hz

### Rear communication

(\*Availability as per Model Selection)

Protocol	MODBUS RTU
Baud rate selection (programmable)	4800/9600/19200/38400/57600bps
Parity selection (programmable)	Even / Odd / None
Stop bit	1 Bit
Data bit	8 Bit data
Remote Address (programmable)	(1 to 247)
Cable required for interface	Two wire twisted shielded cable

### Front communication

Protocol	CSE proprietary protocol: available with front software
Baud rate	19200 bps
Cable required for interface	USB cable type (A to A)

### Auxiliary Supply

Auxiliary Voltage Range	For L Model	18V-60V DC
	For H Model	85V-280V AC / 110V-300V DC
Supply Range for Digital Input	For L & H Model	Above 24V AC/DC
Power Consumption	Quiescent approx. 3W	Operating approx. <7W

### Measurement Accuracy

S.No	Quantity	Range	Frequency Range	Accuracy
1	Current	1 - 30 xlp	50 - 60 Hz	$\pm 2\%$
2	Voltage	5 - 40V	50 - 60 Hz	$\pm 2\%$

### Pickup Accuracy

S.No	Quantity	Range	Frequency Range	Accuracy
1	Current	1 - 30 xlp	50 - 60 Hz	+5% of Pickup setting
2	Voltage	5 - 40V	50 - 60 Hz	+6% of Pickup setting

## 12) Technical Data

### Measuring Inputs

Rated Data	Rated current $I_p$ : 1A or 5A
	Rated frequency $F_n$ : 50 Hz/60Hz
Drop out to Pickup Ratio	>96%
Power consumption in current circuit	At $I_p=1A$ 0.2 VA At $I_p=5A$ 0.4 VA
Thermal withstand capability in current circuit	Dynamic current withstand (half wave): 250 x $I_p$ for 1 Sec : 100 x $I_p$ for 10 Sec : 30 x $I_p$ continuously : 4 x $I_p$

### Trip Contact Rating

Contact Rating	
Contact relay	Dry contact Ag Ni
Make current	Max. 30A & carry for 3S
Carry capacity	8A continuous : Relay 1
	4A continuous : Relay 2, 3, 4
Rated voltage	250V AC/ 30V DC
DC Current Carrying Capacity	8A@30VDC / 0.3A@110VDC/ 0.2A@220VDC
Breaking Characteristics	
Breaking capacity AC	1500VA resistive
	1500VA inductive (PF=0.5)
Breaking capacity DC	220V AC, 5A ( $\cos\theta \leq 0.6$ )
	135V DC, 0.3A (L/R=30ms)
	250V DC, 50W resistive or 25W inductive (L/R=40ms)
Operation time	<10ms
Durability	
Loaded contact	10,000 operation minimum
Unloaded contact	30,000 operation minimum

Over-voltage category : II, Insulation voltage : 300V, Pollution Degree : 2, IP 54 from Front

### 13) Technical Test

Shock	As per DIN IEC 41 B (CO) 38: class 1
Vibration	As per DIN IEC 41 B (CO) 35: class 1
Protection-Front Panel	IP 54
Protection-Rear Panel	IP 00
Weight	Approx. 1.0 Kg

### 14) Model Selection Table

Function	ANSI	NEX-I 201	NEX-I 202	NEX-I 203
CT inputs	-	4	4	4
PT inputs	-	x	x	1
Over current	50/51	✓	✓	✓
Earth Fault	50N/51N	✓	✓	✓
Neutral displacement	59N	x	x	✓
CBFP	50BF	✓	✓	✓
Unbalance	46	✓	✓	✓
Trip circuit	74TC	✓	✓	✓
Harmonic blocking	50H	✓	✓	✓
Broken conductor	46BC	x	✓	✓
Auto Re-closer	79	x	✓	✓
Digital input	-	4	6	6
Digital output	-	4	4	4
Fault record	-	10	10	10
Event record	-	50	50	50
Selection of 1/5A	-	Site selectable	Site selectable	Site selectable
Enclosure type	-	Draw out with CT CT shorting	Draw out with CT shorting	Draw out with CT shorting
Enclosure (WxHxD) mm	-	(125x154x156)	(125x154x156)	(125x154x156)
Front communication	-	✓	✓	✓
Rear comm. (RS-485)	-	✓	✓	✓

## Inverse Graph Representation

### Inverse Time Characteristics

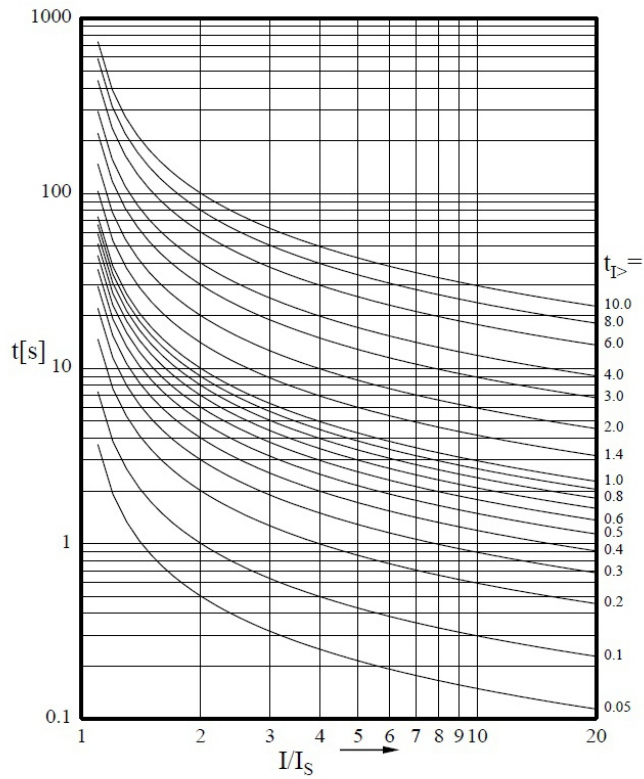

*Normal Inverse*

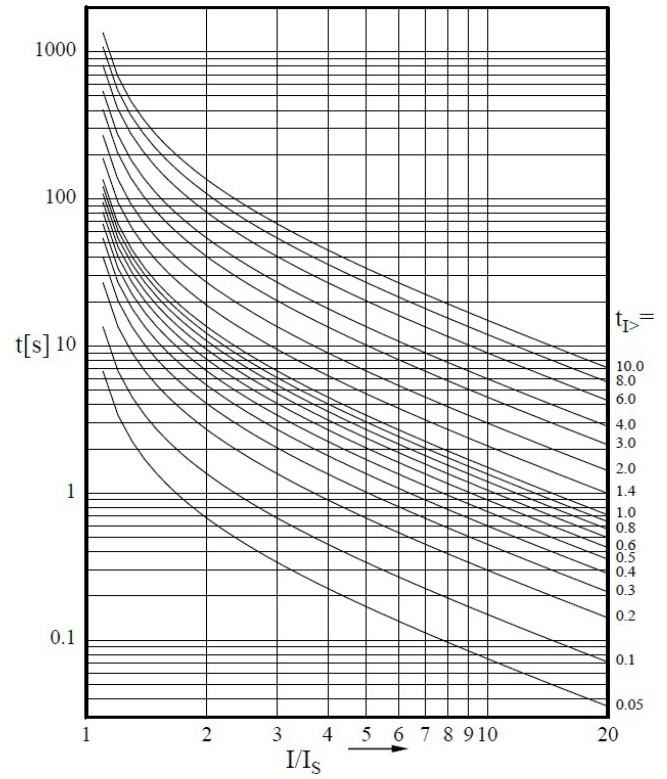

*Very Inverse*

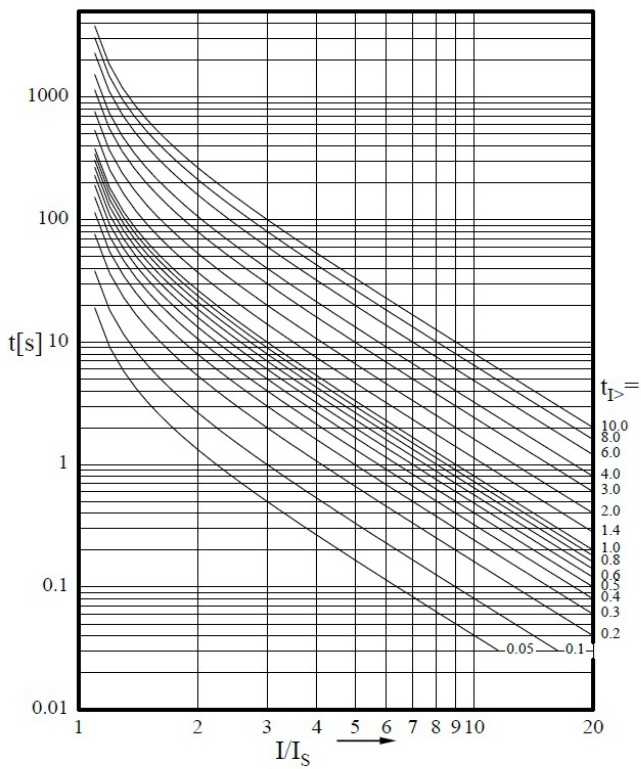

*Extremely Inverse*

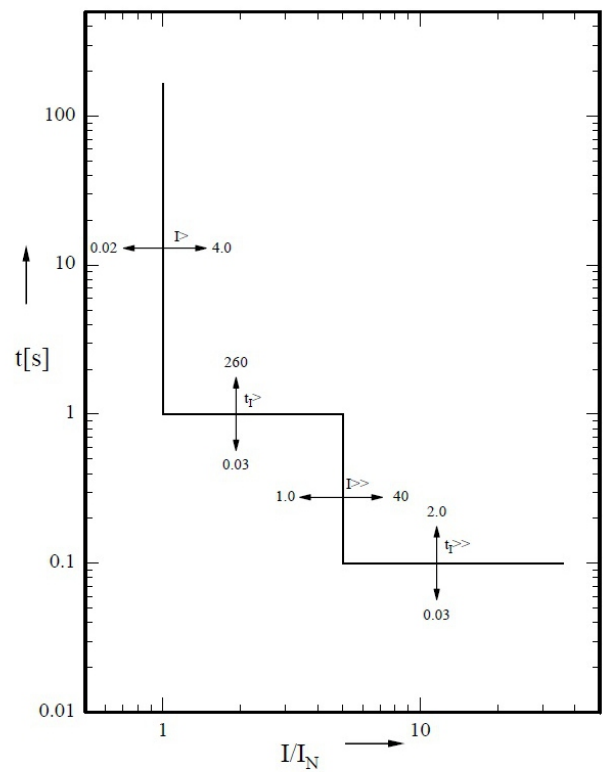

*Definite time overcurrent relay*

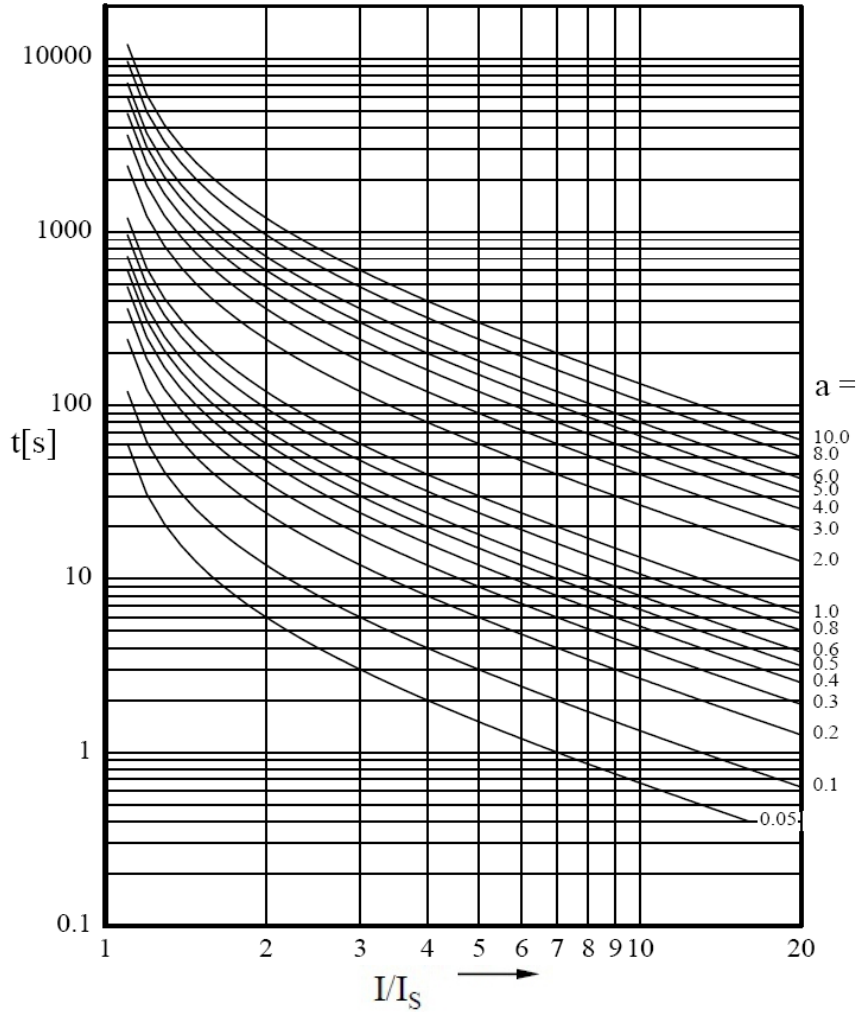

*Long time inverse*

## 15) Standards

Type Test			
F1	Functional Tests	Internal Design Specifications & IEC-60255-1:2022	Performance in line with Specification & Standards Pickup / Drop down / Power consumption in Current / Voltage / Aux. Supply / Trip timing accuracy: OC / NPS

Climatic Test			
C1	Temperature Dry Cold (Relay operational)	IEC-60068-2-1 : 2025	-20 deg C, 96 hours
C2	Temperature Dry Cold Transportation & Storage	IEC-60068-2-1 : 2025	-25 deg C, 96 hours
C3	Temperature Dry Heat (Relay operational)	IEC-60068-2-2 : 2025	55 deg C, 96 hours
C4	Temperature Dry Heat Transportation & Storage	IEC-60068-2-2 : 2025	70 deg C, 96 hours
C5	Damp Heat Test (Relay operational)	IEC-60068-2-78 : 2025	95% @ +55 / +25 deg C, 6 cycle (12hr + 12hr each)

Enclosure			
C6	Enclosure	IEC-60529	Front IP54 (Dust 5x + Water x4)

### Mechanical Test

Relay Operational			
M1	Vibration response / Endurance test	IEC-600255-21-1 : 1988	Class I Vibration response (Relay operational) 10Hz~150 Hz - peak displacement 0.035 mm below 58/60 Hz, 0.5 g above, 1 sweep cycle in each axis Vibration endurance (Relay de-energised) 10 Hz~150 Hz 1g, 20 sweep cycles in each axis
M2	Shock Response / Withstand Test	IEC-600255-21-2 : 1988	Class I Shock response (Relay operational) 5g 11mS 3 Pulses in each axis Shock withstand (Relay de-energised) 15g 11mS 3 Pulses in each axis
M3	Bump Test	IEC 60255-21-2 : 1988	Bump (Relay de-energised) 10g 16mS 1000 pulses in each axis
M4	Seismic Test	IEC 60255-21-3 : 1993	Class I Method A single axis sine sweep 1 Hz~35 Hz - Below 8/9 Hz 3.5 mm peak displacement horizontal axis, 1.5 mm vertical axis - Above 8/9 Hz 1g horizontal, 0.5 g vertical 1 sweep cycle in each axis

Electrical Test			
E1	Insulation Resistance >100MΩ	IEC-60255-27:2023	500V DC, 5 sec between all terminals & case earth, between terminals of independent circuits including contact circuits and across open contacts
E2	DC & AC Supply Voltage (Relay operational)	IEC-60255-1:2022	Voltage range, upper & lower limit continuous withstand, ramp up & down over 1 minute
E3	Voltage Dips, Short Interruptions & Voltage variations immunity (Relay operational)	IEC-60255-26:2023 IEC-61000-4-11:2020	3 Dips & 3 Interruptions at 10 sec intervals of duration between 10mS and 500mS at zero crossings & at other points on wave Variation: 100% to 40% over 2s, hold for 1s, return to 100% over 2s
E4	Ripple in DC supply (Relay operational)	IEC-60255-26:2023	12% AC Ripple
E5	<b>Dielectric Test</b> (Relay de-energised) No breakdown or flash over Test voltage 45~65 Hz sinusoidal or with DC voltage at 1.4x the stated AC values	IEC-60255-27:2023	2.0 KV @ 1min All circuit to Earth / Between IP & OP
E6	High Voltage Impulse (Relay de-energised)	IEC-60255-27:2023	5 kV Peak 1.2/50uS, 0.5 Joule 3 Positive, 3 Negative between all terminals to case earth between independent circuits
E7	VT Input Thermal Withstand	IEC-60255-1:2022	1.5xVn, continuous
E8	CT Input Thermal Withstand	IEC-60255-1:2022	250xIn half wave 100xIn for 1 second 30xIn for 10 second 4xIn continuously
E9	Contact performance & endurance tests	IEC-60255-1:2022	

Electro-magnetic Compatibility			
R1	Electrical fast Transient/Burst (Relay operational)	IEC-60255-26 : 2023 IEC-61000-4-4 : 2012	Class IV- $\pm 4.0$ kV All Circuits. Pulse 5 / 50nsec / Duration 15msec / Period:300msec/Pulse Freq: 5KHz / 2KV at I/O
R2	HF Disturbance Test (Oscillatory Waves) 1 MHz Burst (Relay operational)	IEC-60255-26 : 2023	Class III Longitudinal 2.5 kV peak, 2sec between independent circuits & case earth
R3	Electrostatic Discharge (Relay operational )	IEC-61000-4-2 : 2025 IEC-60255-26 : 2023	Class III 8kV air discharge, 6KV contact No of Discharge : 10 both polarities at 1 sec intervals
R4	Conducted Disturbance RF fields (Relay operational)	IEC-61000-4-6 : 2020 IEC-60255-26 : 2023	0.15 to 80 MHz (Level-3) Severity Level 10V RMS + sweeps 0.05-0.15 MHz & 80-100 MHz
R5	Radiated RF E-M field immunity test (Relay operational)	IEC-61000-4-3 : 2020 IEC-60255-26 : 2023	Class III Test method A + sweep 80-1000 MHz severity 10 V/m 80% modulated 1 kHz
R6	Surge Immunity capacitively coupled (Relay operational)	IEC-61000-4-5 : 2014 Class 5 Test Level 4 IEC-60255-26 : 2023	Short circuit combination wave generator 1.2 uS/50 uS open circuit repetition rate 1 per minute Power supply, CT & VT circuits – 4kV common mode 2 Ohm source 2kV differential mode 12 Ohm source
R7	Power Frequency Magnetic Field (Relay operational)	IEC-61000-4-8 : 2009	100 A/m for 1 minute in each of 3 axis (X, Y, Z)
R8	Conducted & Radiated RF Interference Emission (Relay operational)	EN 55011 : 2026 IEC-60255-26 : 2023	CISPR-11 / Class A
R9	Power Frequency, conducted common mode	IEC-60255-26 : 2023 IEC-61000-4-16 : 2015	DC to 150 kHz Test Level 4 300V at $16^{(2/3)}$ Hz and 50 Hz

## 16) Connection Diagram

CSENEX-I 201

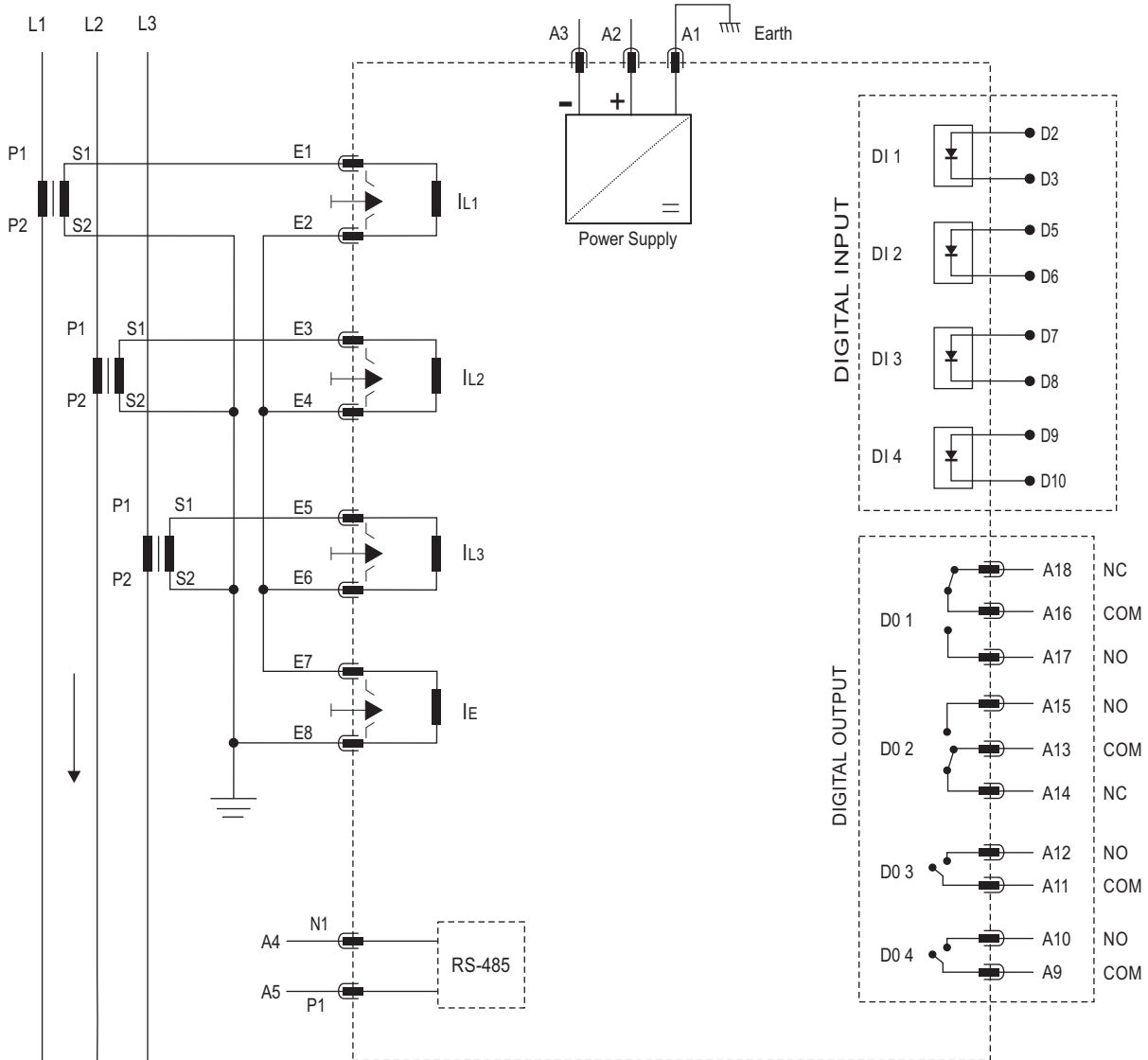

(Figure 7)

### Terminal Description

Terminal Name	Terminal Description
A1	: Power Supply Earth
A2-A3	: Power Supply
A4-A5	: RS-485 Modbus N1(A4), P1(A5)
A9-A10	: Potential free Digital Output 4
A11-A12	: Potential free Digital Output 3
A13-A14-A15	: Potential free Digital Output 2
A16 -A17- A18	: Potential free Digital Output 1
D3-D2	: Potential Digital Input 1
D5-D6	: Potential Digital Input 2
D7-D8	: Potential Digital Input 3
D9-D10	: Potential Digital Input 4
E1-E6	: CT Terminal for Phase current input L1(E1-E2), L2(E3-E4),L3(E5-E6)
E7-E8	: CT Terminal for Earth current input

## Connection Diagram

CSENX-I 202

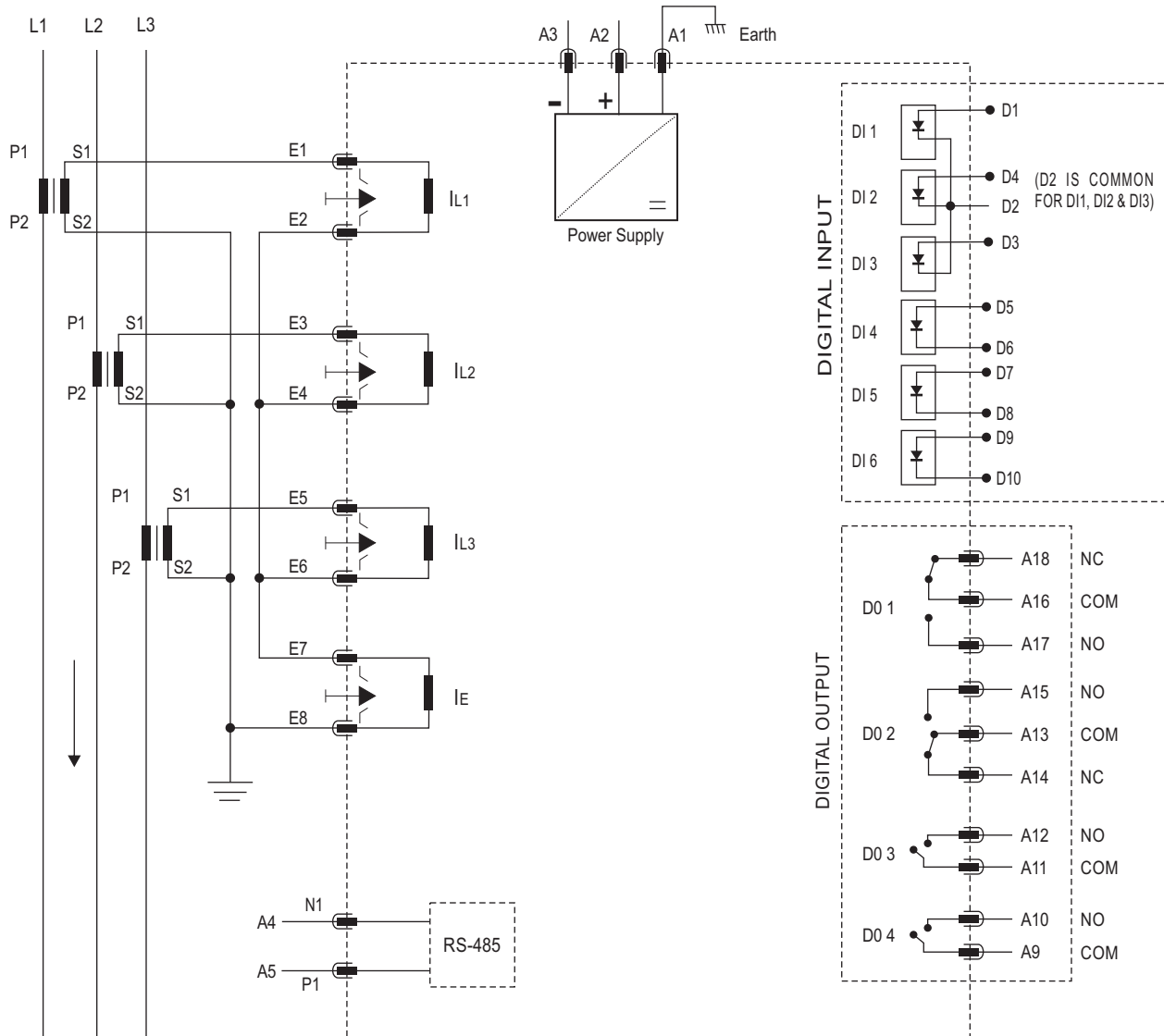

(Figure 8)

## Terminal Description

Terminal Name	Terminal Description
A1	: Auxiliary Supply Earth
A2-A3	: Auxiliary Supply
A4-A5	: RS-485 Modbus N1(A4), P1(A5)
A9-A10	: Potential free Digital Output 4
A11-A12	: Potential free Digital Output 3
A13-A14-A15	: Potential free Digital Output 2
A16 -A17- A18	: Potential free Digital Output 1
D1-D2	: Potential Digital Input 1
D4-D2	: Potential Digital Input 2
D3-D2	: Potential Digital Input 3
D5-D6	: Potential Digital Input 4
D7-D8	: Potential Digital Input 5
D9-D10	: Potential Digital Input 6
E1-E6	: CT Terminal for Phase current input L1(E1-E2), L2(E3-E4), L3(E5-E6)
E7-E8	: CT Terminal for Earth current input

## Connection Diagram

CSENX-I 203

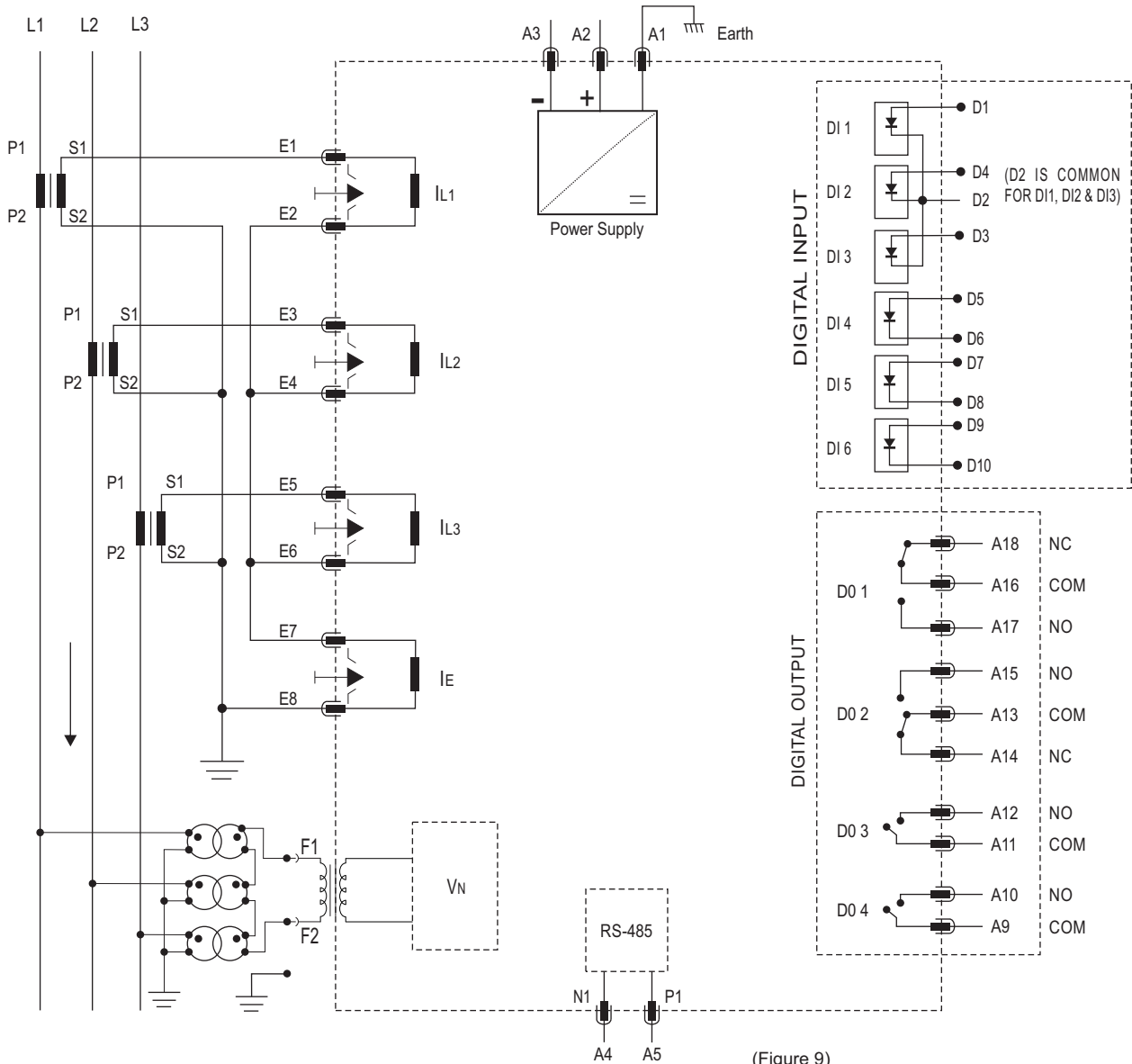

(Figure 9)

## Terminal Description

Terminal Name	Terminal Description
A1	: Auxiliary Supply Earth
A2-A3	: Auxiliary Supply
A4-A5	: RS-485 Modbus N1(A4), P1(A5)
A9-A10	: Potential free Digital Output 4
A11-A12	: Potential free Digital Output 3
A13-A14-A15	: Potential free Digital Output 2
A16 -A17- A18	: Potential free Digital Output 1
D1-D2	: Potential Digital Input 1
D4-D2	: Potential Digital Input 2
D3-D2	: Potential Digital Input 3
D5-D6	: Potential Digital Input 4
D7-D8	: Potential Digital Input 5
D9-D10	: Potential Digital Input 6
E1-E6	: CT Terminal for Phase current input L1(E1-E2), L2(E3-E4),L3(E5-E6)
E7-E8	: CT Terminal for Earth current input
F1-F2	: PT Terminals

## Trip Circuit Supervision

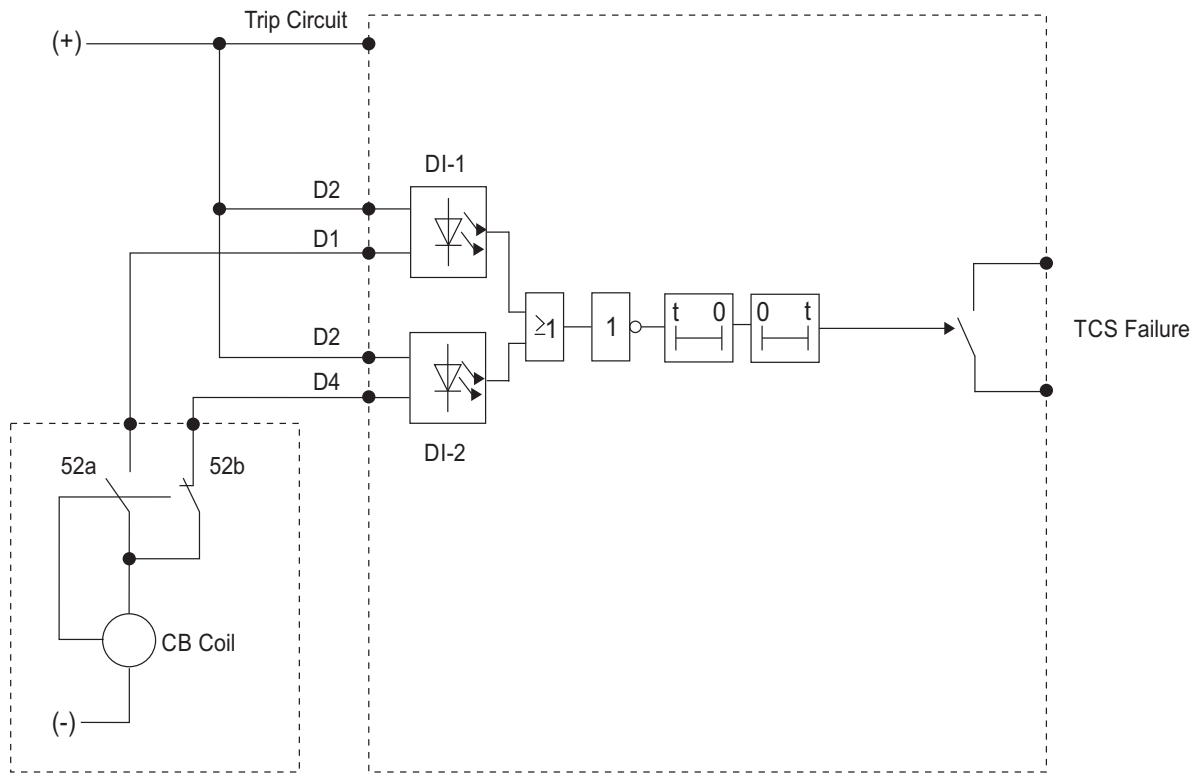

(Figure 10)

(Note: CB coil resistance should be such that at least 4mA current must flow in each Digital Input)

## 17) Back View of the Relay

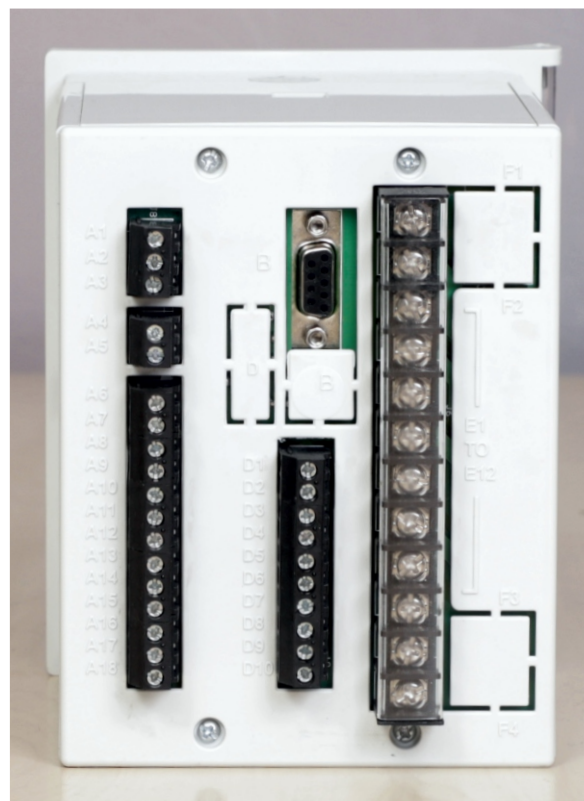

## 18) Dimensional Details

### Front View

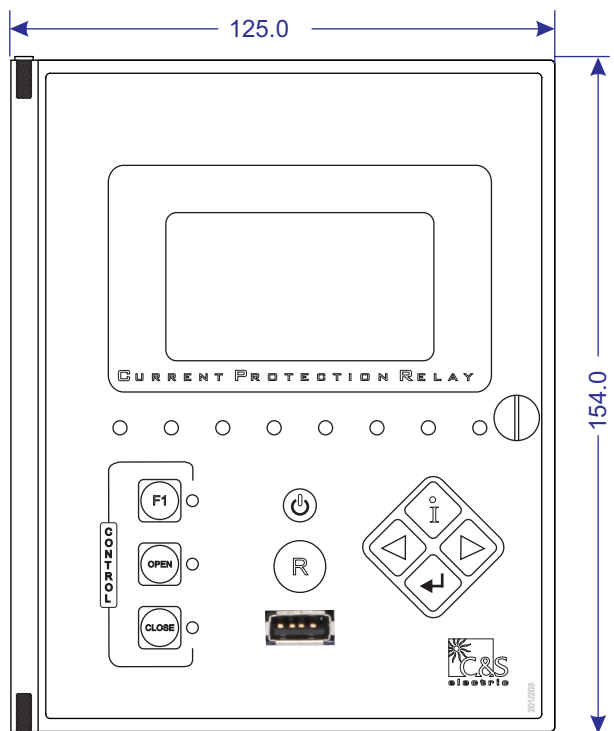

(Figure 12)

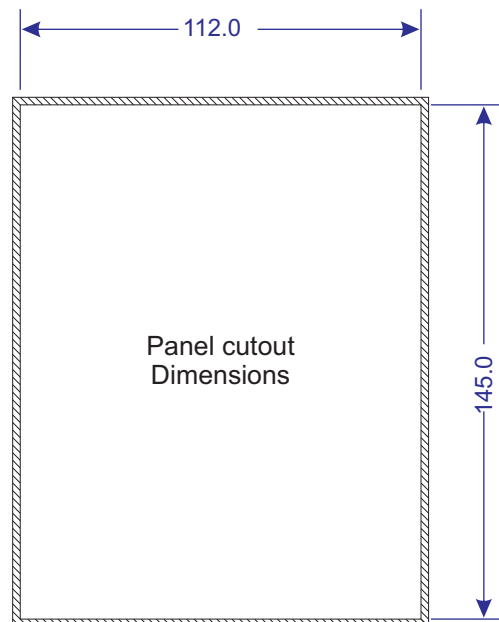

(Figure 13)

### Side View

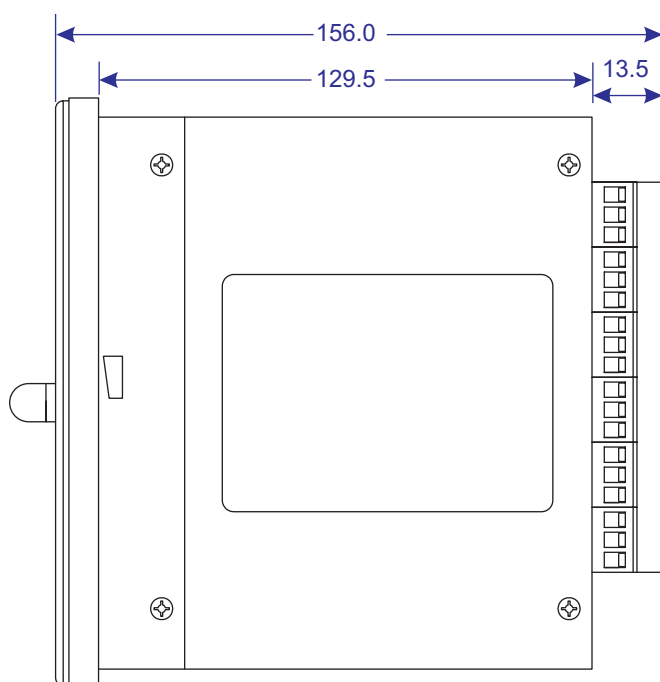

(Figure 14)

## 19) Ordering Information

