

We touch your **electricity** everyday!

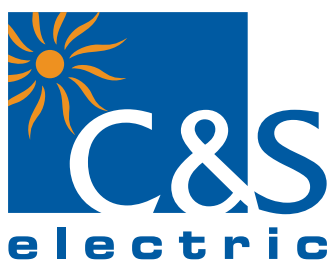

UL cUL SP CCC CE RoHS Compliant



Contactors



robusta
Power Contactors

Safety First

- Finger Safe IEC rated IP 20 Terminals
- Power & Control Terminals Touch-Safe

Compact Modular Design

- Design Flexibility
- Space Saving

Auxiliary Contact In-built

- Stocking & Specifying Made Easy

Low Power Consumption Coils

- Energy Saving
- Down Sizing of Control Transformer

Installation Made Easy

- DIN Rail Mounting or Screw Mount
- Assembly Time & Labour Saving

Protective Security Cover

- Prevents Accidental Manual Operation
- Prevents Dust Entry

It's all about...

Life & Performance



TC robusTa Contactor is manifestation of understanding discerning customer's requirements and applications. As the name suggests, robusTa Contactor are built for high performance assuring designs flexibility, safety and cost effective solutions.

robusTa Contactor are manufactured in our State-of-the-Art fully integrated ISO 90001 Certified manufacturing facility possessing comprehensive infrastructure inclusive of design, tooling, component manufacturing, assembling and testing to ensure World Class Products.

robusTa Contactors are user friendly, highly reliable & its modular design affords product selection with cost effective solutions.

robusTa Contactor & Overload Relay meets latest IEC, UL, CSA & CE Standards possessing Global accreditation. They conform to IEC60947-4-1.

robusTa Contactor starting solutions advantages

- World Class Superior functional aesthetics
- Complete & harmonized Contactor range
 - Contactor with AC3 rating 9~860A, AC/DC
 - Contactor with AC1 rating 25~2600A, AC/DC
- Safety first - Power & Control terminals are finger touch proof
- Energy Saving magnet coils in both AC & DC variants
- Compact Modular design for flexibility
- Saves inventory cost - Common Add-On Accessories
- High Mechanical & Electrical life
- Short Circuit Protection, Type -1 & 2 Co-ordination

Industrial Applications

- Motor Controls
- Pumps
- Machine Tools
- Printing & Packaging Machines
- Compressors
- Power Supply Solutions
- HVAC
- Cranes
- Elevator & Escalators
- Wind Mills
- Solar System

robusta Contactor Series



Conforming to IEC60947-4-1 VDE 0106
BS 5424; NFC 63-110

robustTa2

Code TC1D		711	911	1211	1811	2511	3211	3811	Control Relay
Maximum rated operational voltage		690	690	690	690	690	690	690	690
Maximum insulation voltage (Ui)	V	1000	1000	1000	1000	1000	1000	1000	1000
Maximum rated current for motor control	A	7	9	12	18	25	32	38	
Maximum Standard power rating (AC 3, 415V)	Kw	2.2	4	5.5	9	11	15	18.5	
	240V HP	2	3	3	7.5	7.5	10	10	
	460/480V HP	3	5	10	10	15	20	20	
	575/600V HP	5	7.5	10	15	20	25	25	
Mounting position (w.r.t. normal vertical mounting plane)*		+30°	+30°	+30°	+30°	+30°	+30°	+30°	+30°
Maximum Thermal current Ith (AC1)	A	25	25	25	32	40	50	50	10
Maximum operating rate (operations / hr.)	AC	3600	3600	3600	3600	3600	3600	3600	3600
	DC	-	-	-	-	-	-	-	3600
Average coil consumption (VA)	50 Hz	60/7	60/7	60/7	60/7	90/7.5	90/7.5	200/20	60/7
(inrush / sealed) at 20o C & at Uc	60 Hz	60/7.5	60/7.5	60/7.5	60/7.5	90/8.5	90/8.5	200/22	60/7.5
	50/60 Hz	70	70	70	70	100	100	245	70/8
	DC	-	-	-	-	-	-	-	9/9W
Heat dissipation at	50 and 60 Hz	2~3W	2~3W	2~3W	2~3W	2.5~3.5W	2.5~3.5W	6~10W	2~3W
	DC	-	-	-	-	-	-	-	9W
Mechanical life (in millions of operations)	50 or 60 Hz	15	15	15	15	15	15	15	30
	50/60 Hz	15	15	15	15	15	15	15	20
Power contact terminal capacity	mm²	0.75/10	0.75/10	0.75/10	0.75/10	0.75/16	0.75/16	0.75/16	
Over all dimensions in mm	AC/DC								

Accessories

Coil Suppressor
TAD4VN



Auxiliary Contact Block
(Side mounted) **TA8-DN**



NO	NC	
1	1	TA8-DN11
2	0	TA8-DN20

Auxiliary Contact Block
(Front mounted) **TA1-DN**



NO	NC	
0	1	TA1-DN01
1	0	TA1-DN10
1	1	TA1-DN11
0	2	TA1-DN02
2	0	TA1-DN20
4	0	TA1-DN40
3	1	TA1-DN31
2	2	TA1-DN22
1	3	TA1-DN13
0	4	TA1-DN04



robustA

09**	12**	18**	22**	25**	32**	38**	4011	4511	5011	6511	7011	8011	9511	115	150
690	690	690	690	690	690	690	690	690	690	690	690	690	690	1000	1000
1000	1000	1000	1000	1000	1000	1000	1000	1000	1000	1000	1000	1000	1000	1000	1000
9	12	18	22	25	32	38	40	45	50	65	70	80	95	115	150
4	5.5	9	11	11	15	18.5	22	25	25	37	37	45	45	55	75
2	3	5	5	7.5	10	10	10	20	15	20	25	25	25	40	54
5	7.5	10	10	15	20	20	30	40	40	50	40	60	60	73	101
7.5	10	15	15	20	25	25	30	45	40	50	45	60	60	107	134
+30°	+30°	+30°	+30°	+30°	+30°	+30°	+30°	+30°	+30°	+30°	+30°	+30°	+30°	+30°	+30°
25	25	32	32	40	50	50	60	80	80	80	100	125	125	250	250
3600	3600	3600	3600	3600	3600	3600	3600	3600	3600	3600	3600	3600	3600	2400	12 00
3600	3600	3600	3600	3600	3600	3600	3600	-	3600	3600	-	3600	-	300	1200
60/7	60/7	60/7	60/7	90/7.5	90/7.5	90/7.5	200/20	200/20	200/20	200/20	200/20	200/20	200/20	-	-
60/7.5	60/7.5	60/7.5	60/7.5	90/8.5	90/8.5	90/8.5	200/22	200/22	200/22	200/22	200/22	200/22	200/22	-	-
70/8	70/8	70/8	70/8	100/8.5	100/8.5	100/8.5	245/26	245/26	245/26	245/26	245/26	245/26	245/26	-	-
9/9W	9/9W	9/9W	9/9W	11/11W	11/11W	11/11W	22/22W	22/22W	22/22W	22/22W	22/22W	22/22W	22/22W	-	-
2~3W	2~3W	2~3W	2~3W	2.5~3.5W	2.5~3.5W	2.5~3.5W	6~10W	6~10W	6~10W	6~10W	6~10W	6~10W	6~10W	2~18W	2~18W
9W	9W	9W	9W	11W	11W	11W	22W	22W	22W	22W	22W	22W	-	-	-
20	20	20	20	16	16	16	16	16	16	16	10	10	10	8	-
15	15	15	15	12	12	12	6	6	6	6	4	4	4	-	-
1/4	1/4	1.5/6	1.5/6	1.5/10	2.5/10	2.5/10	2.5/25	2.5/25	4/50	4/50	4/50	4/50	4/50		

Note: 1) Replace** with 01 if required with 1NC aux., with 10 if required with 1NO aux.,2)

Timer Block → On Delay → Star Delta → Off Delay

Latch Add-on Block (Front mounted) LA6-DK01

Mechanical Interlock LA9D09978



0.1~3s TA2-DT0
0.1~30s TA2-DT2
0.1~180s TA2-DT4

1~30s TA2-DS2

0.1~3s TA3-DR0
0.1~30s TA3-DR2
0.1~180s TA3-DR4



robusta Contactor Series



Conforming to IEC60947-4-1 VDE 0106
BS 5424; NFC 63-110

Code LC1FDP		115A	150A	185A	200A	225A	265A	300A	330A
Maximum rated operational voltage	Volt, As per IEC 60947	1000	1000	1000	1000	1000	1000	1000	1000
Maximum insulation voltage (Ui)	Volt, As per IEC 60947	1000	1000	1000	1000	1000	1000	1000	1000
Maximum rated current for motor control	A	115	150	185	200	225	265	300	330
Maximum Standard power rating (AC3, 415V)	Kw	59	80	100	110	110	140	110	180
	230V HP	40	50	60	60	65	75	75	100
	460/480V HP	75	100	125	125	130	150	150	200
	675/600V HP	100	125	150	150	155	200	200	250
Mounting position (w.r.t. normal vertical mounting plane)*		+30°	+30°	+30°	+30°	+30°	+30°	+30°	+30°
Maximum Thermal current Ith (AC1)	A	200	250	275	275	315	350	400	400
Maximum operating rate(operations / hr.)	AC	2400	2400	2400	2400	2400	2400	2400	2400
Average coil consumption (VA)	50 Hz	550/45	550/45	970/55	805/55	970/55	1200/95	700/10	1200/95
(inrush / sealed) at 20° C & at Uc	60 Hz	660/55	660/55	970/55	-	970/55	1445/110	-	1445/110
	50/60 Hz	-	-	-	-	-	-	-	1075/15
	DC	560/4.5	560/4.5	800/5	902/5.07	800/5	750/5	803/4.53	750/5
Mechanical life (in millions of operations)	(AC) 50 or 60 Hz	10	10	10	10	10	10	10	10
	50/60 Hz	-	-	-	-	-	-	-	10
Power contact terminal capacity	mm ²	95	120	150	150	185	240	240	2 X 150
Over all dimensions in mm	AC/DC								





robuTa

	400A	460A	500A	580A	630A	780A	800A	860A	1250	1400	1700	2100	2600
	1000	1000	1000	1000	1000	1000	1000	1000	1000	1000	1000	1000	1000
	1000	1000	1000	1000	1000	1000	1000	1000	1500	1500	1500	1500	1500
	400	460	500	580	630	780	800	860A	1260	1400	1700	2100	2600
	220	220	280	355	375	425	450	-	-	-	-	-	-
	125	125	200	-	300	-	-	-	-	-	-	-	-
	250	250	400	-	600	-	-	-	-	-	-	-	-
	300	300	500	-	800	-	-	-	-	-	-	-	-
	+30°	+30°	+30°	+30°	+30°	+30°	+30°	+30°	30°	30°	30°	30°	30°
	500	600	700	800	1000	1600	1000	1260	1260	1400	1700	2100	2600
	2400	2400	1200	1200	600	1200	1200	1200	1200	600	600	600	600
	1075/15	1100/18	1100/18	1650/22	1730/25	2400/53	1730/25	1650/22	NA	NA	NA	NA	NA
	1075/15	-	1100/18	-	1730/25	2400/53	1730/25	1650/22	NA	NA	NA	NA	NA
	1100/18	-	1650/22	-	1730/25	2400/53	1730/25	1650/22	1730/25	2500/37	2500/37	2500/37	2700/50.6
	1000/6	1220/8	1100/6	1920/12.5	1920/12.5	2500/55	1920/12.5	1650/9	1920/12.5	2200/10	2500/10	2500/10	2880/25
	10	10	10	5	5	5	5	5	5	0.5	0.5	0.5	0.5
	10	10	10	5	5	5	5	5	5	0.5	0.5	0.5	0.5
	2X240	2X240	2X60X5	2X60X5	2X60X5	2x60x5	2x60x5	2X50X10	2x50x10	2x100x5	3x100x5	4x100x5	3x100x10



robusta Contactor Series

Overload Relays



robusta2



robusta



robusta

Relay Reference	Relay setting range (A)	Standard power ratings of 3-Ph. Motors 50/60Hz, AC3					Back Up		Base Plate* reference
		220V	380V	415V	440V	660V	Fuse Rating		
		KW	KW	KW	KW	KW	aM (A)	g1 (A)	
TR2■09301	0.1 to 0.16	-	-	-	-	-	0.25	2	TA7D0964
TR2■09302	0.16 to 0.25	-	-	-	-	-	0.5	2	
TR2■09303	0.25 to 0.4	-	-	-	-	-	1	2	
TR2■09304	0.4 to 0.63	-	-	-	-	0.37	1	2	
TR2■09305	0.63 to 1	-	-	-	-	0.55	2	4	
TR2■09306	1 to 1.6	-	0.37	-	0.55	1.1	2	4	
TR2■093X6	1.25 to 2	-	0.55	0.75	0.75	1.3	4	6	
TR2■09307	1.6 to 2.5	0.37	0.75	1.1	1.1	1.5	4	6	
TR2■09308	2.5 to 4	0.75	1.5	1.5	1.5	3	6	10	
TR2■09310	4 to 6	1.1	2.2	2.2	2.2	4	8	16	
TR2■09312	5.5 to 8	1.5	3	3.7	3.7	5.5	12	20	
TR2■09314	7 to 10	2.2	4	4	4	7.5	12	20	
TR2■12316	9 to 13	3	5.5	5.5	5.5	10	16	25	
TR2■18321	12 to 18	4	7.5	9	9	15	20	35	
TR2■25322	17 to 25	5.5	11	11	11	18.5	25	50	TA7D3264
TR2■32353	23 to 32	7.5	15	15	15	-	40	63	
TR2■32355	28 to 36	9	15	18.5	18.5	-	40	80	
TR2■40355	30 to 40	10	18.5	22	22	30	40	100	TA7D4064
TR2■65357	37 to 50	11	22	25	25	37	63	100	
TR2■65359	48 to 65	18.5	25	30	30	50	63	100	
TR2■65361	55 to 70	20	30	37	37	55	80	125	
TR2■80363	63 to 80	22	33	40	40	59	80	125	
TR2■95365	80 to 93	25	45	49	50	80	100	160	
LR1-F105	65 to 105	25	51	55	59	90	0.25	160	
LR1-F125	80 to 125	30	59	59	63	110	125	200	
LR1-F160	100 to 160	45	80	80	90	140	160	250	
LR1-F200	125 to 200	55	90	100	110	160	200	315	
LR1-F250	160 to 250	63	110	129	140	200	250	400	
LR1-F315	200 to 315	80	150	160	160	257	315	500	
LR1-F400	250 to 400	110	185	200	220	335	400	630	
LR1-F500	315 to 500	140	250	257	280	445	500	800	
LR1-F630	400 to 630	180	315	355	375	500	630	800	
*LR1-F800	500 to 800	220	400	425	450	-	-	1000	
*LR1-F1000	630 to 1000	295	500	500	500	-	-	1250	

Note: Replace ■ with D for relays compatible with robusta or DM for relays compatible with robust 2 contactors.

Electrical Life Curve - TC1D Type

Use in Category AC-1 ($U_e \leq 440V$).

Control of resistive circuits ($\cos\phi > 0.95$). The current broken (I_c) in category AC-1 is equal to the current (I_n) normally drawn by the load.

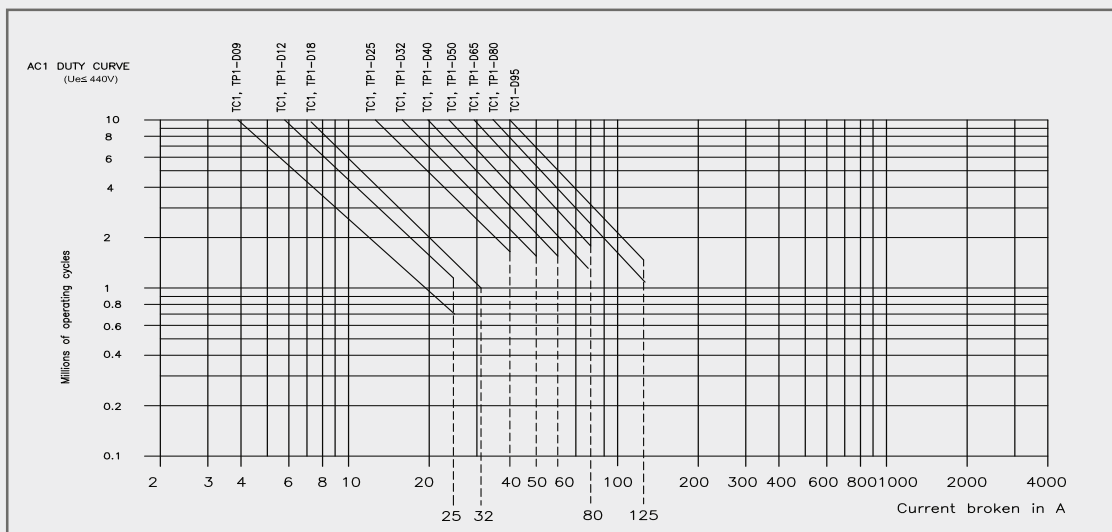

Use in Category AC-3 ($U_e \leq 440V$).

Control of 3-phase asynchronous squirrel cage motors with breaking whilst motor running. The current broken (I_c) in category AC-3 is equal to the current (I_n) normally drawn by the load.

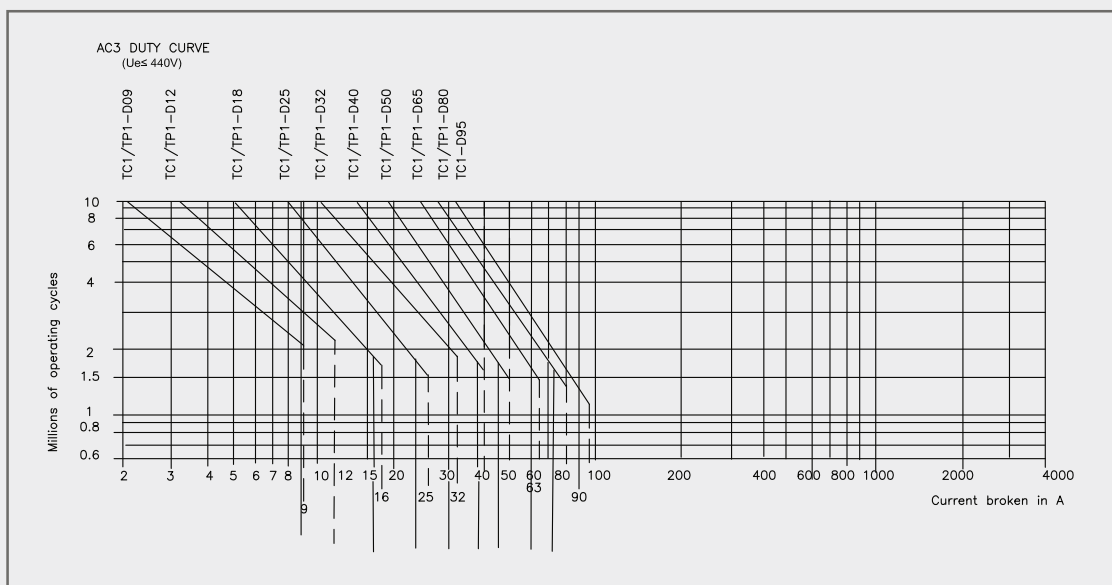

Use in Categories AC-2, AC-4 ($U_e \leq 440V$).

Control of 3-phase asynchronous squirrel cage (AC-4) or slip ring (AC-2) motors with breaking whilst motor stalled. The current broken in category AC-4 is equal to $6 \times I_n$. (I_n = rated operational current of the motor).

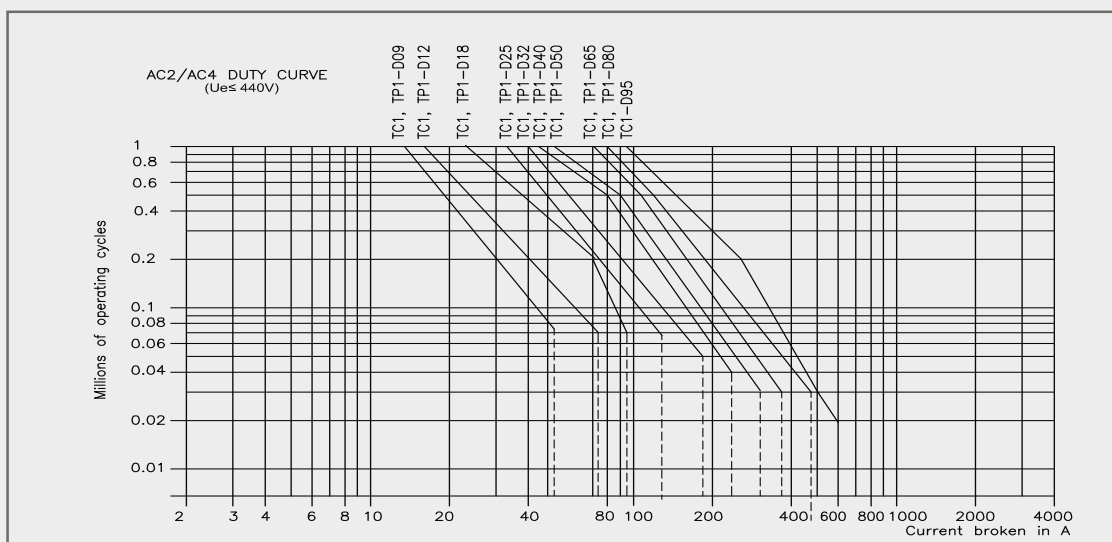

robusta Contactor Series

Electrical Life Curve - LC1FDP Type

Use in Category AC-1 ($U_e \leq 440V$).

Control of resistive circuits ($\cos\phi \geq 0.95$). The current broken (I_c) in category AC-1 is equal to the current (I_n) normally drawn by the load.

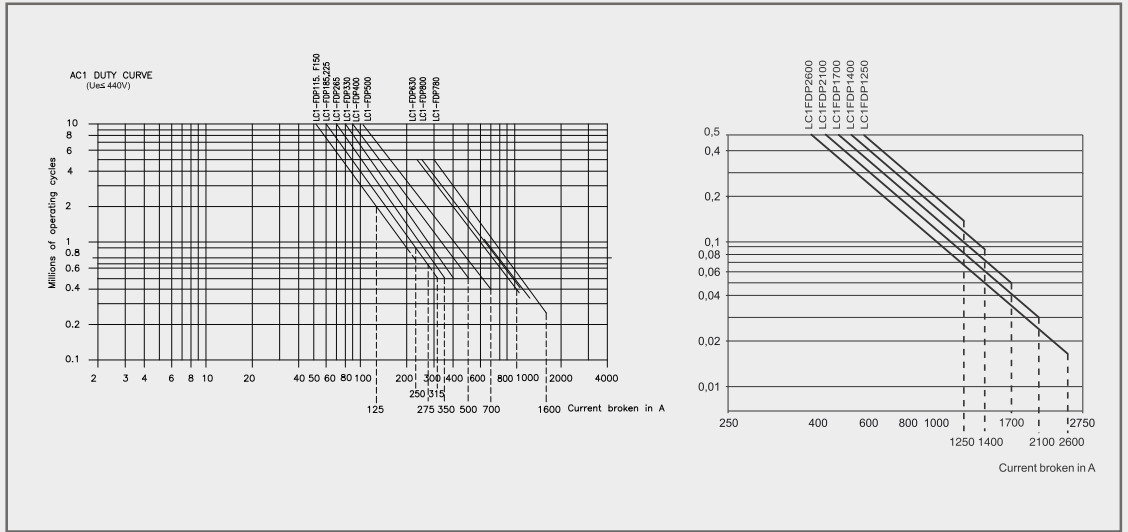

Use in Category AC-3 ($U_e \leq 440V$).

Control of 3-phase asynchronous squirrel cage motors with breaking whilst motor running. The current broken (I_c) in category AC-3 is equal to the current (I_n) normally drawn by the load.

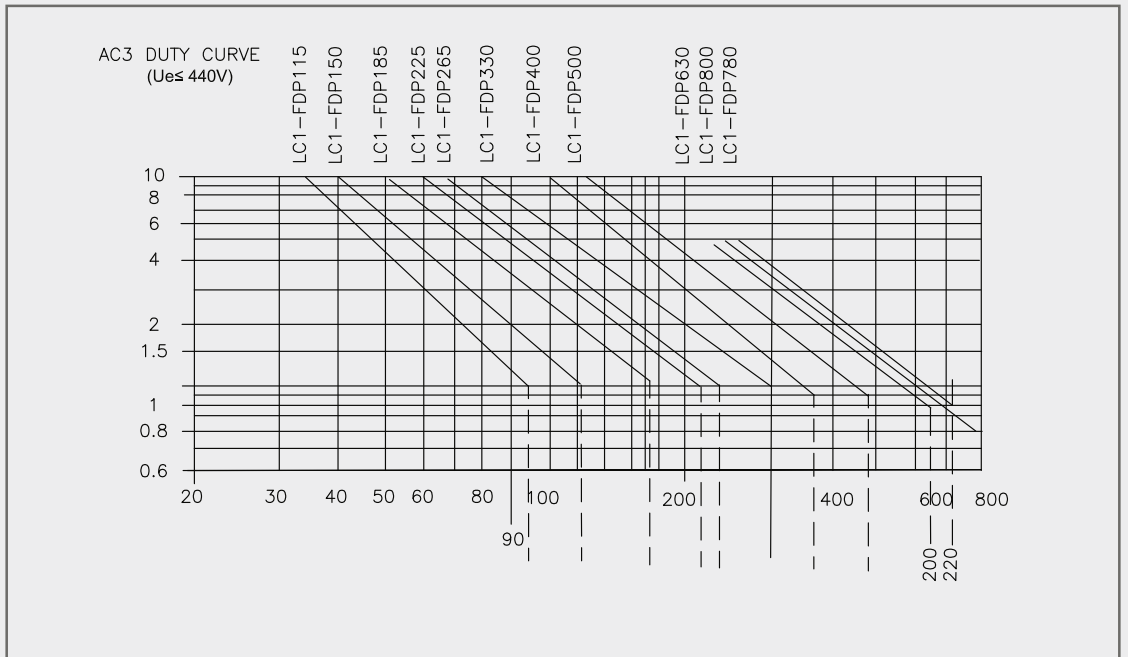

Use in Categories AC-2, AC-4 ($U_e \leq 440V$).

Control of 3-phase asynchronous squirrel cage (AC-4) or slip ring (AC-2) motors with breaking whilst motor stalled. The current broken in category AC-4 is equal to $6 \times I_n$ (I_n = rated operational current of the motor).

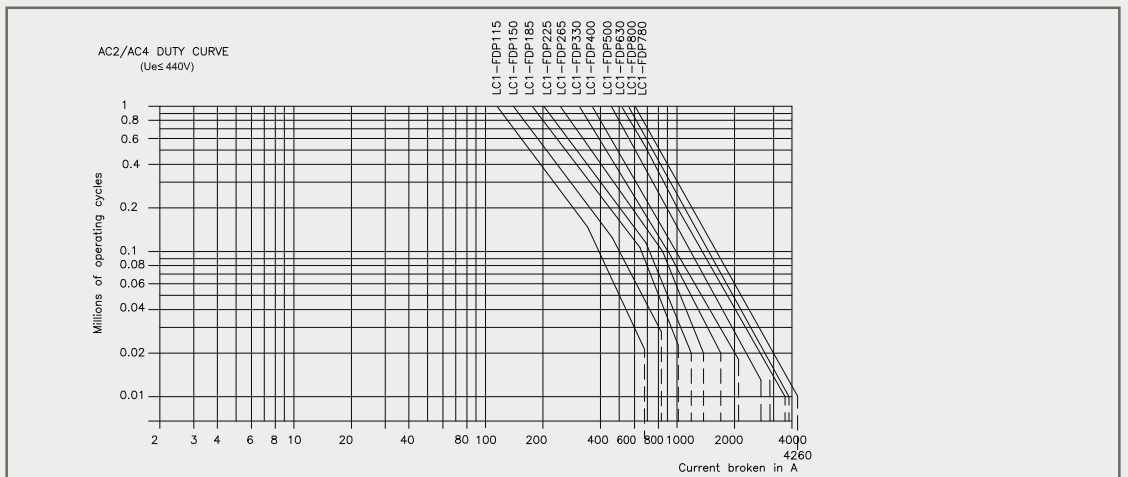

TP1D1210-R

Robusta T-Range Contactor - 3P (1 NO)

25 A - AC-1

12 A - AC-3

Main

Range	Robusta-R
Product name	T-Range
Product or component type	Contactors
Device short name	TP1D
Contactors application	Resistive load Motor Control
Utilisation category	AC-1 AC-3
Poles description	3P
Power pole contact composition	1 NO
[Ue] rated operational voltage	<= 690 V AC
[Ie] rated operational current	25A (at $\theta \leq 40^\circ\text{C}$) at <= 440 V AC-1 12A (at $\theta \leq 55^\circ\text{C}$) at <= 440 V AC-3
Motor power kW	3 kW at 220...230 V AC 50/60 Hz (AC-3) 5.5 kW at 380...400 V AC 50/60 Hz (AC-3) 5.5 kW at 415 V AC 50/60 Hz (AC-3) 5.5 kW at 440 V AC 50/60 Hz (AC-3) 7.5 kW at 500 V AC 50/60 Hz (AC-3) 7.5 kW at 660...690 V AC 50/60 Hz (AC-3)
[Uimp] rated impulse withstand voltage	6kV
[Ui] rated insulation voltage	1000 V conforming to IEC 60947-4-1
Overtoltage category	III
[Ith] conventional free air thermal current	25A (at $\theta \leq 40^\circ\text{C}$)
Irms rated making capacity	300A conforming to IEC 60947-4-1
Rated breaking capacity	300A at 220...440V conforming to IEC 60947-4-1 250A at 550V conforming to IEC 60947-4-1 120A at 660...690V conforming to IEC 60947-4-1
[Icw] rated short-time withstand current from cold state, no current flowing for preceding 15 minutes	240A at $\theta \leq 40^\circ\text{C}$ - 1 s for power circuit 185A at $\theta \leq 40^\circ\text{C}$ - 5 s for power circuit 145A at $\theta \leq 40^\circ\text{C}$ - 10 s for power circuit 105A at $\theta \leq 40^\circ\text{C}$ - 30 s for power circuit 84A at $\theta \leq 40^\circ\text{C}$ - 1 min for power circuit 58A at $\theta \leq 40^\circ\text{C}$ - 3 min for power circuit 40A at $\theta \leq 40^\circ\text{C}$ - 10 min for power circuit
Ambient air temperature for operation	-5...55°C
Ambient air temperature for storage	-25...70°C

Mechanical Robustness

Shock & Vibration resistance conforming to IEC 61373 :2010

Vibrations contactor open:

0.964 (m/s²)² /Hz V* axis b/w 5 Hz and 20 Hz,

0.912 (m/s²)² /Hz in T* axis b/w 5 Hz and 20 Hz,

0.461 (m/s²)² /Hz in L* axis b/w 5 Hz and 20Hz

Random type, 5 hours test

Vibrations contactor closed:

0.0301 (m/s²)² /Hz in V* axis b/w 5 Hz and 20 Hz,

0.0060 (m/s²)² /Hz in T* axis b/w 5 Hz and 20 Hz,

0.0144 (m/s²)² /Hz in L* axis b/w 5 Hz and 20 Hz

Random type, ten minute test

Shocks contactor open:

30m/s² in V* & T* axis,

50m/s² in L* axis Half sine type, 30 ms pulse

Material

EN 45545 HL2 compliant Class R22 for Railway Application

EN 45545 HL3 compliant Class R22 for Railway Application

Technical Data Sheet

Associated fuse rating	32A gG at ≤ 440 V
Average impedance per pole	2.5mOhm - lth 25A and 50 Hz for power circuit
[U _i] rated insulation voltage	1000V conforming to IEC 60947-4-1
Power dissipation per pole	1.56 W AC-1 0.36 W AC-3
Control circuit voltage limits	Operational: 0.85. 1.1 U _c Drop-out: 0.1. 0.75 U _c
Mounting support	Plate Rail
Standards	EN 60947-4-1, EN60947-1 IEC 60947-4-1, IEC 60947-1
Approvals	UL, CSA

Connections - terminals	Control circuit: screw clamp terminals 2 cable(s) 1...2.5mm ² flexible with cable end Control circuit: screw clamp terminals 1 cable(s) 1...4mm ² flexible with cable end Control circuit: screw clamp terminals 1 cable(s) 1...4mm ² flexible without cable end Control circuit: screw clamp terminals 2 cable(s) 1...4mm ² flexible without cable end Control circuit: screw clamp terminals 1 cable(s) 1...4mm ² solid without cable end Control circuit: screw clamp terminals 2 cable(s) 1...4mm ² solid without cable end Power circuit: connector 1 cable(s) 1...4mm ² flexible without cable end Power circuit: connector 2 cable(s) 1...4mm ² flexible without cable end Power circuit: connector 1 cable(s) 1...4 mm ² flexible with cable end Power circuit: connector 2 cable(s) 1...2.5mm ² flexible with cable end Power circuit: connector 1 cable(s) 1...4 mm ² solid without cable end Power circuit: connector 2 cable(s) 1...4 mm ² solid without cable end
Tightening torque	Power circuit: 1.2N.m
Maximum operating rate	3600cyc/h at $\theta \leq 55^{\circ}\text{C}$
Mechanical Durability (in millions of operating cycles)	30
Maximum operating altitude	3000 m without derating
Operating positions	$\pm 30^{\circ}$ possible, in relation to normal vertical mounting plane
IP degree of protection	IP 20 front face with shrouds conforming to IEC 60529
Height	74mm
Width	45mm
Depth	120mm

V* -- Vertical, T* -- Transverse, L* -- Longitudinal

- ❖ Coil inter- changeability with-in same frame will not affect any design change in contactor
- ❖ All type contactor (s) are suitable to work in temperature range -5°C to 70°C & relative humidity up to 98 %

Dimensions:

Product Dimensions TP1-D09-D3810

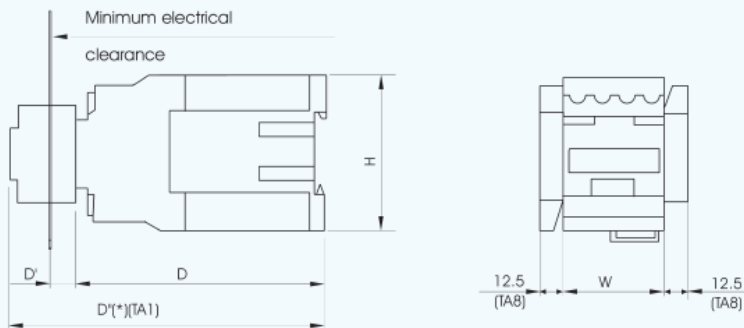

TP1-D4011-D80

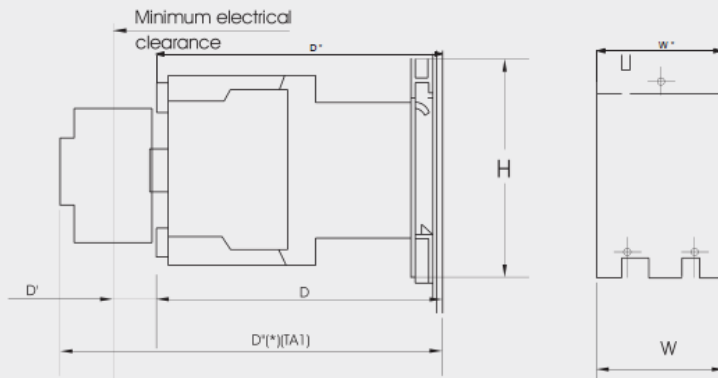

TP1 -	D09	D12	D18	D22	D25	D32	D38	D40	D50	D65	D80
W (3 Pole)	45	45	45	45	56	56	56	75	75	75	85
W* (4 Pole)	45	45	-	-	56	-	-	85	85	85	96
H (3/4 Pole)	74	74	74	74	84	84	84	127	127	127	127
D (3/4 Pole)	115	115	120	120	130	135	135	171	171	171	181
D' (3/4 Pole)	10	10	10	10	10	10	10	12	12	12	12
D*(*) (3/4 Pole)	148	148	153	153	163	168	168	202	202	202	210
D*(008)	-	-	-	-	-	-	-	181	181	181	191

TP1D1801-R

Robusta T-Range Contactor - 3P (1 NC)

32 A - AC-1

18 A - AC-3

Main

Range	Robusta-R
Product name	T-Range
Product or component type	Contacteur
Device short name	TP1D
Contacteur application	Resistive load Motor Control
Utilisation category	AC-1 AC-3
Poles description	3P
Power pole contact composition	1 NC
[Ue] rated operational voltage	<= 690 V AC
[Ie] rated operational current	32A (at $\theta \leq 40^{\circ}\text{C}$) at <= 440 V AC-1 18A (at $\theta \leq 55^{\circ}\text{C}$) at <= 440 V AC-3
Motor power kW	4 kW at 220...230 V AC 50/60 Hz (AC-3) 7.5 kW at 380...400 V AC 50/60 Hz (AC-3) 9 kW at 415 V AC 50/60 Hz (AC-3) 9 kW at 440 V AC 50/60 Hz (AC-3) 10 kW at 500 V AC 50/60 Hz (AC-3) 10 kW at 660...690 V AC 50/60 Hz (AC-3)
[Uimp] rated impulse withstand voltage	6kV
[Ui] rated insulation voltage	1000 V conforming to IEC 60947-4-1
Overvoltage category	III
[I _{th}] conventional free air thermal current	32A (at $\theta \leq 40^{\circ}\text{C}$)
I _{rms} rated making capacity	300A conforming to IEC 60947-4-1
Rated breaking capacity	300A at 220...440V conforming to IEC 60947-4-1 250A at 550V conforming to IEC 60947-4-1 120A at 660...690V conforming to IEC 60947-4-1
[I _{cw}] rated short-time withstand current from cold state, no current flowing for preceding 15 minutes	240A at $\theta \leq 40^{\circ}\text{C}$ - 1 s for power circuit 185A at $\theta \leq 40^{\circ}\text{C}$ - 5 s for power circuit 145A at $\theta \leq 40^{\circ}\text{C}$ - 10 s for power circuit 105A at $\theta \leq 40^{\circ}\text{C}$ - 30 s for power circuit 84A at $\theta \leq 40^{\circ}\text{C}$ - 1 min for power circuit 58A at $\theta \leq 40^{\circ}\text{C}$ - 3 min for power circuit 40A at $\theta \leq 40^{\circ}\text{C}$ - 10 min for power circuit
Ambient air temperature for operation	-5...55°C
Ambient air temperature for storage	-25...70°C

Mechanical Robustness	Shock & Vibration resistance conforming to IEC 61373 :2010 Vibrations contacteur open: 0.964 (m/s ²) ² /Hz V* axis b/w 5 Hz and 20 Hz, 0.912 (m/s ²) ² /Hz in T* axis b/w 5 Hz and 20 Hz, 0.461 (m/s ²) ² /Hz in L* axis b/w 5 Hz and 20Hz Random type, 5 hours test Vibrations contacteur closed: 0.0301 (m/s ²) ² /Hz in V* axis b/w 5 Hz and 20 Hz, 0.0060 (m/s ²) ² /Hz in T* axis b/w 5 Hz and 20 Hz, 0.0144 (m/s ²) ² /Hz in L* axis b/w 5 Hz and 20 Hz Random type, ten minute test Shocks contacteur open: 30m/s ² in V* & T* axis, 50m/s ² in L* axis Half sine type, 30 ms pulse
-----------------------	--

Material	EN 45545 HL2 compliant Class R22 for Railway Application EN 45545 HL3 compliant Class R22 for Railway Application
----------	--

Associated fuse rating	32A gG at ≤ 440 V
Average impedance per pole	2.5mOhm - lth 25A and 50 Hz for power circuit
[U _i] rated insulation voltage	1000V conforming to IEC 60947-4-1
Power dissipation per pole	2.5W AC-1 0.8 W AC-3
Control circuit voltage limits	Operational: 0.85. 1.1 U _c Drop-out: 0.1. 0.75 U _c
Mounting support	Plate Rail
Standards	EN 60947-4-1, EN60947-1 IEC 60947-4-1, IEC60947-1
Approvals	UL, CSA

Technical Data Sheet

Connections - terminals

Control circuit: screw clamp terminals 2 cable(s) 1...2.5mm² flexible with cable end
 Control circuit: screw clamp terminals 1 cable(s) 1...4mm² flexible with cable end
 Control circuit: screw clamp terminals 1 cable(s) 1...4mm² flexible without cable end
 Control circuit: screw clamp terminals 2 cable(s) 1...4mm² flexible without cable end
 Control circuit: screw clamp terminals 1 cable(s) 1...4mm² solid without cable end
 Control circuit: screw clamp terminals 2 cable(s) 1...4mm² solid without cable end
 Power circuit: connector 1 cable(s) 1.5...6mm² flexible without cable end
 Power circuit: connector 2 cable(s) 1.5...6mm² flexible without cable end
 Power circuit: connector 1 cable(s) 1...6 mm² flexible with cable end
 Power circuit: connector 2 cable(s) 1...4mm² flexible with cable end
 Power circuit: connector 1 cable(s) 1.5... 6 mm² solid without cable end
 Power circuit: connector 2 cable(s) 1.5... 6 mm² solid without cable end

Tightening torque	Power circuit: 1.7N.m
Maximum operating rate	3600cyc/h at $\theta \leq 55^{\circ}\text{C}$
Mechanical Durability (in millions of operating cycles)	30
Maximum operating altitude	3000 m without derating
Operating positions	$\pm 30^{\circ}$ possible, in relation to normal vertical mounting plane
IP degree of protection	IP 20 front face with shrouds conforming to IEC 60529
Height	74mm
Width	45mm
Depth	120mm

V* -- Vertical, T* -- Transverse, L* -- Longitudinal

- ❖ Coil inter- changeability with-in same frame will not affect any design change in contactor
- ❖ All type contactor (s) are suitable to work in temperature range -5°C to 70°C & relative humidity up to 98 %

Dimensions:

Product Dimensions TP1-D09~D3810

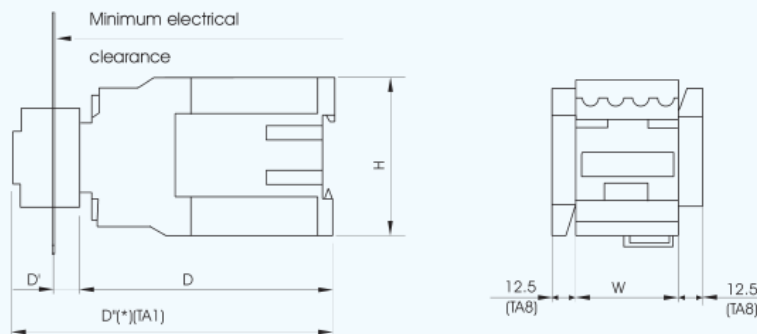

TP1-D4011~D80

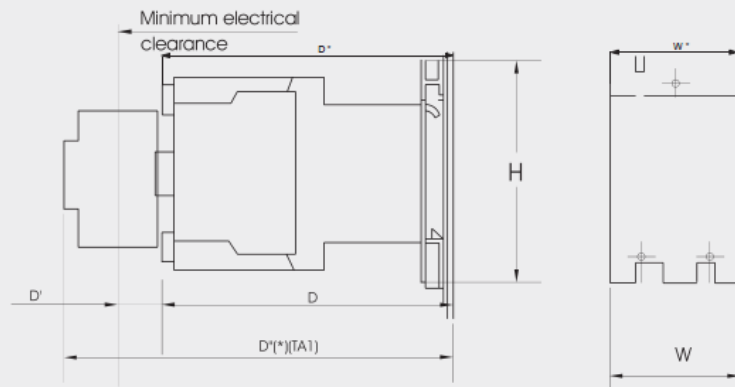

TP1 -	D09	D12	D18	D22	D25	D32	D38	D40	D50	D65	D80
W (3 Pole)	45	45	45	45	56	56	56	75	75	75	85
W* (4 Pole)	45	45	-	-	56	-	-	85	85	85	96
H (3/4 Pole)	74	74	74	74	84	84	84	127	127	127	127
D (3/4 Pole)	115	115	120	120	130	135	135	171	171	171	181
D' (3/4 Pole)	10	10	10	10	10	10	10	12	12	12	12
D* (3/4 Pole)	148	148	153	153	163	168	168	202	202	202	210
D*(008)	-	-	-	-	-	-	-	181	181	181	191

TP1D3201-R

Robusta T-Range Contactor - 3P (1 NC)

50 A - AC-1

32 A - AC-3

Main

Range	Robusta-R
Product name	T-Range
Product or component type	Contacteur
Device short name	TP1D
Contacteur application	Resistive load Motor Control
Utilisation category	AC-1 AC-3
Poles description	3P
Power pole contact composition	1 NC
[Ue] rated operational voltage	<= 690 V AC
[Ie] rated operational current	50A (at $\theta \leq 40^{\circ}\text{C}$) at <= 440 V AC-1 32A (at $\theta \leq 55^{\circ}\text{C}$) at <= 440 V AC-3
Motor power kW	7.5kW at 220...230V AC 50/60Hz (AC-3) 15kW at 380...400 V AC 50/60 Hz (AC-3) 15 kW at 415 V AC 50/60 Hz (AC-3) 15 kW at 440 V AC 50/60 Hz (AC-3) 18.5 kW at 500 V AC 50/60 Hz (AC-3) 18.5kW at 660..690V AC 50/60Hz (AC-3)
[Uimp] rated impulse withstand voltage	8kV
[Ui] rated insulation voltage	1000 V conforming to IEC 60947-4-1
Overvoltage category	III
[Ith] conventional free air thermal current	50A (at $\theta \leq 40^{\circ}\text{C}$)
Irms rated making capacity	550A conforming to IEC 60947-4-1
Rated breaking capacity	550A at 220...440V conforming to IEC 60947-4-1 450A at 550V conforming to IEC 60947-4-1 180A at 660...690V conforming to IEC 60947-4-1
[Icw] rated short-time withstand current from cold state, no current flowing for preceding 15 minutes	430A at $\theta \leq 40^{\circ}\text{C}$ - 1 s for power circuit 340A at $\theta \leq 40^{\circ}\text{C}$ - 5 s for power circuit 260A at $\theta \leq 40^{\circ}\text{C}$ - 10 s for power circuit 175A at $\theta \leq 40^{\circ}\text{C}$ - 30 s for power circuit 138A at $\theta \leq 40^{\circ}\text{C}$ - 1 min for power circuit 92A at $\theta \leq 40^{\circ}\text{C}$ - 3 min for power circuit 60A at $\theta \leq 40^{\circ}\text{C}$ - 10 min for power circuit
Ambient air temperature for operation	-5...55°C
Ambient air temperature for storage	-25...70°C

Mechanical robustness	Shock & Vibration resistance conforming to IEC 61373 :2010 Vibrations contacteur open: 0.964 (m/s ²) ² /Hz V* axis b/w 5 Hz and 20 Hz, 0.912 (m/s ²) ² /Hz in T* axis b/w 5 Hz and 20 Hz, 0.461 (m/s ²) ² /Hz in L* axis b/w 5 Hz and 20Hz Random type, 5 hours test Vibrations contacteur closed: 0.0301 (m/s ²) ² /Hz in V* axis b/w 5 Hz and 20 Hz, 0.0060 (m/s ²) ² /Hz in T* axis b/w 5 Hz and 20 Hz, 0.0144 (m/s ²) ² /Hz in L* axis b/w 5 Hz and 20 Hz Random type, ten minute test Shocks contacteur open: 30m/s ² in V* & T* axis, 50 m/s ² in L* axis Half sine type, 30 ms pulse
-----------------------	--

Technical Data Sheet

Material	EN 45545 HL2 compliant Class R22 for Railway Application EN 45545 HL3 compliant Class R22 for Railway Application
----------	--

Associated fuse rating	50A gG at ≤ 440 V
------------------------	------------------------

Average impedance per pole	2mOhm - lth 25A and 50 Hz for power circuit
----------------------------	---

[Ui] rated insulation voltage	1000V conforming to IEC 60947-4-1
-------------------------------	-----------------------------------

Power dissipation per pole	5 W AC-1 2 W AC-3
----------------------------	----------------------

Control circuit voltage limits	Operational: 0.85. 1.1 Uc Drop-out: 0.1. 0.75 Uc
--------------------------------	---

Mounting support	Plate Rail
------------------	---------------

Standards	EN 60947-4-1 IEC 60947-4-1 EN 60947-1 IEC 60947-1
-----------	--

Approvals	UL, CSA
-----------	---------

Connections - terminals	Control circuit: screw clamp terminals 2 cable(s) 1...2.5mm ² flexible with cable end Control circuit: screw clamp terminals 1 cable(s) 1...4mm ² flexible with cable end Control circuit: screw clamp terminals 1 cable(s) 1...4mm ² flexible without cable end Control circuit: screw clamp terminals 2 cable(s) 1...4mm ² flexible without cable end Control circuit: screw clamp terminals 1 cable(s) 1...4mm ² solid without cable end Control circuit: screw clamp terminals 2 cable(s) 1...4mm ² solid without cable end Power circuit: connector 1 cable(s) 2.5...10mm ² flexible without cable end Power circuit: connector 2 cable(s) 2.5...10mm ² flexible without cable end Power circuit: connector 1 cable(s) 1...10 mm ² flexible with cable end Power circuit: connector 2 cable(s) 1.5...6mm ² flexible with cable end Power circuit: connector 1 cable(s) 1.5... 10 mm ² solid without cable end Power circuit: connector 2 cable(s) 2.5... 10 mm ² solid without cable end
Tightening torque	Power circuit: 2.5N.m
Maximum operating rate	3600cyc/h at $\theta \leq 55^{\circ}\text{C}$
Mechanical Durability (in millions of operating cycles)	25
Maximum operating altitude	3000 m without derating
Operating positions	$\pm 30^{\circ}$ possible, in relation to normal vertical mounting plane
IP degree of protection	IP 20 front face with shrouds conforming to IEC 60529
Height	84mm
Width	56mm
Depth	135mm

V* -- Vertical, T* -- Transverse, L* -- Longitudinal

- ❖ Coil inter- changeability with-in same frame will not affect any design change in contactor
- ❖ All type contactor (s) are suitable to work in temperature range -5°C to 70°C & relative humidity up to 98 %

Dimensions:

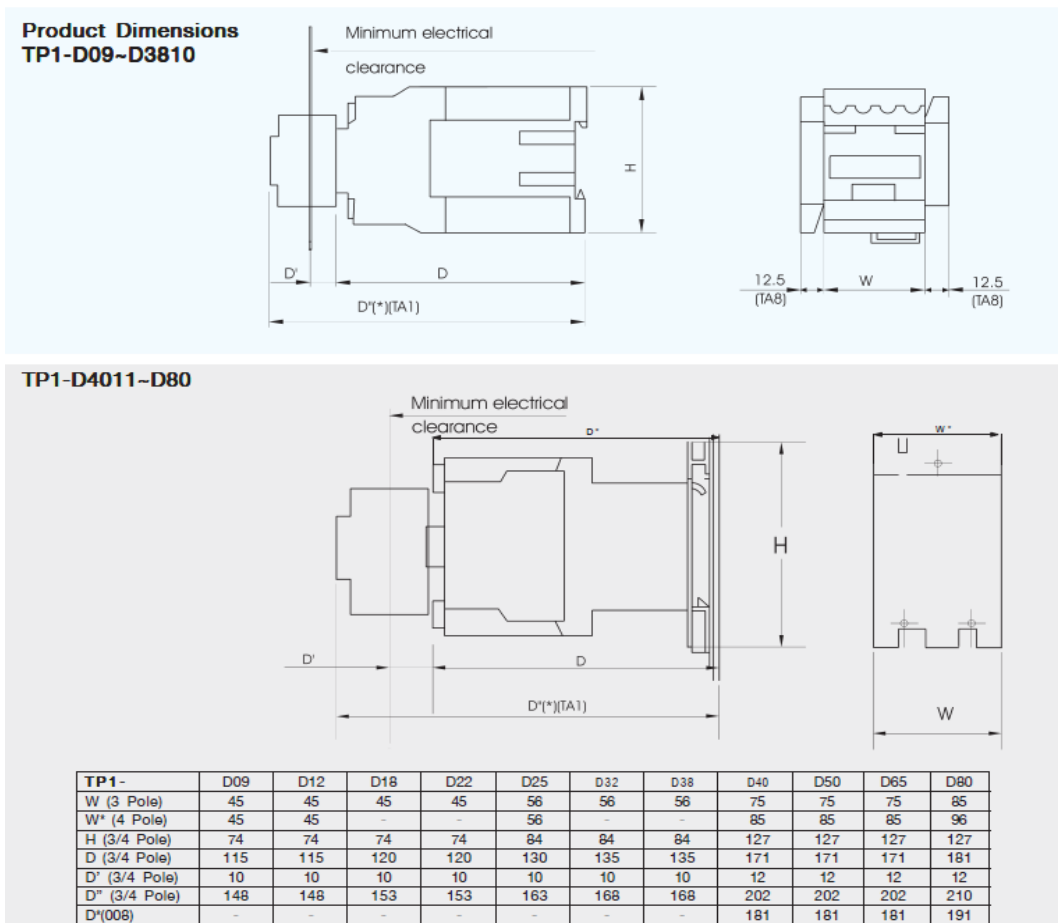

TP1D95008-R

Contactora 4P

Main

Product or component type	Contactora
Device short name	TP1D
Contactora application	Motor Control Resistive load
Utilisation category	AC-3 AC-1
Poles description	4P
Power pole contact composition	2 NO + 2 NC
[Ue] rated operational voltage	≤1000 V AC 25.....400Hz for power circuit
[Ie] rated operational current	95A (θ ≤ 55 °C) AC-3 for power circuit ≤ 440 V 125A (θ ≤ 40 °C) AC-1 for power circuit ≤ 440 V
Motor power kW	45 kW at 415 V 45 kW at 440 V 45 kW at 500 V 25 kW at 220...230 V AC 50/60 Hz 45 kW at 380...400 V 55 kW at 660...690 V
[Uimp] rated impulse withstand voltage	8 kV conforming to IEC 60947-4-1
Overvoltage category	III
Frequency Limits	25...400Hz
Irms rated making capacity	1200 A at 440 V for power circuit conforming to IEC 60947-4-1
Rated breaking capacity	1100 A at 440 V for power circuit conforming to IEC 60947-4-1 1100 A at 500 V for power circuit conforming to IEC 60947-4-1 640 A at 660-690 V for power circuit conforming to IEC 60947-4-1
Permissible short-time rating from cold state, no current flowing for preceding 15 minutes at θ ≤ 40 °C	135 A - 600 s for power circuit 320 A - 60 s for power circuit 640 A - 10s for power circuit
Associated fuse rating	125A gG at ≤ 440V
Average impedance	0.8 mOhm at 50 Hz Ith 95 A for power circuit
[Ui] rated insulation voltage	1000 V conforming to IEC 60947-4-1
Electrical durability in million of operating cycles	1.2 AC-3 95A at Ue ≤ 440V 1.6 AC-1 125A at Ue ≤ 440V
Power dissipation per pole	12.5 W AC-1 7.2 W AC-3
Tightening torque	9 N.m for power circuit
Mounting support	DIN rail Plate
Standards	IEC 60947-1 IEC 60947-4-1 BS EN 60947-4-1
Approvals	UL, CSA, CCC

Connections - terminals	Power circuit : screw clamp terminals - 2 flexible cable(s) 4...16 mm ² with cable end Power circuit : screw clamp terminals - 1 flexible cable(s) 4...50 mm ² with cable end Power circuit : screw clamp terminals - 2 solid cable(s) 4...25 mm ² without cable end Power circuit : screw clamp terminals - 1 solid cable(s) 4...50 mm ² without cable end Power circuit : screw clamp terminals - 2 flexible cable (s) 4...25 mm ² without cable end Power circuit : screw clamp terminals - 1 flexible cable (s) 4...50 mm ² without cable end Control circuit : screw clamp terminals - 2 solid cable(s) 1...4 mm ² without cable end Control circuit : screw clamp terminals - 1 solid cable(s) 1...4 mm ² without cable end Control circuit : screw clamp terminals - 2 flexible cable(s) 1...2.5 mm ² with cable end Control circuit : screw clamp terminals - 1 flexible cable(s) 1...4 mm ² with cable end Control circuit : screw clamp terminals - 2 flexible cable(s) 1...4 mm ² without cable end Control circuit : screw clamp terminals - 1 flexible cable(s) 1...4 mm ² without cable end
Tightening torque	1.7 N.m for control circuit
Mechanical durability in million of operating cycles	20
Maximum Operating rate	3600 cycles per hour at $\theta \leq 55^\circ\text{C}$
[Uc] Control circuit voltage *	24,48,110,220,230,235,240,415 V
Control circuit voltage limits	0.1...0.4 Uc at $\theta \leq 55^\circ\text{C}$ drop-out 0.85...1.1 Uc at $\theta \leq 55^\circ\text{C}$ operational
Average consumption at 20 °C	Inrush 22 ± 3 W at 20 °C Sealed 22 ± 3 W at 20 °C
IP degree of protection	IP2X conforming to IEC 60529
Ambient air temperature around the device	Storage -60...+80 °C Operation -5...+55 °C (0.8...1.1Uc) Permissible -40...+70 °C for operation at Uc
Maximum operating altitude	3000 m without derating
Operating positions	± 30° possible, in relation to normal mounting plane without derating
Mechanical robustness	Shock & Vibration resistance conforming to IEC 61373 :2010 Vibrations contactor open: 0.964 (m/s ²) ² /Hz V* axis b/w 5 Hz and 20 Hz, 0.912 (m/s ²) ² /Hz in T* axis b/w 5 Hz and 20 Hz, 0.461 (m/s ²) ² /Hz in L* axis b/w 5 Hz and 20Hz Random type, 5 hours test Vibrations contactor closed: 0.0301 (m/s ²) ² /Hz in V* axis b/w 5 Hz and 20 Hz, 0.0060 (m/s ²) ² /Hz in T* axis b/w 5 Hz and 20 Hz, 0.0144 (m/s ²) ² /Hz in L* axis b/w 5 Hz and 20 Hz Random type, ten minute test Shocks contactor open: 30m/s ² in V* & T* axis, 50 m/s ² in L* axis Half sine type, 30 ms pulse
Material	EN 45545 HL2 compliant Class R22 for Railway Application EN 45545 HL3 compliant Class R22 for Railway Application
Height	181 mm
Width	120mm
Depth	127mm

Dimensional Drawing

V* -- Vertical, T* -- Transverse, L* -- Longitudinal

- ❖ Coil inter- changeability with-in same frame will not affect any design change in contactor
- ❖ All type contactor (s) are suitable to work in temperature range -5°C to 70°C & relative humidity up to 98 %

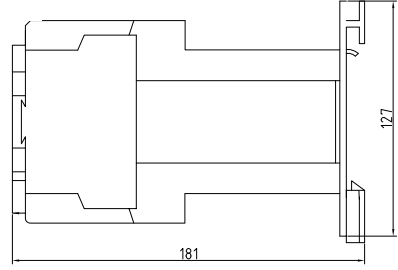

TC1D9511-R

With factory fitted TA1DN10 + TA9RC980U

Contactator 3P

Main

Product or component type	Contactator
Device short name	TC1D
Contactator application	Motor Control Resistive load
Utilisation category	AC-3 AC-1
Poles description	3P
Power pole contact composition	3 NO
Auxiliary contact composition	2 NO + 1 NC
[Ue] rated operational voltage	≤690 V AC 50/60Hz for power circuit
[Ie] rated operational current	90 A ($\theta \leq 55 \text{ }^\circ\text{C}$) AC-3 for power circuit $\leq 440\text{V}$ 125 A ($\theta \leq 45 \text{ }^\circ\text{C}$) AC-1 for power circuit $\leq 440\text{V}$
Motor power kW	45 kW at 415 V 45 kW at 440 V 45 kW at 500 V 25 kW at 220...230 V AC 50/60 Hz 45 kW at 380...400 V 55 kW at 660...690 V
[Uimp] rated impulse withstand voltage	8 kV (coil not connected to the power circuit) IEC 60947-4-1
Overvoltage category	III
Frequency Limits	25...400Hz
Irms rated making capacity	1200 A at 440 V for power circuit conforming to IEC 60947-4-1
Rated breaking capacity	1100 A at 440 V for power circuit conforming to IEC 60947-4-1 1100 A at 500 V for power circuit conforming to IEC 60947-4-1 640 A at 660-690 V for power circuit conforming to IEC 60947-4-1
Permissible short-time rating from cold state, no current flowing for preceding 15 minutes at $\theta \leq 40 \text{ }^\circ\text{C}$	135 A - 600 s for power circuit 320 A - 60 s for power circuit 640 A - 10 s for power circuit
Associated fuse rating	125 A gG at $\leq 440\text{V}$
Average impedance	0.8 mOhm at 50 Hz Ith 125 A for power circuit
[Ui] rated insulation voltage	1000 V conforming to IEC 60947-4-1
Electrical durability in million of operating cycles	1.3 AC-3 50 A at $U_e \leq 440\text{V}$ 1.6 AC-1 125 A at $U_e \leq 440\text{V}$
Power dissipation per pole	12.5 W AC-1 7.2 W AC-3
Tightening torque	9 N.m for power circuit
Mounting support	DIN rail Plate
Standards	IEC 60947-1 IEC 60947-4-1 BS EN 60947-4-1
Approvals	UL, CSA, CCC

Connections - terminals	Power circuit : screw clamp terminals - 2 flexible cable(s) 4...16 mm ² with cable end Power circuit : screw clamp terminals - 1 flexible cable(s) 4...50 mm ² with cable end Power circuit : screw clamp terminals - 2 solid cable(s) 4...25 mm ² without cable end Power circuit : screw clamp terminals - 1 solid cable(s) 4...50 mm ² without cable end Power circuit : screw clamp terminals - 2 flexible cable (s) 4...25 mm ² without cable end Power circuit : screw clamp terminals - 1 flexible cable (s) 4...50 mm ² without cable end Control circuit : screw clamp terminals - 2 solid cable(s) 1...4 mm ² without cable end Control circuit : screw clamp terminals - 1 solid cable(s) 1...4 mm ² without cable end Control circuit : screw clamp terminals - 2 flexible cable(s) 1...2.5 mm ² with cable end Control circuit : screw clamp terminals - 1 flexible cable(s) 1...4 mm ² with cable end Control circuit : screw clamp terminals - 2 flexible cable(s) 1...4 mm ² without cable end Control circuit : screw clamp terminals - 1 flexible cable(s) 1...4 mm ² without cable end
Tightening torque	1.2 N.m for control circuit
Mechanical durability in million of operating cycles	10 for 50 or 60 Hz coil 4 for 50/60 Hz coil at 50 Hz
Maximum Operating rate	3600 cycles per hour at $\theta \leq 55$ °C
[Uc] Control circuit voltage band	230V \pm 15% AC, 50/60 Hz
Average consumption at 20 °C at Uc 50Hz	Inrush(Cos ϕ 0.75) 50Hz Coil - 200 VA 50/60Hz Coil - 245 VA Sealed (Cos ϕ 0.3) 50Hz Coil - 20 VA 50/60Hz Coil - 26 VA
at Uc 60Hz	Inrush(Cos ϕ 0.75) 60Hz Coil - 220 VA 50/60Hz Coil - 245 VA Sealed (Cos ϕ 0.3) 60Hz Coil - 22 VA 50/60Hz Coil - 26 VA
Heat dissipation at 50/60Hz	6...10 W for control circuit
IP degree of protection	IP2X conforming to IEC 60529
Ambient air temperature around the device	Storage -60...+80 °C Operation -5...+70 °C (0.85...1.1Uc)
Maximum operating altitude	3000 m without derating
Operating positions	\pm 30° possible, in relation to normal mounting plane without derating
Mechanical Robustness	Shock & Vibration resistance conforming to IEC 61373 :2010 Vibrations contactor open: 0.964 (m/s ²) ² /Hz V* axis b/w 5 Hz and 20 Hz, 0.912 (m/s ²) ² /Hz in T* axis b/w 5 Hz and 20 Hz, 0.461 (m/s ²) ² /Hz in L* axis b/w 5 Hz and 20Hz Random type, 5 hours test Vibrations contactor closed: 0.0301 (m/s ²) ² /Hz in V* axis b/w 5 Hz and 20 Hz, 0.0060 (m/s ²) ² /Hz in T* axis b/w 5 Hz and 20 Hz, 0.0144 (m/s ²) ² /Hz in L* axis b/w 5 Hz and 20 Hz Random type, ten minute test Shocks contactor open: 30m/s ² in V* & T* axis, 50 m/s ² in L* axis Half sine type, 30 ms pulse
Material	EN 45545 HL2 compliant Class R22 for Railway Application EN 45545 HL3 compliant Class R22 for Railway Application
Height	127 mm
Width	85 mm
Depth	120 mm

Mounting Dimensions

V* -- Vertical, T* -- Transverse, L* -- Longitudinal

- ❖ Coil inter- changeability with-in same frame will not affect any design change in contactor
- ❖ All type contactor (s) are suitable to work in temperature range -5°C to 70°C & relative humidity up to 98 %

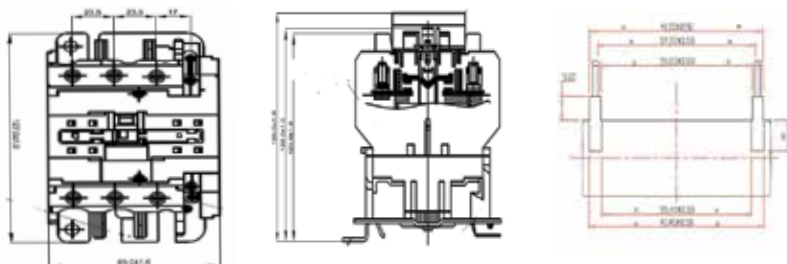

TCA3DN22-R

Parameter	TCA3DN22-R
Utilisation category (define all)	AC-15/ DC-13
Pole contact composition	Silver Alloy
Rated operational voltage	Please refer table
Rated impulse withstand voltage	4 kV
Ith	10 A
Irms rated making capacity	Not applicable for control relay
Rated short time withstand current	1 KA with SCPD
Associated fuse rating	10A gG/gL
Rated insulation voltage (IEC ? UL ? CSA ?)	1000 V AC
Screw clamp terminal	screw clamp terminals - 2 flexible cable(s) 1 .. 2.5 mm ² with cable end
	screw clamp terminals - 1 flexible cable(s) 1...4 mm ² with cable end
	screw clamp terminals - 2 solid cable(s) 1...4 mm ² without cable end
	screw clamp terminals - 1 solid cable(s) 1...4 mm ² without cable end
	screw clamp terminals - 2 flexible cable(s) 1...4 mm ² without cable end
	screw clamp terminals - 1 flexible cable(s) 1...4 mm ² without cable end
Tightening torque	1.2 Nm
Control ckt voltage limits	0.85... 1.1 Ucat 55 °C Operational
	0.1.. 0.75 Uc at 55 °C Drop-out
Operating time	35-43 ms Between Coil Energisation and opening of the NC contacts
	40-48 ms Closing of the NO contacts
	6-14 ms Between Coil De-energisation and opening of the NO contacts
	11-19 ms Closing of the NC contacts
Mechanical durability	20 Million cycles
Max operating rate	3600 cycles per hour
VA burden	9 ± 2 W
Sealed VA burden	9 ± 2 W
Min switching voltage	17V (Test report not available)
Min switching current	5 mA (Test report not available)
Non overlap time - energised / de energised	All available data added in operating time
Insulation resistance	>10 MOhm
L*B*H	74 x 115 x 45 mm
Standards : conformity to all	IEC 60947-5-1
Certifications : define all	CB
IP degree	IP 20, against direct finger contact conforming to IEC 60529
Protective treatment	NA
Operating altitude	±30° possible, in relation to normal vertical mounting plane without derating
Mechanical Robustness	Shock & Vibration resistance conforming to IEC 61373 :2010
	Vibrations contactor open:
	0.964 (m/s ²) ² /Hz V* axis b/w 5 Hz and 20 Hz,
	0.912 (m/s ²) ² /Hz in T* axis b/w 5 Hz and 20 Hz,
	0.461 (m/s ²) ² /Hz in L* axis b/w 5 Hz and 20Hz
	Random type, 5 hours test
	Vibrations contactor closed:
	0.0301 (m/s ²) ² /Hz in V* axis b/w 5 Hz and 20 Hz,
	0.0060 (m/s ²) ² /Hz in T* axis b/w 5 Hz and 20 Hz,
	0.0144 (m/s ²) ² /Hz in L* axis b/w 5 Hz and 20 Hz
	Random type, ten minute test
	Shocks contactor open:
	30m/s ² in V* & T* axis, 50 m/s ² in L* axis Half sine type, 30 ms pulse
	Material

Utilization Category : AC-15					
Rated Operational Voltage (Vac)	110/127	220/230	380/400	440	600
Rated Operational Current, Max (Aac)	3.64	2.19	1.32	1.14	0.84
Rated Operational Power (VA)	400	480	500	500	500
Utilization Category : DC-13					
Rated Operational Voltage (Vdc)	48	110	220	440	600
Rated Operational Current, Max (Adc)	1.88	0.69	0.31	0.14	0.1
Rated Operational Power (VA)	90	75	68	61	60

V* -- Vertical, T* -- Transverse, L* -- Longitudinal

- ❖ Coil inter- changeability with-in same frame will not affect any design change in contactor
- ❖ All type contactor (s) are suitable to work in temperature range -5°C to 70°C & relative humidity up to 98 %

Dimensions

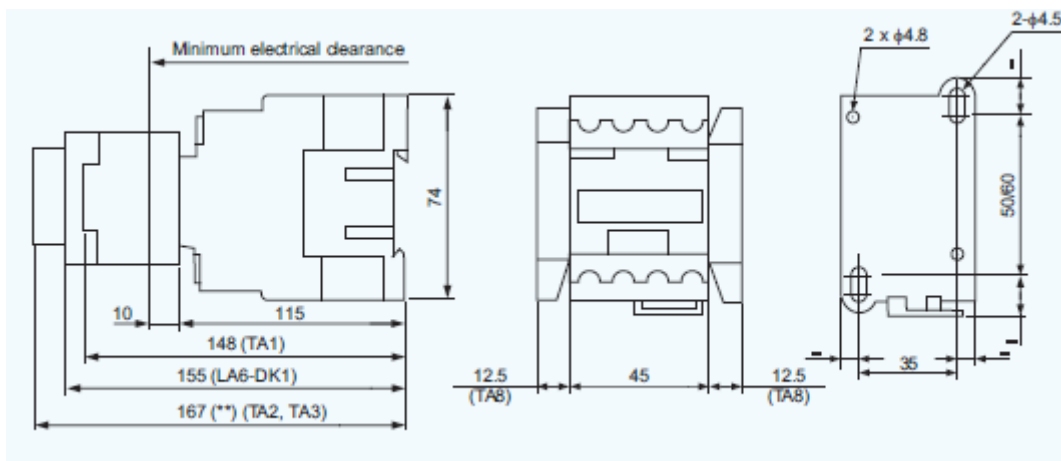

Technical Data Sheet

TCA3DN31-R

Parameter	TCA3DN31-R	
Utilisation category (define all)	AC-15/ DC-13	
Pole contact composition	Silver Alloy	
Rated operational voltage	Please refer table	
Rated impulse withstand voltage	4 kV	
I _{th}	10 A	
I _{rms} rated making capacity	Not applicable for control relay	
Rated short time withstand current	1 KA with SCPD	
Associated fuse rating	10A gG/gL	
Rated insulation voltage (IEC ? UL ? CSA ?)	1000 V AC	
Screw clamp terminal	screw clamp terminals - 2 flexible cable(s) 1 .. 2.5 mm ² with cable end	
	screw clamp terminals - 1 flexible cable(s) 1...4 mm ² with cable end	
	screw clamp terminals - 2 solid cable(s) 1...4 mm ² without cable end	
	screw clamp terminals - 1 solid cable(s) 1...4 mm ² without cable end	
	screw clamp terminals - 2 flexible cable(s) 1...4 mm ² without cable end	
	screw clamp terminals - 1 flexible cable(s) 1...4 mm ² without cable end	
Tightening torque	1.2 Nm	
Control ckt voltage limits	0.85.... 1.1 U _{cat} 55 °C Operational	
	0.1.. 0.75 U _c at 55 °C Drop-out	
Operating time	35-43 ms Between Coil Energisation and opening of the NC contacts	
	40-48 ms Closing of the NO contacts	
	6-14 ms Between Coil De-energisation and opening of the NO contacts	
	11-19 ms Closing of the NC contacts	
Mechanical durability	20 Million cycles	
Max operating rate	3600 cycles per hour	
VA burden	9 ± 2 W	
Sealed VA burden	9 ± 2 W	
Min switching voltage	17V (Test report not available)	
Min switching current	5 mA (Test report not available)	
Non overlap time - energised / de energised	All available data added in operating time	
Insulation resistance	>10 MOhm	
L*B*H	74 x 115 x 45 mm	
Standards : conformity to all	IEC 60947-5-1	
Certifications : define all	CB	
IP degree	IP 20, against direct finger contact conforming to IEC 60529	
Protective treatment	NA	
Operating altitude	±30° possible, in relation to normal vertical mounting plane without derating	
Mechanical Robustness	Shock & Vibration resistance conforming to IEC 61373 :2010	
	Vibrations contactor open:	
	0.964 (m/s ²) ² /Hz V* axis b/w 5 Hz and 20 Hz,	
	0.912 (m/s ²) ² /Hz in T* axis b/w 5 Hz and 20 Hz,	
	0.461 (m/s ²) ² /Hz in L* axis b/w 5 Hz and 20Hz	
	Random type, 5 hours test	
	Vibrations contactor closed:	
	0.0301 (m/s ²) ² /Hz in V* axis b/w 5 Hz and 20 Hz,	
	0.0060 (m/s ²) ² /Hz in T* axis b/w 5 Hz and 20 Hz,	
	0.0144 (m/s ²) ² /Hz in L* axis b/w 5 Hz and 20 Hz	
	Random type, ten minute test	
	Shocks contactor open:	
	30m/s ² in V* & T* axis, 50 m/s ² in L* axis Half sine type, 30 ms pulse	
	Material	EN 45545 HL2 compliant Class R22 for Railway Application EN 45545 HL3 compliant Class R22 for Railway Application

Utilization Category : AC-15					
Rated Operational Voltage (Vac)	110/127	220/230	380/400	440	600
Rated Operational Current, Max (Aac)	3.64	2.19	1.32	1.14	0.84
Rated Operational Power (VA)	400	480	500	500	500
Utilization Category : DC-13					
Rated Operational Voltage (Vdc)	48	110	220	440	600
Rated Operational Current, Max (Adc)	1.88	0.69	0.31	0.14	0.1
Rated Operational Power (VA)	90	75	68	61	60

V* -- Vertical, T* -- Transverse, L* -- Longitudinal

- ❖ Coil inter- changeability with-in same frame will not affect any design change in contactor
- ❖ All type contactor (s) are suitable to work in temperature range -5°C to 70°C & relative humidity up to 98 %

Dimensions

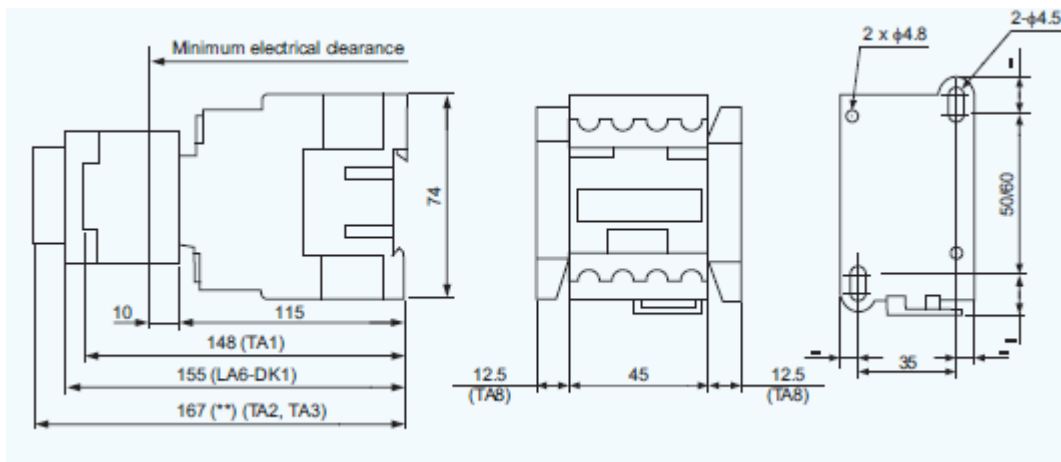

LA9F980N(BR)-R

Coil suppressor – RC circuit
265-415V AC

Main

Product or component type	Coil suppressor module
Device short name	LA9F980N(BR)-R
Mounting mode	Using Lugs
Mounting location	Side
Suppressor technology	RC circuit
[Ue] coil voltage	265-415V AC
Ambient air temperature around the device	Storage -25...+70 °C Operation -5...+55 °C
Product weight	21 g
Mechanical Robustness	Shock & Vibration resistance conforming to IEC 61373 : 2010 Vibrations contactor open: 0.964 (m/s ²) ² /Hz V* axis b/w 5 Hz and 20 Hz, 0.912 (m/s ²) ² /Hz in T* axis b/w 5 Hz and 20 Hz, 0.461 (m/s ²) ² /Hz in L* axis b/w 5 Hz and 20Hz Random type, 5 hours test Vibrations contactor closed: 0.0301 (m/s ²) ² /Hz in V* axis b/w 5 Hz and 20 Hz, 0.0060 (m/s ²) ² /Hz in T* axis b/w 5 Hz and 20 Hz, 0.0144 (m/s ²) ² /Hz in L* axis b/w 5 Hz and 20 Hz Random type, ten minute test Shocks contactor open: 30m/s ² in V* & T* axis, 50 m/s ² in L* axis Half sine type, 30 ms pulse
Material	EN 45545 HL2 compliant Class R22 for Railway Application EN 45545 HL3 compliant Class R22 for Railway Application

V* -- Vertical, T* -- Transverse, L* -- Longitudinal

- ❖ Coil inter- changeability with-in same frame will not affect any design change in contactor
- ❖ All type contactor (s) are suitable to work in temperature range -5°C to 70°C & relative humidity up to 98 %

Dimensional drawing

(in mm)

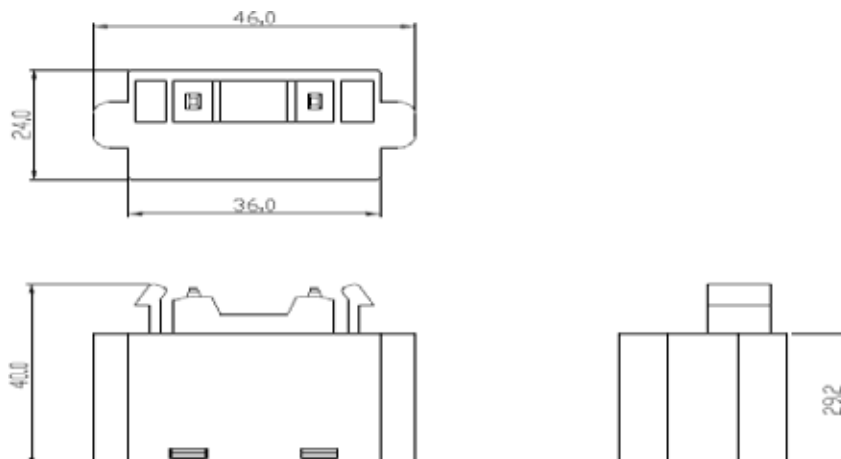

LC1FDP1154A-R

F-Range contactor - 4P (4 NO)

200 A - AC-1
115 A - AC-3

Main

Range	Robusta-R
Product name	F-Range
Product or component type	Contactor
Device short name	LC1FDP
Contactor application	Resistive load Motor Control
Utilisation category	AC-1 AC-3 AC-6a
Poles description	4P
Power pole contact composition	4 NO
[Ue] rated operational voltage	<= 1000 V AC 50/60 Hz
[Ie] rated operational current	200A (at $\theta \leq 40^{\circ}\text{C}$) at <= 440 V AC-1 115A (at $\theta \leq 55^{\circ}\text{C}$) at <= 440 V AC-3
Motor power KW	55kW at 380...400 V AC 50/60Hz (AC-3) 59kW at 415 V AC 50/60 Hz (AC-3) 59kW at 440 V AC 50/60 Hz (AC-3) 75kW at 500 V AC 50/60 Hz (AC-3) 30kW at 220...240 V AC 50/60 Hz (AC-3) 80kW at 660...690 V AC 50/60Hz (AC-3) 18.5kW at 400 V AC 50/60 Hz (AC-4)
[Uc] control circuit voltage	48...500 V AC 40...400 Hz with LX9FF coil 24...440 V DC with LX4FF coil 24...550 V AC 50/60 Hz with LX1FF coil
[Uimp] rated impulse withstand voltage	8kV
[Ui] rated insulation voltage	1000 V conforming to IEC 60947-4-1
Overvoltage category	III
[Ith] conventional free air thermal current	200A (at $\theta \leq 40^{\circ}\text{C}$)
Irms rated making capacity	1300A at 220...415V conforming to IEC 60947-4-1
Rated breaking capacity	1300A at 220...415V conforming to IEC-60947-4-1 1100A at 500V conforming to IEC-60947-4-1 900A at 660...690V conforming to IEC-60947-4-1 400A at 1000V conforming to IEC-60947-4-1
[Icw] rated short-time withstand current from cold state, no current flowing for preceding 60 minutes (Theoretical)	1100A at $\theta \leq 40^{\circ}\text{C}$ - 10 s 640A at $\theta \leq 40^{\circ}\text{C}$ - 30 s 520A at $\theta \leq 40^{\circ}\text{C}$ - 1 min 400A at $\theta \leq 40^{\circ}\text{C}$ - 3 min 320A at $\theta \leq 40^{\circ}\text{C}$ - 10 min
Ambient air temperature for operation	-5...55°C
Ambient air temperature for storage	-25 to 70°C

Technical Data Sheet

Mechanical Robustness	Shock & Vibration resistance conforming to IEC 61373 :2010 Vibrations contactor open: 0.964 (m/s ²) ² /Hz V* axis b/w 5 Hz and 20 Hz, 0.912 (m/s ²) ² /Hz in T* axis b/w 5 Hz and 20 Hz, 0.461 (m/s ²) ² /Hz in L* axis b/w 5 Hz and 20Hz Random type, 5 hours test Vibrations contactor closed: 0.0301 (m/s ²) ² /Hz in V* axis b/w 5 Hz and 20 Hz, 0.0060 (m/s ²) ² /Hz in T* axis b/w 5 Hz and 20 Hz, 0.0144 (m/s ²) ² /Hz in L* axis b/w 5 Hz and 20 Hz Random type, ten minute test Shocks contactor open: 30m/s ² in V* & T* axis, 50 m/s ² in L* axis Half sine type, 30 ms pulse
Material	EN 45545 HL2 compliant Class R22 for Railway Application EN 45545 HL3 compliant Class R22 for Railway Application
Associated fuse rating	200A gG at <= 440 V
Average impedance per pole	0.40mOhm - lth 200A 50 Hz
[Uij] rated insulation voltage	1000V conforming to IEC 60947-4-1
Power dissipation per pole	18W AC-1 6W AC-3
Control circuit voltage limits	Operational: 0.85. 1.1 Uc
Mounting support	Plate
Standards	EN 60947-4-1 IEC 60947-4-1 EN 60947-1 IEC 60947-1

Connections - terminals	Power circuit: lugs-ring terminals 1 cable(s) 95mm ² Power circuit: connector 1 cable(s) 95mm ² Power circuit: bar 2 cable(s) - busbar cross section: 20 x 3 mm Control circuit: screw clamp terminals 1 cable(s) 1...4mm ² flexible without cable end Control circuit: screw clamp terminals 2 cable(s) 1...2.5mm ² flexible with cable end Control circuit: screw clamp terminals 1 cable(s) 1...4mm ² flexible with cable end Control circuit: screw clamp terminals 2 cable(s) 1...4mm ² solid without cable end Control circuit: screw clamp terminals 1 cable(s) 1...4mm ² solid without cable end Control circuit: screw clamp terminals 2 cable(s) 1...4mm ² flexible without cable end
Tightening torque	Power circuit: 10 Nm Control circuit: 1.2 Nm
Maximum operating rate	2400cyc/h at $\theta \leq 55^{\circ}\text{C}$
Mechanical Durability (in millions of operating cycles)	5
Maximum operating altitude	3000 m without derating
Operating positions	$\pm 30^{\circ}$ possible, in relation to normal vertical mounting plane
IP degree of protection	IP 20 front face with shrouds# conforming to IEC 60529
Height	162mm
Width	200.5mm
Depth	175mm

#To be ordered separately

V* -- Vertical, T* -- Transverse, L* -- Longitudinal

- ❖ Coil inter- changeability with-in same frame will not affect any design change in contactor
- ❖ All type contactor (s) are suitable to work in temperature range -5°C to 70°C & relative humidity up to 98 %

Switching of 3 Phase LV/LV Transformer AC6a

Contactor Size		LC1FDP1154_R
Maximum Permissible Closing Current peak	Amp	1700
Maximum operating power in kVA	220V	25
	380V	50
	415V/440V	55
	500V	65
	660V	80
	1000V	100

Dimensions

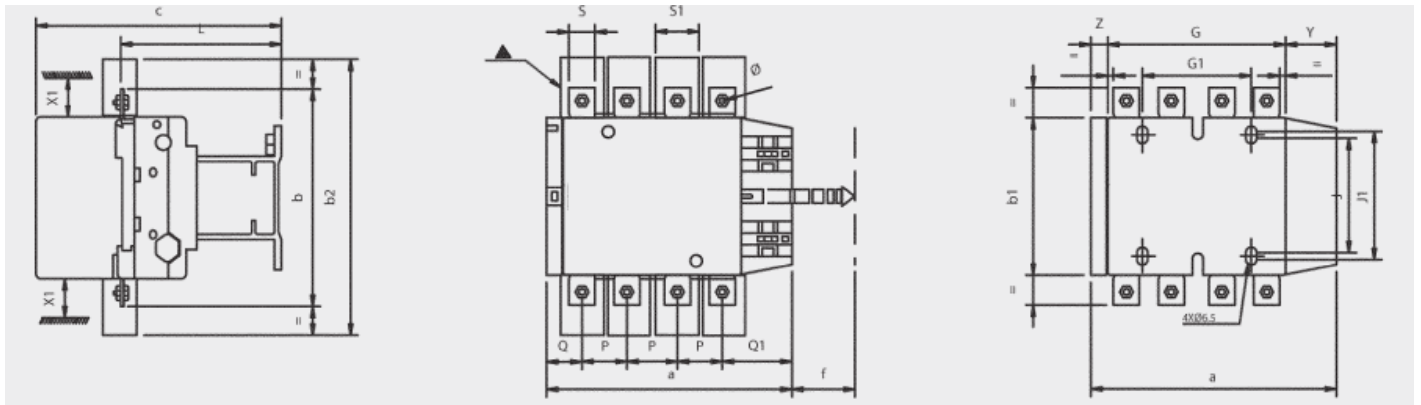

LC1-	a	b	b1	b2	c	f	G	G1	J	J1	L	M	P	Q	Q1	S	S1	Y	Z	Ø
FDP115A	163.5	162	137	265	172	131	106	80	106	120	107	147	37	29.5	60	15	27	44	13.5	M6
FDP1154A	200.5	162	137	265	172	131	143	80	106	120	107	147	37	29.5	60	15	27	44	13.5	M6
FDP150A	163.5	171	137	301	172	131	106	80	106	120	107	150	40	26.5	57.5	20	34	44	13.5	M8
FDP1504A	200.5	171	137	301	172	131	143	80	106	120	107	150	40	26.5	55.5	20	34	44	13.5	M8
FDP185A	168.5	174	137	305	181	130	111	80	106	120	113.5	154	40	29	59.5	20	34	44	13.5	M8
FDP1854A	208.5	174	137	305	181	130	151	80	106	120	113.5	154	40	29	59.5	20	34	44	13.5	M8
FDP225A	168.5	197	137	364	181	130	111	80	106	120	113.5	172	48	20	51.5	25	44.5	44	13.5	M10
FDP2254A	208.5	197	137	364	181	130	151	80	106	120	113.5	172	48	17	47.5	25	44.5	44	13.5	M10
FDP265A	201.5	203	145	370	214	147	142	96	106	120	141	178	48	39	66.5	25	44.5	38	21.5	M10
FDP2654A	244.5	203	145	370	214	147	190	96	106	120	141	178	48	34	66.5	25	44.5	38	21.5	M10
FDP330A	206	206	145	375	220	147	154.5	96	106	120	147	181	48	43	74	25	44.5	38	20.5	M10
FDP3304A	254	206	145	375	220	147	202.5	96	106	120	147	181	48	43	74	25	44.5	38	20.5	M10

Technical Data Sheet

LC1FDP1504A-R
 F-Range contactor - 4P (4 NO)
 250 A - AC-1
 150 A - AC-3

Main

Range	Robusta-R
Product name	F-Range
Product or component type	Contactor
Device short name	LC1FDP
Contactor application	Resistive load Motor Control
Utilization category	AC1 AC3 AC6a
Poles description	4P
Power pole contact composition	4 NO
[Ue] rated operational voltage	<= 1000 V AC 50/60 Hz
[Ie] rated operational current	250A (at $\theta \leq 40^{\circ}\text{C}$) at <= 440 V AC-1 150A (at $\theta \leq 55^{\circ}\text{C}$) at <= 440 V AC-3
Motor power kW	75kW at 380...400V AC 50/60 Hz (AC-3) 80 kW at 415 V AC 50/60 Hz (AC-3) 80 kW at 440 V AC 50/60 Hz (AC-3) 90 kW at 500 V AC 50/60 Hz (AC-3) 40kW at 220...240 V AC 50/60 Hz (AC-3) 100kW at 660...690V AC 50/60Hz (AC-3) 22 kW at 400 V AC 50/60 Hz (AC-4)
[Uc] control circuit voltage	48...500 V AC 40...400 Hz with LX9FF coil 24...440 V DC with LX4FF coil 24...550 V AC 50/60 Hz with LX1FF coil
[Uimp] rated impulse withstand voltage	8kV
[Ui] rated insulation voltage	1000 V conforming to IEC 60947-4-1
Overvoltage category	III
[Ith] conventional free air thermal current	250A (at $\theta \leq 40^{\circ}\text{C}$)
Irms rated making capacity	1700A at 220...415V conforming to IEC 60947-4-1
Rated breaking capacity	1500A at 220...415V conforming to IEC 60947-4-1 1200A at 500V conforming to IEC 60947-4-1 1100A at 660...690V conforming to IEC 60947-4-1 450A at 1000V conforming to IEC 60947-4-1
[Icw] rated short-time withstand current from cold state, no current flowing for preceding 60 minutes	1200A at $\theta \leq 40^{\circ}\text{C}$ - 10 s 700A at $\theta \leq 40^{\circ}\text{C}$ - 30 s 600A at $\theta \leq 40^{\circ}\text{C}$ - 1 min 450A at $\theta \leq 40^{\circ}\text{C}$ - 3 min 350A at $\theta \leq 40^{\circ}\text{C}$ - 10 min
Ambient air temperature for operation	-5...55°C
Ambient air temperature for storage	-25...70°C

Mechanical robustness	<p>Shock & Vibration resistance conforming to IEC 61373: 2010</p> <p>Vibrations contactor open:</p> <p>0.964 (m/s²)² /Hz V* axis b/w 5 Hz and 20 Hz, 0.912 (m/s²)² /Hz in T* axis b/w 5 Hz and 20 Hz, 0.461 (m/s²)² /Hz in L* axis b/w 5 Hz and 20Hz</p> <p>Random type, 5 hours test</p> <p>Vibrations contactor closed:</p> <p>0.0301 (m/s²)² /Hz in V* axis b/w 5 Hz and 20 Hz, 0.0060 (m/s²)² /Hz in T* axis b/w 5 Hz and 20 Hz, 0.0144 (m/s²)² /Hz in L* axis b/w 5 Hz and 20 Hz</p> <p>Random type, ten minute test</p> <p>Shocks contactor open:</p> <p>30m/s² in V* & T* axis, 50 m/s² in L* axis Half sine type, 30 ms pulse</p>
Material	<p>EN 45545 HL2 compliant Class R22 for Railway Application</p> <p>EN 45545 HL3 compliant Class R22 for Railway Application</p>
Associated fuse rating	250A gG at <= 440 V
Average impedance per pole	0.40mOhm - lth 250A 50 Hz
[Ui] rated insulation voltage	1000V conforming to IEC 60947-4-1
Power dissipation per pole	25W AC-1 9W AC-3
Control circuit voltage limits	Operational: 0.85. 1.1 Uc
Mounting support	Plate
Standards	<p>EN 60947-4-1</p> <p>IEC 60947-4-1</p> <p>EN 60947-1</p> <p>IEC 60947-1</p>
Connections - terminals	<p>Power circuit: lugs-ring terminals 1 cable(s) 120mm²</p> <p>Power circuit: connector 1 cable(s) 120mm²</p> <p>Power circuit: bar 2 cable(s) - busbar cross section: 25 x 3 mm</p> <p>Control circuit: screw clamp terminals 1 cable(s) 1...4mm² flexible without cable end</p> <p>Control circuit: screw clamp terminals 2 cable(s) 1...2.5mm² flexible with cable end</p> <p>Control circuit: screw clamp terminals 1 cable(s) 1...4mm² flexible with cable end</p> <p>Control circuit: screw clamp terminals 2 cable(s) 1...4mm² solid without cable end</p> <p>Control circuit: screw clamp terminals 1 cable(s) 1...4mm² solid without cable end</p> <p>Control circuit: screw clamp terminals 2 cable(s) 1...4mm² flexible without cable end</p>
Tightening torque	<p>Power circuit: 18N.m</p> <p>Control circuit: 1.2N.m</p>
Maximum operating rate	2400cyc/h at $\theta \leq 55^{\circ}\text{C}$
Mechanical Durability (in millions of operating cycles)	10
Maximum operating altitude	3000 m without derating
Operating positions IP degree of protection	<p>$\pm 30^{\circ}$ possible, in relation to normal vertical mounting plane</p> <p>IP 20 front face with shrouds# conforming to IEC 60529</p>
Height	170mm
Width	163.5mm
Depth	175mm

#To be ordered separately ,

T* -- Transverse, L* -- Longitudinal, V* -- Vertical

- ❖ Coil inter- changeability with-in same frame will not affect any design change in contactor
- ❖ All type contactor (s) are suitable to work in temperature range -5°C to 70°C & relative humidity up to 98 %

Technical Data Sheet

Switching of 3 Phase LV/LV Transformer AC6a		
Contractor Size	LC1FDP1504_R	
Maximum Operating Closing Current Peak (Amp)	2200	
Maximum Operating Power (KVA)	220V	25
	380V	50
	415V/440 V	55
	500V	65
	660V	80
	1000V	100

Dimensions (mm)

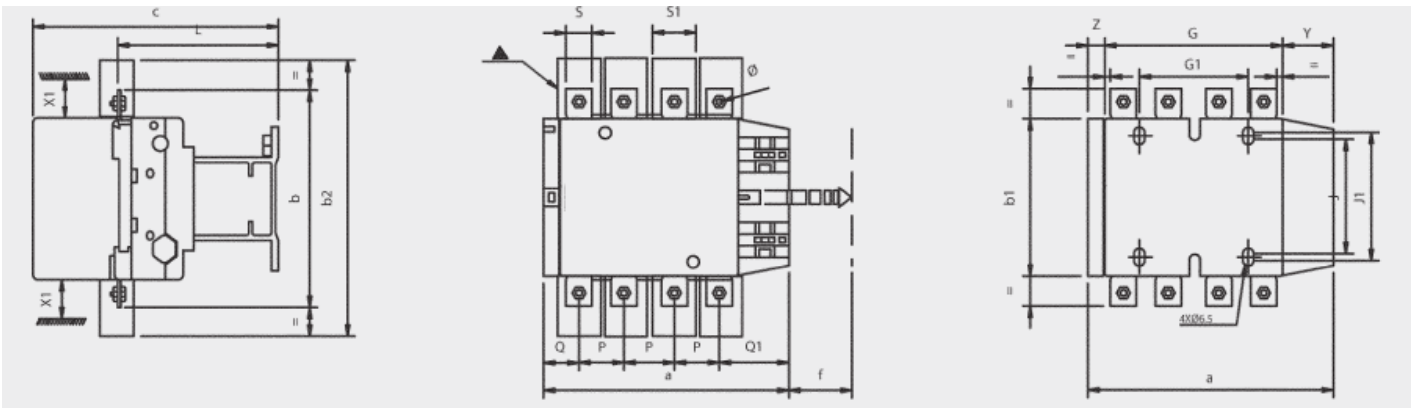

LC1-	a	b	b1	b2	c	f	G	G1	J	J1	L	M	P	Q	Q1	S	S1	Y	Z	φ
FDP115A	163.5	162	137	265	172	131	106	80	106	120	107	147	37	29.5	60	15	27	44	13.5	M6
FDP1154A	200.5	162	137	265	172	131	143	80	106	120	107	147	37	29.5	60	15	27	44	13.5	M6
FDP150A	163.5	171	137	301	172	131	106	80	106	120	107	150	40	26.5	57.5	20	34	44	13.5	M8
FDP1504A	200.5	171	137	301	172	131	143	80	106	120	107	150	40	25.5	55.5	20	34	44	13.5	M8
FDP185A	168.5	174	137	305	181	130	111	80	106	120	113.5	154	40	29	59.5	20	34	44	13.5	M8
FDP1854A	208.5	174	137	305	181	130	151	80	106	120	113.5	154	40	29	59.5	20	34	44	13.5	M8
FDP225A	168.5	197	137	364	181	130	111	80	106	120	113.5	172	48	20	51.5	25	44.5	44	13.5	M10
FDP2254A	208.5	197	137	364	181	130	151	80	106	120	113.5	172	48	17	47.5	25	44.5	44	13.5	M10
FDP265A	201.5	203	145	370	214	147	142	96	106	120	141	178	48	39	66.5	25	44.5	38	21.5	M10
FDP2654A	244.5	203	145	370	214	147	190	96	106	120	141	178	48	34	66.5	25	44.5	38	21.5	M10
FDP330A	206	206	145	375	220	147	154.5	96	106	120	147	181	48	43	74	25	44.5	38	20.5	M10
FDP3304A	254	206	145	375	220	147	202.5	96	106	120	147	181	48	43	74	25	44.5	38	20.5	M10

LC1FDP2254A-R

F-Range contactor - 4P (4 NO)

315 A - AC-1

225 A - AC-3

Main

Range	Robusta-R
Product name	F-Range
Product or component type	Contactor
Device short name	LC1FDP
Contactor application	Resistive load Motor Control
Utilisation category	AC-1 AC-3 AC-6a
Poles description	4P
Power pole contact composition	4 NO
[Ue] rated operational voltage	<= 1000 V AC 50/60 Hz
[Ie] rated operational current	315A (at $\theta \leq 40^\circ\text{C}$) at <= 440 V AC-1 225A (at $\theta \leq 55^\circ\text{C}$) at <= 440 V AC-3
Motor power kW	110kW at 380...400V AC 50/60 Hz (AC-3) 110 kW at 415 V AC 50/60 Hz (AC-3) 110 kW at 440 V AC 50/60 Hz (AC-3) 129 kW at 500 V AC 50/60 Hz (AC-3) 63kW at 220...240V AC 50/60Hz (AC-3) 129kW at 660...690V AC 50/60 Hz (AC-3) 40 kW at 400 V AC 50/60 Hz (AC-4)
[Uc] control circuit voltage	48...500V AC 40...400 Hz with LX9FG coil 24...440 V DC with LX4FG coil 24...550 V AC 50/60 Hz with LX1FG coil
[Uimp] rated impulse withstand voltage	8kV
[Ui] rated insulation voltage	1000 V conforming to IEC 60947-4-1
Overvoltage category	III
[Ith] conventional free air thermal Current	315A (at $\theta \leq 40^\circ\text{C}$)
Irms rated making capacity Rated breaking capacity	2460A 220...415V conforming to IEC 60947-4-1 2050A at 220...415V conforming to IEC 60947-4-1 1850A at 500V conforming to IEC 60947-4-1 1350A at 660...690V conforming to IEC 60947-4-1 780A at 1000V conforming to IEC 60947-4-1
[Icw] rated short-time withstand current from cold state, no current flowing for preceding 60 minutes	1800A at $\theta \leq 40^\circ\text{C}$ - 10 s 1000A at $\theta \leq 40^\circ\text{C}$ - 30 s 850A at $\theta \leq 40^\circ\text{C}$ - 1 min 560A at $\theta \leq 40^\circ\text{C}$ - 3 min 440A at $\theta \leq 40^\circ\text{C}$ - 10 min
Ambient air temperature for operation	-5...55°C
Ambient air temperature for storage	-25...70°C

Technical Data Sheet

Mechanical Robustness	Shock & Vibration resistance conforming to IEC 61373: 2010 Vibrations contactor open: 0.964 (m/s ²) ² /Hz V* axis b/w 5 Hz and 20 Hz, 0.912 (m/s ²) ² /Hz in T* axis b/w 5 Hz and 20 Hz, 0.461 (m/s ²) ² /Hz in L* axis b/w 5 Hz and 20Hz Random type, 5 hours test Vibrations contactor closed: 0.0301 (m/s ²) ² /Hz in V* axis b/w 5 Hz and 20 Hz, 0.0060 (m/s ²) ² /Hz in T* axis b/w 5 Hz and 20 Hz, 0.0144 (m/s ²) ² /Hz in L* axis b/w 5 Hz and 20 Hz Random type, ten minute test Shocks contactor open: 30m/s ² in V* & T* axis, 50 m/s ² in L* axis Half sine type, 30 ms pulse
Material	EN 45545 HL2 compliant Class R22 for Railway Application EN 45545 HL3 compliant Class R22 for Railway Application
Associated fuse rating	315A gG at <= 440 V
Average impedance per pole	0.36mOhm - lth 315A 50 Hz
[Ui] rated insulation voltage	1000V conforming to IEC 60947-4-1
Power dissipation per pole	35W AC-1 18W AC-3
Control circuit voltage limits	Operational: 0.85. 1.1 Uc
Mounting support	Plate
Standards	EN 60947-4-1 IEC 60947-4-1 EN 60947-1 IEC 60947-1
Connections - terminals	Power circuit: lugs-ring terminals 1 cable(s) 185mm ² Power circuit: connector 1 cable(s) 185mm ² Power circuit: bar 2 cable(s) - busbar cross section: 32 x 4 mm Control circuit: screw clamp terminals 1 cable(s) 1...4mm ² flexible without cable end Control circuit: screw clamp terminals 2 cable(s) 1...2.5mm ² flexible with cable end Control circuit: screw clamp terminals 1 cable(s) 1...4mm ² flexible with cable end Control circuit: screw clamp terminals 2 cable(s) 1...4mm ² solid without cable end Control circuit: screw clamp terminals 1 cable(s) 1...4mm ² solid without cable end Control circuit: screw clamp terminals 2 cable(s) 1...4mm ² flexible without cable end
Tightening torque	Power circuit: 35N.m Control circuit: 1.2N.m
Maximum operating rate	2400cyc/h at $\theta \leq 55^{\circ}\text{C}$
Mechanical Durability (in millions of operating cycles)	10
Maximum operating altitude	3000 m without derating
Operating positions	$\pm 30^{\circ}$ possible, in relation to normal vertical mounting plane
IP degree of protection	IP 20 front face with shrouds# conforming to IEC 60529
Height	197mm
Width	208.5mm
Depth	186mm

#To be ordered separately

V* -- Vertical, T* -- Transverse, L* -- Longitudinal

- ❖ Coil inter- changeability with-in same frame will not affect any design change in contactor
- ❖ All type contactor (s) are suitable to work in temperature range -5°C to 70°C & relative humidity up to 98

Switching of 3 Phase LV/LV Transformer AC6a

Contactor Size		LC1FDP2254_R
Maximum Permissible Closing Current peak	Amp	3000
Maximum operating power in kVA	220V	45
	380V	80
	415V/440V	90
	500V	100
	660V	130
	1000V	170

Dimensions

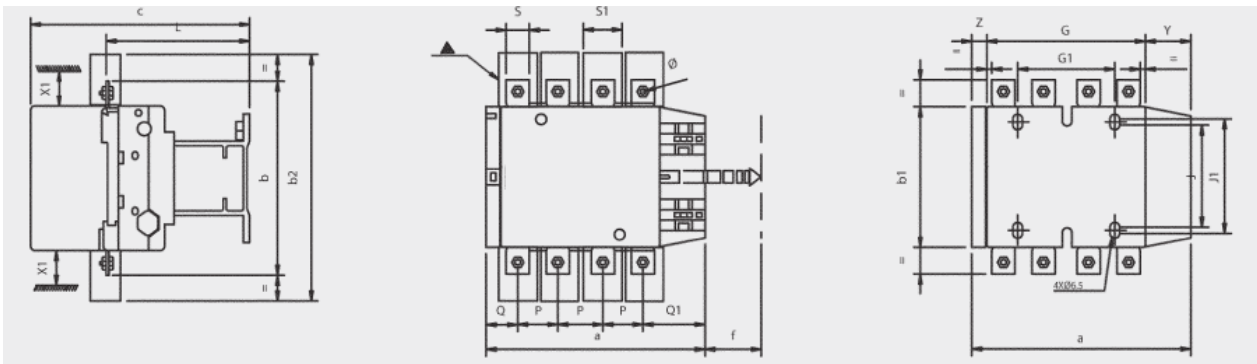

LC1-	a	b	b1	b2	c	f	G	G1	J	J1	L	M	P	Q	Q1	S	S1	Y	Z	φ
FDP115A	163.5	162	137	265	172	131	106	80	106	120	107	147	37	29.5	60	15	27	44	13.5	M6
FDP1154A	200.5	162	137	265	172	131	143	80	106	120	107	147	37	29.5	60	15	27	44	13.5	M6
FDP150A	163.5	171	137	301	172	131	106	80	106	120	107	150	40	26.5	57.5	20	34	44	13.5	M8
FDP1504A	200.5	171	137	301	172	131	143	80	106	120	107	150	40	25.5	55.5	20	34	44	13.5	M8
FDP185A	168.5	174	137	305	181	130	111	80	106	120	113.5	154	40	29	59.5	20	34	44	13.5	M8
FDP1854A	208.5	174	137	305	181	130	151	80	106	120	113.5	154	40	29	59.5	20	34	44	13.5	M8
FDP225A	168.5	197	137	364	181	130	111	80	106	120	113.5	172	48	20	51.5	25	44.5	44	13.5	M10
FDP2254A	208.5	197	137	364	181	130	151	80	106	120	113.5	172	48	17	47.5	25	44.5	44	13.5	M10
FDP265A	201.5	203	145	370	214	147	142	96	106	120	141	178	48	39	66.5	25	44.5	38	21.5	M10
FDP2654A	244.5	203	145	370	214	147	190	96	106	120	141	178	48	34	66.5	25	44.5	38	21.5	M10
FDP330A	206	206	145	375	220	147	154.5	96	106	120	147	181	48	43	74	25	44.5	38	20.5	M10
FDP3304A	254	206	145	375	220	147	202.5	96	106	120	147	181	48	43	74	25	44.5	38	20.5	M10



Mini Contactor

- Conforms IEC 60947-4-1; IS/IEC 60947-4-1
- Power contactor range: 9A~16A; 3P with 1 built in auxiliary contact
- Control relays in 5 variants in AC & DC coil
- Common add-on accessories-front/side auxiliary contact block, electronics timer, mechanical interlock & coil suppressor
- Compatible overload relays range: 0.1A~16A; auto/manual reset with built-in single phase protection

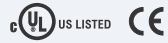

D Range Contactor

- Conforms IEC 60947-4-1; IS/IEC 60947-4-1
- Power contactor range: 9A~16A; 3P with 1 built in auxiliary contact
- Control relays in 5 variants in AC & DC coil
- Common add-on accessories-front/side auxiliary contact block, electronics timer, mechanical interlock & coil suppressor
- Compatible overload relays range: 0.1A~16A; auto/manual reset with built-in single phase protection



Capacitor Duty Contactor

- Conforms IEC 60947-4-1; IS/IEC 60947-4-1
- Range: 7kVAR ~ 100kVAR
- 3 Pole, 415V AC
- AC -6b utilization category
- Excellent damping of In-rush current
- Switching of capacitor banks without derating
- Wide range AC coil options 50/60Hz



Definite Purpose Contactor

- Range: 20A, 25A, 30A & 40A in 1P, 2P & 3P variants
- Electrical life: 200,000 operations
- Ambient air temperature : -40° to +65 °C
- Ambient air dampness around the device: 45% to 85% RH
- Coil voltage: 80% to 110% of rate voltage
- Application: Ventilation & HVAC: Heating elements, power supplies & compressors



2 Pole Contactor

- Range: 20A, 25A & 40A AC3
- Extra wide band Coil
- Add on block



4 Pole Contactor

- Heavy duty contactor range: 20, 25 & 40A AC3
- Extra wide band coil
- Mechanical interlock & add-on block



Marketing offices spread all over India

REGISTERED OFFICE

210, 211 & 212, Second Floor, 'Salcon Aurum' Building
Plot No. 4, Jasola District Centre, New Delhi - 110 025 (INDIA)
Tel.: +91 11 6922 5600 | Email : info@cselectric.co.in

CENTRAL MARKETING OFFICE

C-60, Wing-A, Phase-II, Noida, District Gautam Budh Nagar, Uttar Pradesh - 201 305 (INDIA)
Tel.: +91 120 387 4800 / 01 | Email: cmo@cselectric.co.in

CUSTOMER CARE

Toll Free Number: 1800 572 2012 | Email : customercare@cselectric.co.in

NORTHERN REGION

DELHI
Email: cmo@cselectric.co.in

LUDHIANA
Email: ludhiana@cselectric.co.in

LUCKNOW
Email: lucknow@cselectric.co.in

KANPUR
Email: lucknow@cselectric.co.in

JAIPUR
Email: jaipur@cselectric.co.in

CENTRAL REGION

INDORE
Email: indore@cselectric.co.in

RAIPUR
Email: raipur@cselectric.co.in

NAGPUR
Email: nagpur@cselectric.co.in

EASTERN REGION

KOLKATA
Email: kolkata@cselectric.co.in

GUWAHATI
Email: guwahati@cselectric.co.in

RANCHI
Email: ranchi@cselectric.co.in

BHUBANESWAR
Email: bhubaneshwar@cselectric.co.in

WESTERN REGION
MUMBAI
Email: mumbai@cselectric.co.in

PUNE
Email: pune@cselectric.co.in

AHMEDABAD
Email: ahmedabad@cselectric.co.in

RAJKOT
Email: ahmedabad@cselectric.co.in

BARODA
Email: baroda@cselectric.co.in

SURAT
Email: surat@cselectric.co.in

SOUTHERN REGION
CHENNAI
Email: chennai@cselectric.co.in

COIMBATORE
Email: coimbatore@cselectric.co.in

KOCHI
Email: cochin@cselectric.co.in

MADURAI
Email: commercial,madurai@cselectric.co.in

BENGALURU
Email: bangalore@cselectric.co.in

HYDERABAD
Email: hyderabad@cselectric.co.in

VIJAYAWADA
Email: vijayawada@cselectric.co.in

RESIDENT ENGINEERS

AHMEDABAD: Visnagar **BANGALORE:** Bellary, Hassan, Hubli, Mangalore **BARODA:** Anand, Vapi **BHUBANESWAR:** Behrampur, Cuttack, Rourkela, Sambalpur **CHENNAI:** Vellore, Trichy **KOCHI:** Kollam **COIMBATORE:** Erode **DELHI & HARYANA:** Gurugram, Hissar, Panipat, **UP (W) & UK:** Agra, Bareilly, Dehradun, Ghaziabad, Meerut, Moradabad, Noida **GUWAHATI:** Silchar, Tezpur **HYDERABAD:** Karimnagar, Warangal **INDORE:** Bhopal, Gwalior, Jabalpur, Rewa, Ujjain **J&K:** Kashmir, Srinagar **JAIPUR:** Bhilwara, Bikaner, Jodhpur, Kota, Sikar, Udaipur **KOLKATA:** Bankura, Bardhaman, Siliguri **LUCKNOW:** Gorakhpur, Prayagraj, Shahjhanpur, Varanasi **LUDHIANA:** Amritsar, Barnala, Jammu, Mansa **MADURAI:** Nagercoil, Rajapalayam **MUMBAI:** Aurangabad, Nasik **NAGPUR:** Akola, Amravati, Chandrapur **PUNE:** Goa, Nasik, Kolhapur, Sangali, Solapur **RAIPUR:** Ambikapur **RAJKOT:** Bhavnagar, Jamnagar **RANCHI:** Dhanbad, Muzaffarpur, Patna, Purnia, Siwan **SURAT:** Aurangabad, Nasik **VIJAYAWADA:** Chittoor, Rajahmundry, Tirupathi, Vishakhapatnam

WAREHOUSES

National Warehouse

NOIDA B-58, Sector-80, Phase-II, Noida, District Gautam Budh Nagar, Uttar Pradesh - 201305 INDIA
Ph.: +91 120 3857483/84/88/89

JHAJJAR P-12, Sector-3, Model Economic Township, Street No. 1, Badli, Dadri Toe
Jhajjar, Haryana - 124103 INDIA

