

We touch your **electricity** everyday!

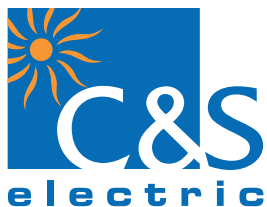

**GLOBAL SPECIALIST
FOR POWER BUSBARS**

Air Insulated Busbar System



metabar

Manufacturing Facilities



Greater Noida - India



Haridwar - India



Boom-Belgium

C&S Electric Ltd. a six decade established and one of the leading suppliers of electrical equipment in India. It's wide range of electrical and electronic products find application in power generation, distribution, control, protection and final consumption.

C&S employs over 4000 people including 400 engineers, and has 17 state-of-the-art manufacturing plants. It has 22 sales/marketing offices across India and its products are exported to more than 88 countries. C&S Electric also has joint venture with global leaders.

The Power Busbar Division of C&S founded four decade ago and has been meeting the evolving needs of power generating stations, process and manufacturing industries, infrastructure establishments, technological centers and real estate developments with its complete and fully tested product line of Busduct, Bustrunking and associated equipment.

The Eta-com group was founded in 1979 and ever since markets a full range of cast resin insulated busway systems. The concept which was already in use in the sixties in industrial installations is now in the third generation form. Due to the typical characteristics, the system guarantees the integrity of many projects world-wide, providing safe and maintenance free electrical power supplies in both Low Voltage and Medium Voltage installations. With the acquisition of Eta-com in December 2011, the co-operation between the two companies gives birth to a **Global Power Busbars Specialist**.



metabar range cover Sandwich Bustrunking, Air Insulated Bustrunking & Lighting Trunking.

Energy Saver: Bustrunking has lower impedance in comparison to cable and conventional busducts for the same application. Lower impedance means less energy lost during distribution and this translates into cost savings.

Flexible Distribution: Plug-in type arrangement at regular intervals or as per customer design provides efficient power distribution.

Less Space: Bustrunking system require less space for Installation in a building / industry as compared to conventional busduct and cable system, so optimum utilization of space.

Conserves Raw-materials & Produces less waste: Material and manpower used in busway is lower than cable & conventional busduct. It saves money on raw materials and create less waste by buying pre-engineered lengths of busway.

Reusable: Bustrunking system comes with provision of expansions, changes, replacement and reusing.

EB - Sandwich Type

Compliance of Standard	IEC 61439 (1&6)
Independent Certificate Authority	UL, ASTA, CPRI-India
Conductor Material & Ratings	Copper 800A ~ 5000A
Rate Operational Voltage (Ue)	1000 Volt, AC
Rated Impulse Withstand Voltate (Uimp)	12 KV (1.2/50 s)
Enclosure Material	Aluminium
Busbar Insulation	Multi layer Class - 'F' Insulation
Degree of Protection	IP 54/IP55 /IP65 /IP67
Fire Rating	240Min. (ISO 834) 55
Seismic Compliance	Zone -5
Section Jointing	Uniblock Joint
Plug - in Box	32~630A



CB-Compact Air Insulated Type

Compliance of Standard	IEC 61439 (1&6)
Independent Certification Authority	ASTA-UK, CPRI-India
Conductor Material & Ratings	Copper 125~2000A, Aluminium 200~ 1250A
Rated Operational Voltage (Ue)	1000 Volt, AC
Rated Impulse Withstand Voltage (Uimp)	12 KV (1.2/50 s)
Enclosure Material	G.I
Busbar Insulator	Class-F
Degree of Protection	IP 54 /55
Fire Rating	120 Min. (ISO 834)
Seismic Compliance	Zone-5
Section Jointing	Uniblock Joint
Plug in Box	32 ~ 400A



betobar is the leading technology in the world for cast resin insulated busbars in low & medium voltage installations.

This concept is unique as it is based on the direct encapsulation of copper or aluminium conductors with an insulation compound, B.I.M. casting mix, consisting of epoxy-resin mixed under vacuum. This B.I.M. casting mix has excellent electrical characteristics and high mechanical withstand with specific physical properties. It is moisture-resistant, fire-resistant and self extinguishing. A flexible fabrication method, universal moulds and an integrated process controlled mixing technique allow the production of an almost unlimited number of element forms for L.V as for M.V applications. The prefabricated elements are self-supporting and are interconnected electrically by joining the conductors with 2-sided compression contacts, ensuring an excess of contact surfaces and a maximum of adjustment. Junctions and element extremities are overcast with a B.I.M. casting mix resulting in a homogeneous insulation over the full length of the connection.

betobar busbars can be supplied in the following standard types:

For Low Voltage

LA-LB series
 Up to 1000 V AC / 1500V DC
 Three phase conductors and/or
 Protective earth / 50,100,150, 200% neutral

Al-conductors range up to 5200 A
 Cu-conductors range up to 6600 A

DC application on request
 Other frequencies on request

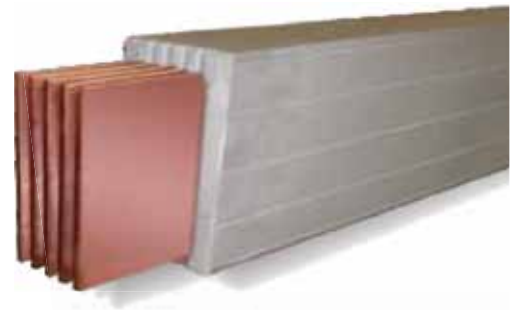

IP68

degree of protection

IK10

mechanical resistance

For Medium Voltage

Type	Current Rating	Voltage Rating
SH - Series	Al upto 1500 A	3.6 KV to 7.2 KV
	Cu upto 1850 A	
PH - Series	Al upto 5000 A	3.6 KV to 17.5 KV
	Cu upto 6100 A	

Other current and voltage ratings on request.



IP67

degree of protection



explosion proof on request

Isobar range covers Isolated Phase Busduct, Segregated Phase Busducts and Non-Segregated Phase Busducts.

C&S is a market leader in India and amongst the major global companies for design, manufacture, erection and commissioning of Isolated Phase Bus Ducts up to 1000MW power plants.

Today, we have an enviable track record of having associated with 14 Units of 660 MW, 25 Units of 500 MW, 35 Units of 250 MW, 30 Units of 150 MW Thermal Power Stations, Hydro Power Plants and Nuclear Power Plants, besides many Captive/Private Power Projects of capacity less than 100 MW. The largest proportion of power generated in India flows through C&S Isobar busducts.

Isobar Busduct have been successfully type tested for highest peak current during short circuit test and also for temperature rise test at world famous laboratories like KEMA-Holland and EDF-France, CPRI-Bhopal & Bangalore and at IIT-Roorkee (For Seismic tests).

Isolated Phase Busduct

C&S offers a wide range of natural air cooled Isolated Phase Busducts with voltage rating of 11kV to 38 kV having current rating of 100 A to 30,000 A, with the short circuit current withstand capacity of 312 kA / sec. & 844 kA peak. These Busducts have applications in all generating stations from 50 MW & above.



Segregated Phase Busducts

C&S offers a wide range of Segregated Phase Busducts for Medium Voltage applications from 3.3 kV to 33 kV upto 5000 A with a maximum Short Circuit Current withstand capability of 50 kA rms for 3 sec. and 128 kA peak. Segregated Phase Busducts find applications in power generating stations and industrial or distribution plants for lower capacity generator connections, inter-connections between switchgear and transformers.



Non-Segregated Phase Busducts

C&S offers a wide range of Non-Segregated Phase Busducts for Low Voltage applications from 415 V to 1.1 kV up to 6500 A with a maximum Short Circuit Current withstand capability of 80 kA RMS for 1 sec. and 180 kA peak. Non-Segregated Phase Busducts are commonly used in industrial utilities, power plants for interconnection between switchgear and transformers and also for lower capacity of generator (viz DG sets)



Other Products

- Non-Segregated Phase Busducts (415 to 1100V upto 6500A)
- DC Busbar Systems
- PTSP Cubicles
- Generator Auxiliary Compartments (GAC)
- Neutral Grounding Cubicles
- Line & Neutral Side Terminal Boxes
- Pressurization System for IPB's
- Hot Air Blowing Equipment

Compact Air Insulated

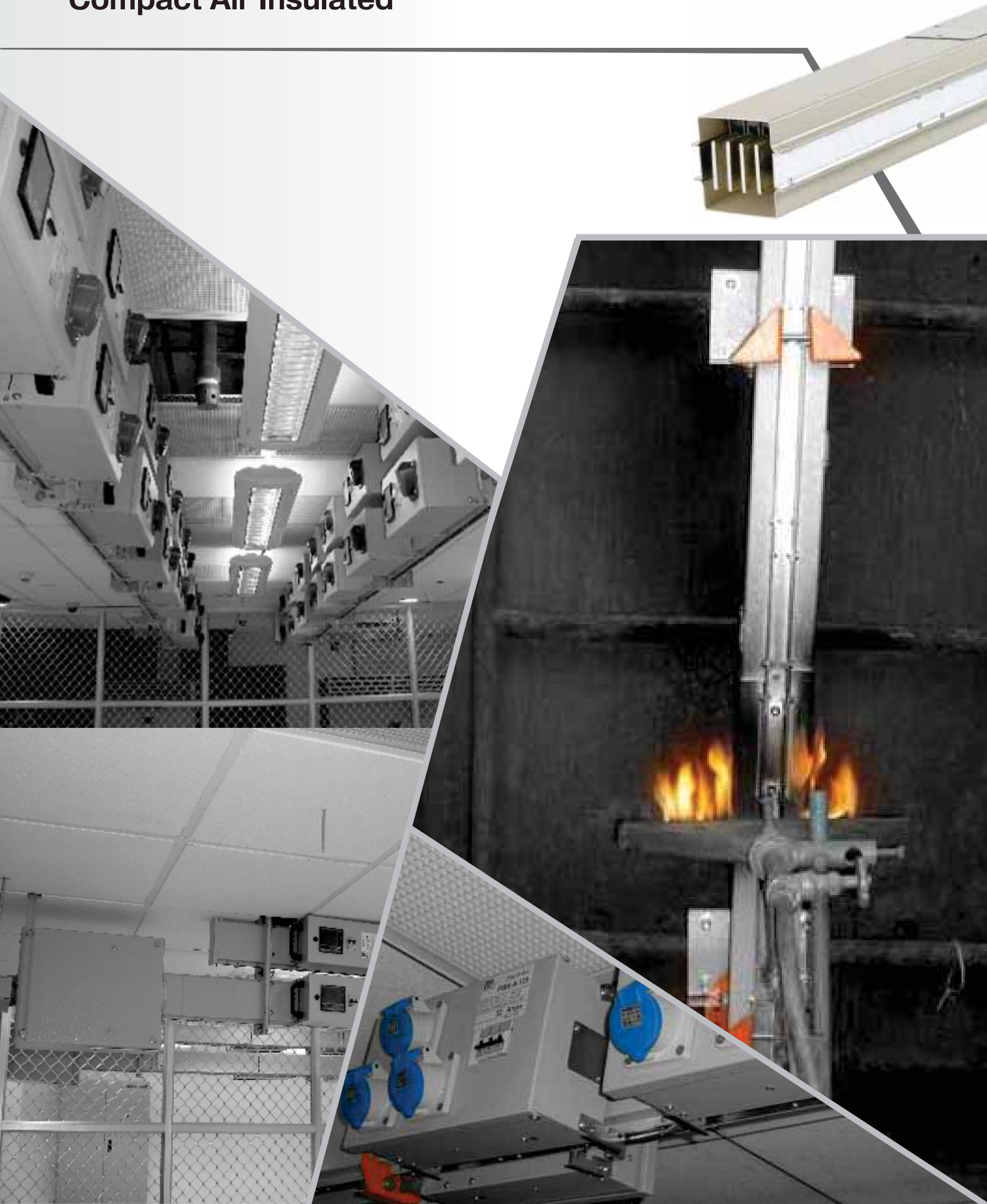

Applications



Technical Specifications

Air Insulated Busway

Compliance of Standard	IEC 61439 (1&6) & IS 8623 (1&2)
Independent Certification Authority	CPRI-India
Busbar Arrangement	Air Insulated type
Busbar Ratings	Copper 125 ~ 2000A Aluminium 200 ~ 1250A
	3 Phase+50% Integral Earth 3 Phase+100% Neutral+50% Integral Earth 3 Phase+200% Neutral+50% Integral Earth 3 Phase+100%Neutral+100% Isolated Earth+50%Integral Earth
Rated Operational Voltage (Ue)	1000 Volt, AC
Rated Insulation Voltage (Ui)	1000 Volt, AC
Rated Dielectric Voltage	2.5 KV r.m.s
Rated Impulse Withstand Voltage (Uimp)	12 kV (1.2/50 μ s)
Rated Frequency	50 Hz / 60 Hz
Enclosure Material	1.6 mm G.I
Surface Coating on Enclosure	Powder coated (RAL-7032)
Busbar Material (Phase/Neutral)	Copper (full round edge), 99.9% pure ETP grade Aluminium (full round edge), High strength & High conductivity
Busbar Material (Integral Earth)	1.5mm G.I / 1.5mm Copper (optional)
Busbar Material (External Earth)	Copper / Aluminium (optional)
Busbar Insulator	Glass Filled Polyester (Class -F)
Degree of Protection	IP 54
Fire Rating	120 Min.
Seismic compliance (IS:1893/IEEE693)	Zone-5
Plug -in-Box	32~400A

CBC (Copper Air Insulated Bus Trunking)

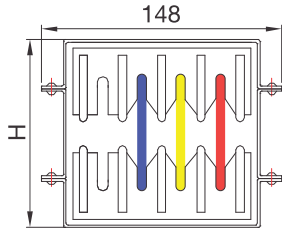

B | Y | R

3 Phase+50%
Integral Earth

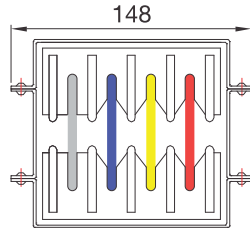

N | B | Y | R

3 Phase+100% Neutral
+50% Integral Earth

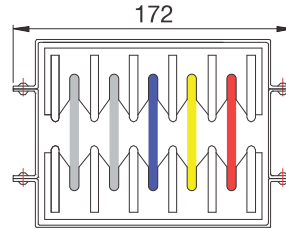

N | N | B | Y | R

3 Phase+200% Neutral
+50% Integral Earth

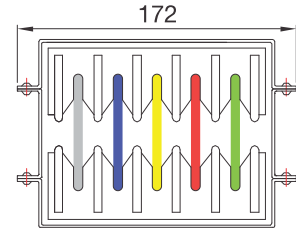

N | B | Y | R | E

3 Phase+100% Neutral
+100% Isolated Earth+50% Integral Earth

Rated Current (In)	Amps	125	315	400
Product Code		CBC 125	CBC 315	CBC 400
Busbar size per phase (No. of busbars)	mm	Dia 6.0	6x20(1)	6x30(1)
Overall Height (H)	mm	60	85	85
Rated Three Phase RMS Short Time Current for 1 Second (I _{cw})	kA	5	20	30
Rated Three phase Peak short time current (I _{pk})	kA	7.5	40	63
Rated Single Phase RMS Short Time Current for 1 Second (I _{cw})	kA	3	12	18
Rated Single phase Peak short time current (I _{pk})	kA	4.5	24	36
Approximate Weight of Bustrunking				
3 Phase + 50% Internal Earth	Kg/m	6.8	11.2	12.9
3 Phase + 100% Neutral + 50% Internal Earth	Kg/m	7.1	12.4	14.7
3 Phase + 200% Neutral + 50% Internal Earth	Kg/m	8.0	14.2	17.1
3 Phase+100% Neutral+100% Isolated Earth+50% Internal Earth	Kg/m	8.0	14.2	17.1
Electrical Characteristics for 50 Hz				
AC Resistance at 20°C (R ₂₀)	miliohms/mtr.	0.6346	0.1481	0.0987
A.C. Resistance at thermal conditions (R _t)	miliohms/mtr.	0.8092	0.1888	0.1259
Reactance (X)	miliohms/mtr.	0.1786	0.1250	0.1056
Impedance at thermal conditions (Z)	miliohms/mtr.	0.8287	0.2264	0.1643
Composite Voltage drop at Full Load concentrated at the end of bustrunking run (V)	mV/mtr./A at 0.7 P.F.	1.2020	0.3835	0.2832
	mV/mtr./A at 0.8 P.F.	1.3069	0.3915	0.2841
	mV/mtr./A at 0.9 P.F.	1.3964	0.3887	0.2759
	mV/mtr./A at 1.0 P.F.	1.4016	0.3270	0.2180
Electrical Characteristics for 60 Hz				
AC Resistance at 20°C (R ₂₀)	miliohms/mtr.	0.6348	0.1483	0.0989
A.C. Resistance at thermal conditions (R _t)	miliohms/mtr.	0.8219	0.1920	0.1281
Reactance (X)	miliohms/mtr.	0.2143	0.1500	0.1267
Impedance at thermal conditions (Z)	miliohms/mtr.	0.8494	0.2436	0.1801
Composite Voltage drop at full Load concentrated at the end of bustrunking run (V)	mV/mtr./A at 0.7 P.F.	1.2616	0.4183	0.3119
	mV/mtr./A at 0.8 P.F.	1.3616	0.4219	0.3091
	mV/mtr./A at 0.9 P.F.	1.4432	0.4125	0.2953
	mV/mtr./A at 1.0 P.F.	1.4236	0.3325	0.2218

Voltage Drop Calculation Formulae

$$\Delta V = k \times \sqrt{3} \times (R_l \cos \phi + X_l \sin \phi) \times I_B \times L$$

Where

ΔV is the composite voltage drop of the system (V);

R_l & X_l are the mean resistance and reactance value of the system (m Ω /mtr)

I_B is the actual load current of the circuit being considered (A);

L is the length of the system being considered (M);

$\cos \phi$ is the load power factor being considered;

k is the load distribution factor:

$k=1$, if full load is concentrated at the end of the busbar trunking run;
 $k=(n+1)/2n$, if the load is uniformly spread between n branches.

	500	630	800	1000	1250	1750	2000
	CBC 500	CBC 630	CBC 800	CBC 1000	CBC 1250	CBC 1750	CBC 2000
	6x40(1)	6x50(1)	6x70(1)	6x90(1)	6x50(2)	6x70(2)	6x90(2)
	85	95	115	135	190	230	270
	35	50	50	50	50	65	65
	73.5	105	105	105	105	143	143
	21	30	30	30	30	39	39
	44.1	63	63	63	63	81.9	81.9
	14.7	16.8	20.9	25.0	29.6	37.8	46.0
	17.1	19.7	25.0	30.3	35.4	46.0	56.6
	20.1	23.3	29.8	36.2	42.0	54.9	67.8
	20.1	23.3	29.8	36.2	42.0	54.9	67.8
	0.0740	0.0592	0.0429	0.0339	0.0296	0.0215	0.0169
	0.0944	0.0755	0.0548	0.0432	0.0378	0.0274	0.0216
	0.0792	0.0667	0.0524	0.0444	0.0342	0.0268	0.0227
	0.1232	0.1007	0.0758	0.0620	0.0509	0.0383	0.0313
	0.2124	0.1740	0.1312	0.1074	0.0880	0.0663	0.0543
	0.2131	0.1739	0.1303	0.1061	0.0878	0.0658	0.0535
	0.2070	0.1681	0.1249	0.1009	0.0847	0.0629	0.0508
	0.1635	0.1308	0.0948	0.0749	0.0654	0.0474	0.0374
	0.0742	0.0594	0.0431	0.0341	0.0298	0.0217	0.0171
	0.0961	0.0769	0.0558	0.0441	0.0386	0.0280	0.0222
	0.0950	0.0800	0.0629	0.0533	0.0410	0.0321	0.0272
	0.1351	0.1110	0.0841	0.0692	0.0563	0.0427	0.0351
	0.2340	0.1922	0.1454	0.1195	0.0975	0.0737	0.0606
	0.2319	0.1897	0.1427	0.1166	0.0961	0.0722	0.0590
	0.2215	0.1803	0.1345	0.1091	0.0911	0.0680	0.0551
	0.1664	0.1332	0.0967	0.0764	0.0668	0.0486	0.0384

CBA (Aluminium Air Insulated Bus Trunking)

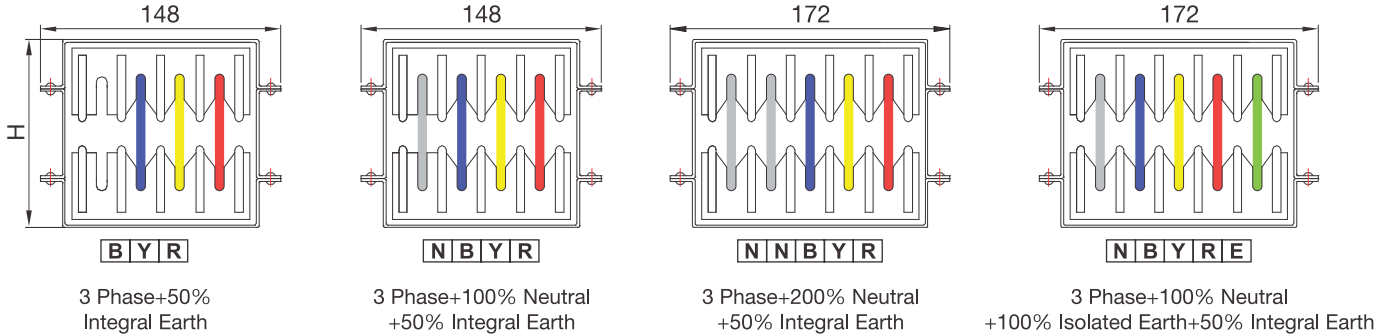

Rated Current (In)	Amps	200	250	315	
Product Code		CBA 200	CBA 250	CBA 315	
Busbar size per phase (No. of busbars)	mm	6x20(1)	6x30(1)	6x40(1)	
Overall Height (H)	mm	85	85	85	
Rated Three Phase RMS Short Time Current for 1 Second (I _{cw})	kA	10	15	25	
Rated Three phase Peak short time current (I _{pk})	kA	17	30	52.5	
Rated Single Phase RMS Short Time Current for 1 Second (I _{cw})	kA	6	9	15	
Rated Single phase Peak short time current (I _{pk})	kA	10.2	15.3	30	
Approximate Weight of Bustrunking					
3 Phase + 50% Internal Earth	Kg/m	8.7	9.3	9.8	
3 Phase + 100% Neutral + 50% Internal Earth	Kg/m	9.1	9.8	10.5	
3 Phase + 200% Neutral + 50% Internal Earth	Kg/m	10.1	11.0	11.9	
3 Phase+100% Neutral+100% Isolated Earth+50% Internal Earth	Kg/m	10.1	11.0	11.9	
Electrical Characteristics for 50 Hz					
AC Resistance at 20°C (R ₂₀)	Milohms/mtr.	0.2611	0.1741	0.1305	
A.C. Resistance at thermal conditions (R _t)	Milohms/mtr.	0.3335	0.2223	0.1667	
Reactance (X)	Milohms/mtr.	0.1250	0.1056	0.0792	
Impedance at thermal conditions (Z)	Milohms/mtr.	0.3561	0.2461	0.1846	
Composite Voltage drop at Full Load concentrated at the end of bustrunking run (V)	MV/mtr./A at 0.7 P.F.	0.5589	0.4001	0.3001	
	MV/mtr./A at 0.8 P.F.	0.5920	0.4177	0.3133	
	MV/mtr./A at 0.9 P.F.	0.6142	0.4263	0.3197	
	MV/mtr./A at 1.0 P.F.	0.5775	0.3850	0.2888	
Electrical Characteristics for 60 Hz					
AC Resistance at 20°C (R ₂₀)	Milohms/mtr.	0.2614	0.1744	0.1309	
A.C. Resistance at thermal conditions (R _t)	Milohms/mtr.	0.3390	0.2262	0.1697	
Reactance (X)	Milohms/mtr.	0.1500	0.1267	0.0950	
Impedance at thermal conditions (Z)	Milohms/mtr.	0.3707	0.2592	0.1945	
Composite Voltage drop at full Load concentrated at the end of bustrunking run (V)	MV/mtr./A at 0.7 P.F.	0.5966	0.4309	0.3233	
	MV/mtr./A at 0.8 P.F.	0.6257	0.4450	0.3339	
	MV/mtr./A at 0.9 P.F.	0.6418	0.4482	0.3363	
	MV/mtr./A at 1.0 P.F.	0.5872	0.3917	0.2940	

Voltage Drop Calculation Formulae

$$\Delta V = k \times \sqrt{3} \times (R_l \cos \phi + X \sin \phi) \times I_B \times L$$

Where

ΔV is the composite voltage drop of the system (V);

R_l & X are the mean resistance and reactance value of the system (m Ω /mtr)

I_B is the actual load current of the circuit being considered (A);

L is the length of the system being considered (M);

$\cos \phi$ is the load power factor being considered;

k is the load distribution factor:

$k=1$, if full load is concentrated at the end of the busbar trunking run;
 $k=(n+1)/2n$, if the load is uniformly spread between n branches.

	400	500	630	800	1000	1250
	CBA 400	CBA 500	CBA 630	CBA 800	CBA 1000	CBA 1250
	6x50(1)	6x70(1)	6x90(1)	6x50(2)	6x70(2)	6x90(2)
	95	115	135	190	230	270
	30	35	50	50	50	50
	63	73.5	105	105	105	105
	18	21	30	30	30	30
	36	44.1	63	63	63	63
	10.6	12.3	13.9	17.3	20.6	23.9
	11.5	13.5	15.5	19.1	23.1	27.1
	13.1	15.4	17.8	21.5	26.2	31.0
	13.1	15.4	17.8	21.5	26.2	31.0
	0.1044	0.0757	0.0598	0.0522	0.0379	0.0299
	0.1334	0.0967	0.0763	0.0667	0.0484	0.0382
	0.0667	0.0524	0.0444	0.0342	0.0268	0.0227
	0.1491	0.1100	0.0883	0.0749	0.0553	0.0444
	0.2442	0.1820	0.1475	0.1231	0.0918	0.0743
	0.2541	0.1884	0.1519	0.1279	0.0948	0.0765
	0.2583	0.1903	0.1525	0.1298	0.0956	0.0766
	0.2310	0.1675	0.1322	0.1155	0.0837	0.0661
	0.1047	0.0760	0.0601	0.0525	0.0382	0.0302
	0.1359	0.0986	0.0779	0.0681	0.0495	0.0392
	0.0800	0.0629	0.0533	0.0410	0.0321	0.0272
	0.1577	0.1169	0.0944	0.0795	0.0590	0.0477
	0.2637	0.1973	0.1604	0.1333	0.0998	0.0812
	0.2714	0.2020	0.1634	0.1370	0.1020	0.0826
	0.2722	0.2012	0.1618	0.1372	0.1015	0.0816
	0.2353	0.1708	0.1350	0.1180	0.0858	0.0678

Straight Length Feeder

- Transformer to Panel.
- Panel to Panel.
- Panel to Rising mains.

Standard Length: 3000mm
Maximum Length: 3000mm
Minimum Length: 500mm

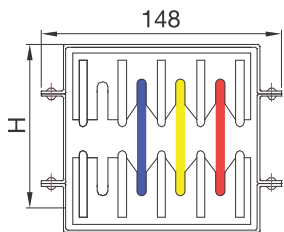

3 Phase+50%
Integral Earth

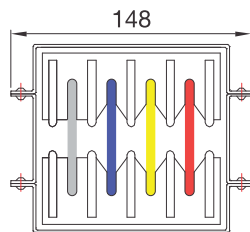

3 Phase+100% Neutral
+50% Integral Earth

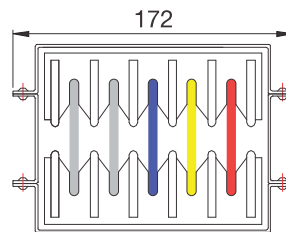

3 Phase+200% Neutral
+50% Integral Earth

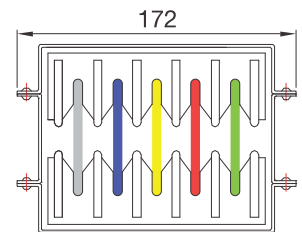

3 Phase+100% Neutral
+100% Isolated Earth+50% Integral Earth

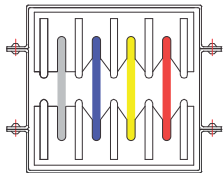

Copper 125~1000A
Aluminium 200~630A

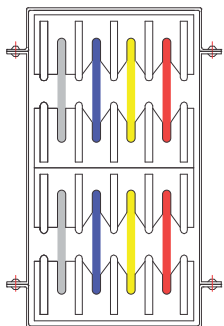

Copper 1250~2000A
Aluminium 800~1250A

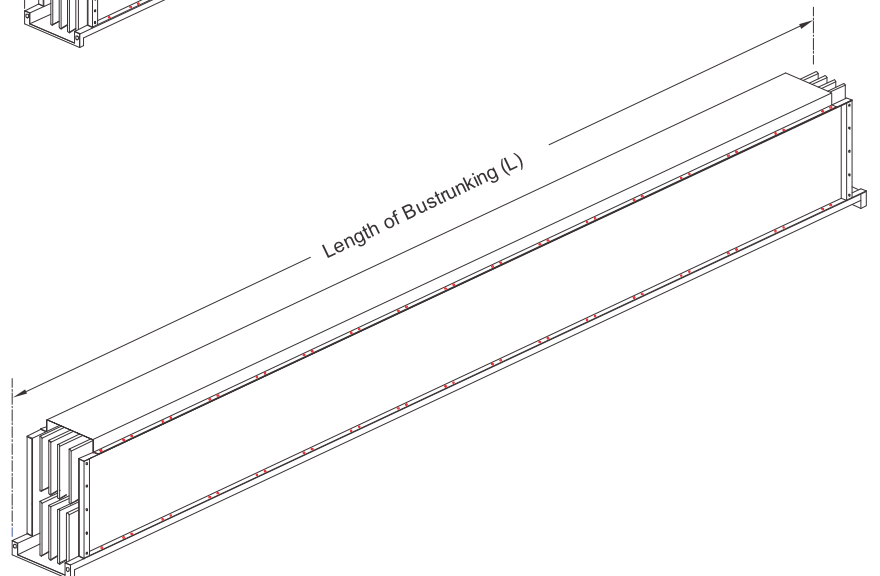
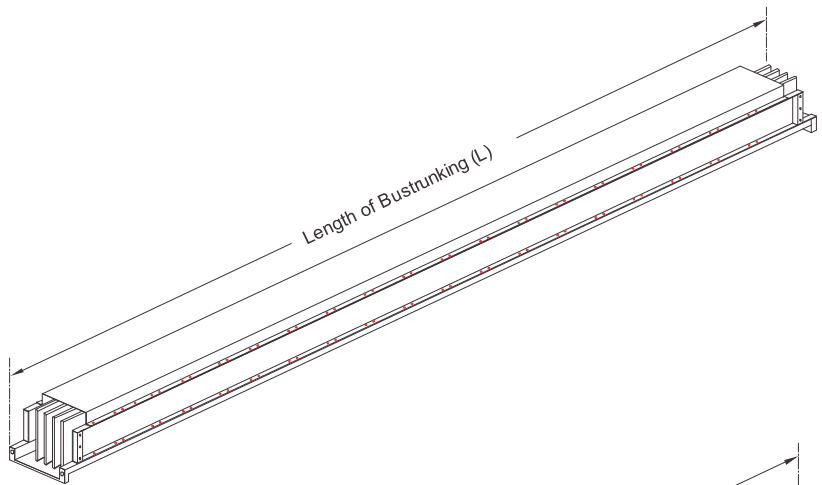

- For tapping Power from Main Line through Plug-in-Boxes. Horizontal Distribution / Vertical Distribution (Rising mains)
- Plug-in Points (PIP) are available at every 250 mm on alternate side (at every 500mm on either side)

Straight Length with PIP

Standard Length: 3000mm
 Maximum Length: 3000mm
 Minimum Length: 750mm

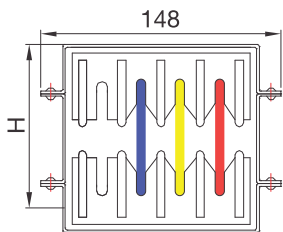

3 Phase+50%
Integral Earth

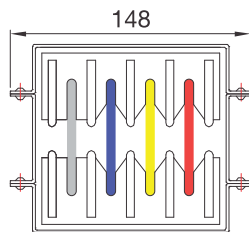

3 Phase+100% Neutral
+50% Integral Earth

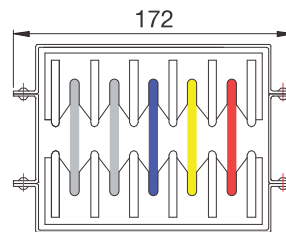

3 Phase+200% Neutral
+50% Integral Earth

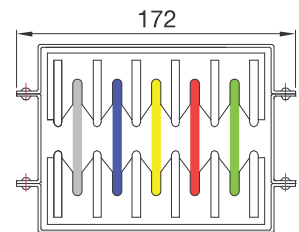

3 Phase+100% Neutral
+100% Isolated Earth+50% Integral Earth

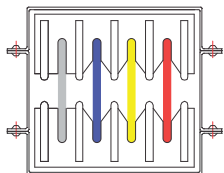

Copper 125~1000A
Aluminium 200~630A

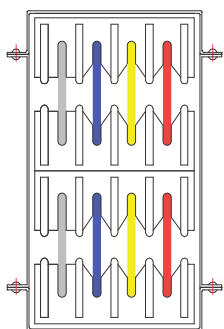
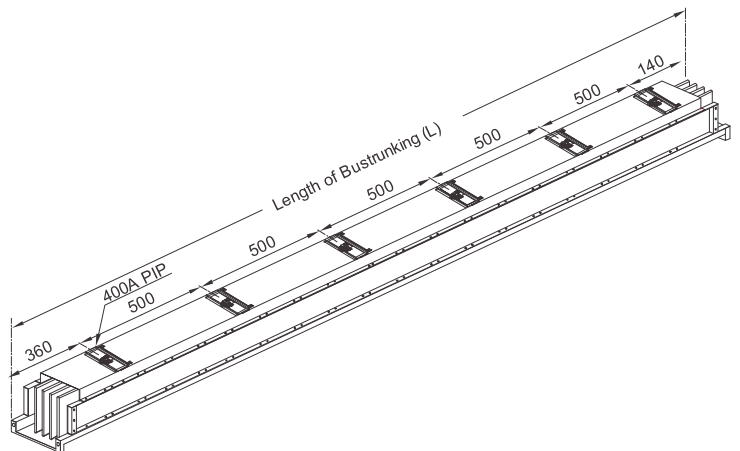

Copper 1250~2000A
Aluminium 800~1250A

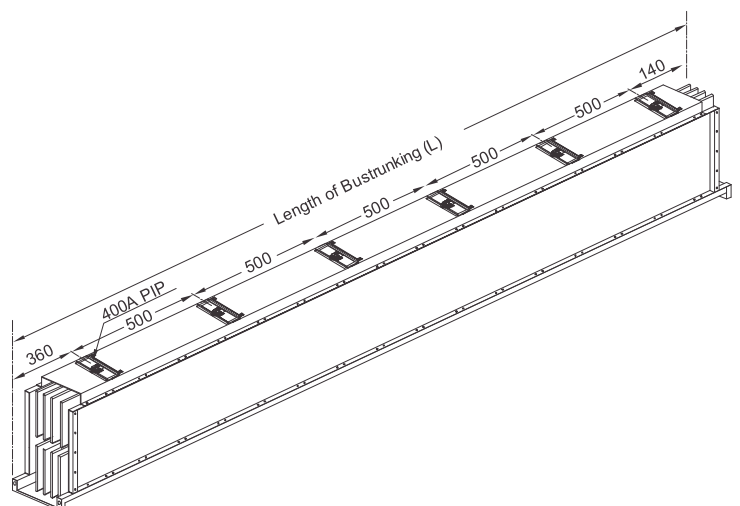

- Joint can be fitted / removed in installed condition without removal of section.
- Heavy duty disc spring used on both sides for uniform distribution of pressure.
- Joint can be tightened easily with help of spanner on nut side only. (spanner not required on bolt head side*)
- Shear off nut * ensure tightness of joint at desired torque and eliminates the need of torque wrench during installation.
- Tamper proof cap over shear off nut prevents opening of nut after achieving desired torque. Nut can only be opened after breaking the cap.

* Not applicable for CBC125 which has individual busbar connections.

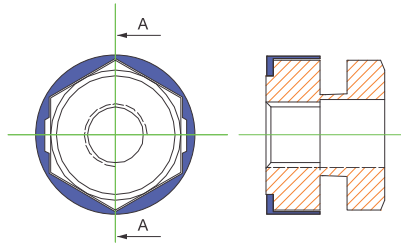

Shear off nut

Uniblock Joint

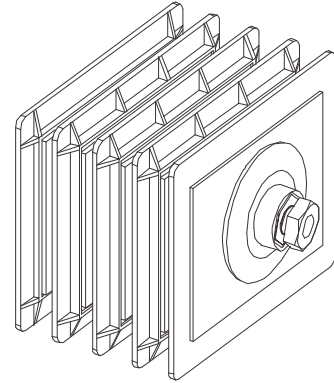

Edge Elbow

Current Rating	Standard Dimn. A x B (mm)	Minimum Dimn. A x B (mm)	Maximum Dimn. A x B (mm)
Copper - 125~2000A	500 x 500	300 x 300	750 x 750
Aluminium - 200~1250A	500 x 500	300 x 300	750 x 750

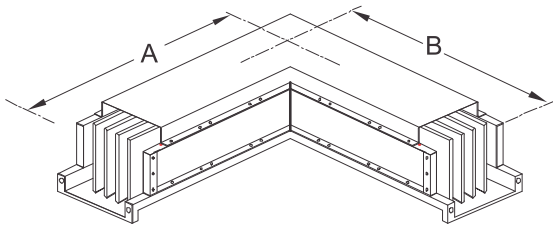

Type-1

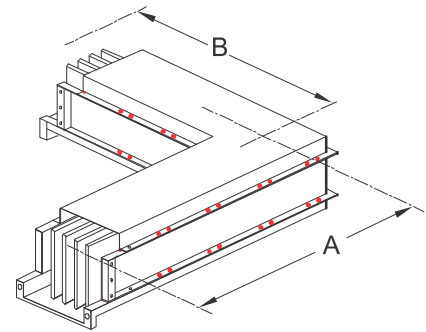

Type-2

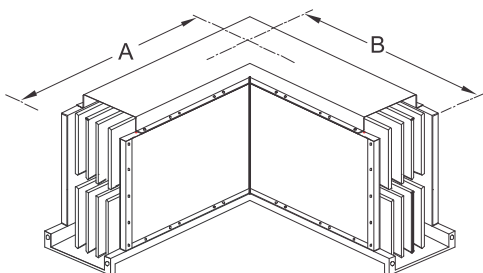

Type-1

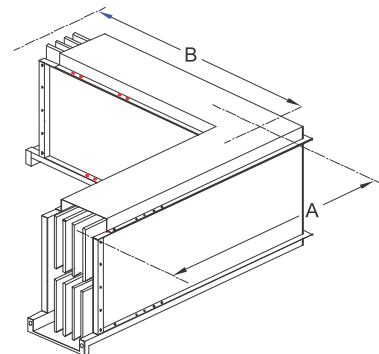

Type-2

Offset Edge Elbow

Current Rating	Standard Dimn. AxBxC (mm)	Minimum Dimn. AxBxC (mm)	Maximum Dimn. AxBxC (mm)
Copper - 125~2000A	500 x 500 x 500	300 x 300 x 300	450 x 600 x 450
Aluminium - 200~1250A	500 x 500 x 500	300 x 300 x 300	450 x 600 x 450

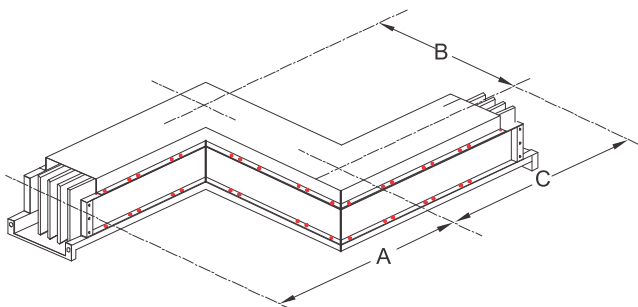

Type-1

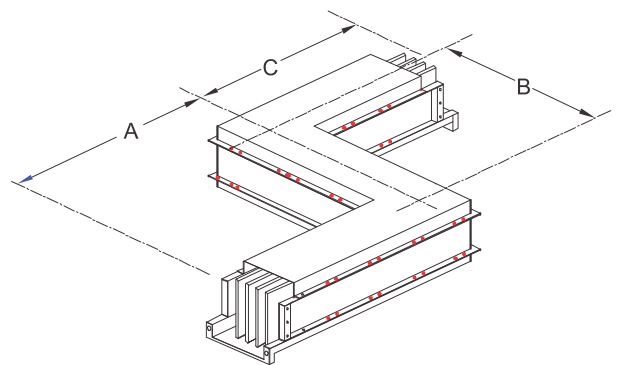

Type-2

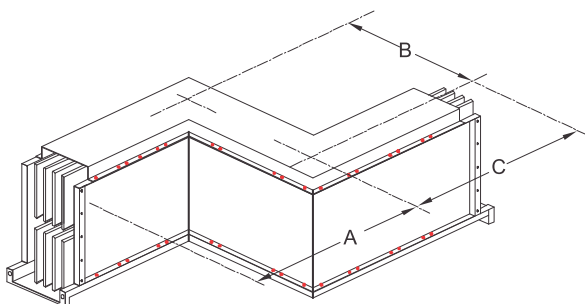

Type-1

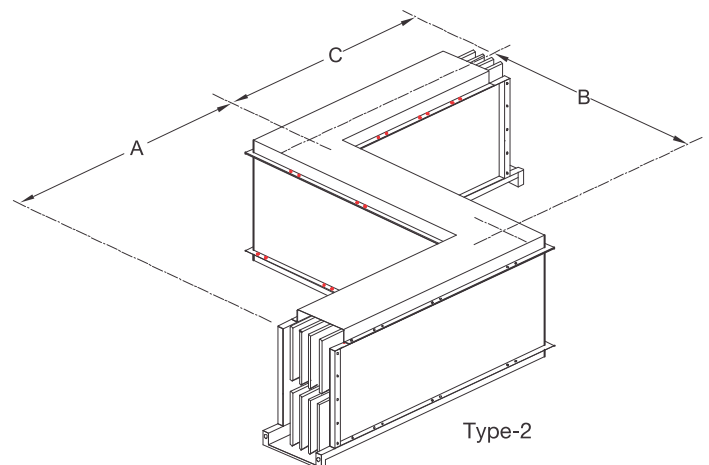

Type-2

Edge Tee

Current Rating	Standard Dimn. AxBxC (mm)	Minimum Dimn. AxBxC (mm)	Maximum Dimn. AxBxC (mm)
Copper - 125-2000A	500 x 500 x 500	500 x 500 x 500	750 x 750 x 750
Aluminium - 200-1250A	500 x 500 x 500	500 x 500 x 500	750 x 750 x 750

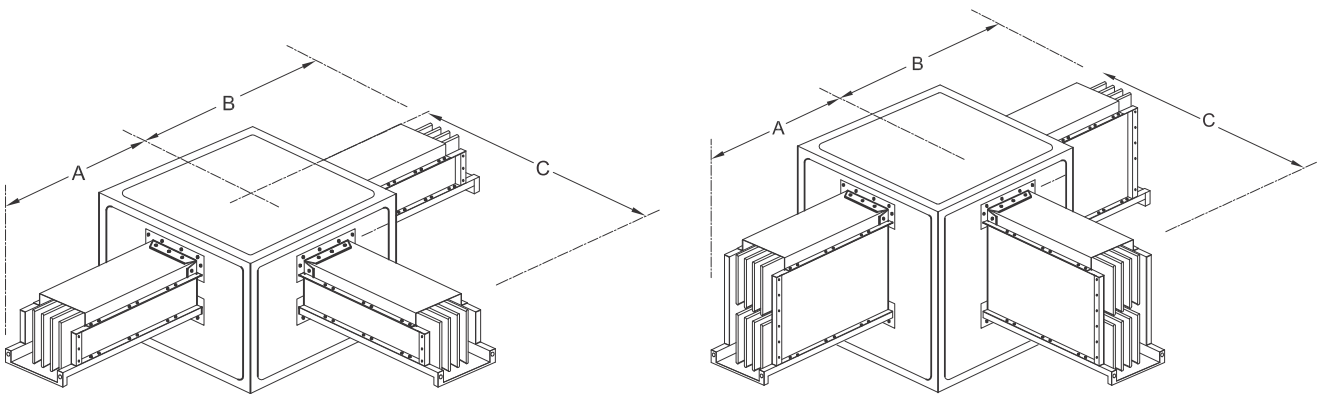

Current Rating	Standard Dimn. AxBxC (mm)	Minimum Dimn. AxBxC (mm)	Maximum Dimn. AxBxC (mm)
Copper - 125-2000A	500 x 500 x 500	500 x 500 x 500	500 x 500 x 500
Aluminium - 200-1250A	500 x 500 x 500	500 x 500 x 500	500 x 500 x 500

Flat Tee

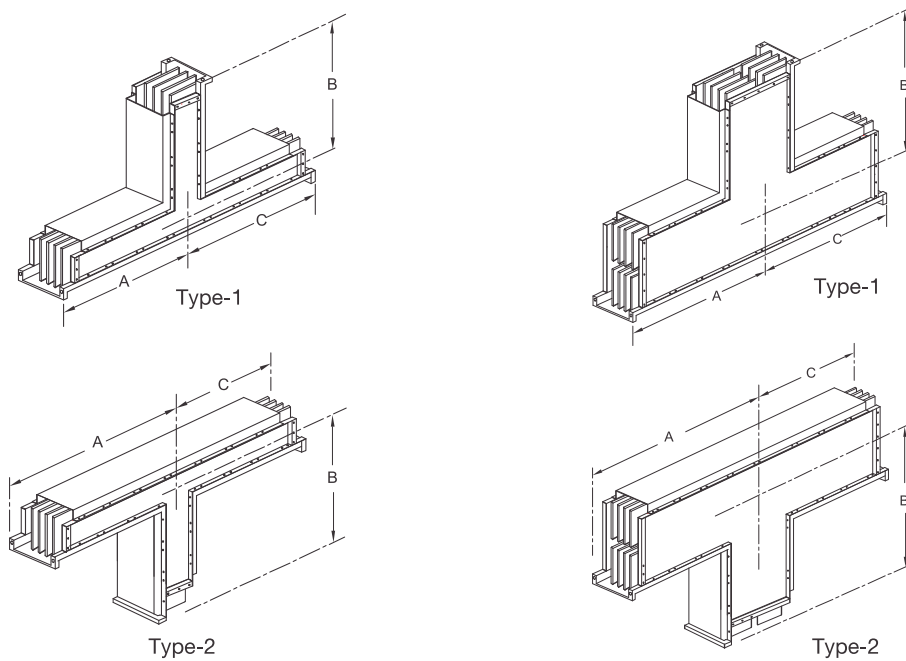

Flat Elbow

Current Rating	Standard Dimn. A x B (mm)	Minimum Dimn. A x B (mm)	Maximum Dimn. A x B (mm)
Copper - 125~2000A	500 x 500	300 x 300	750 x 750
Aluminium - 200~1250A	500 x 500	300 x 300	750 x 750

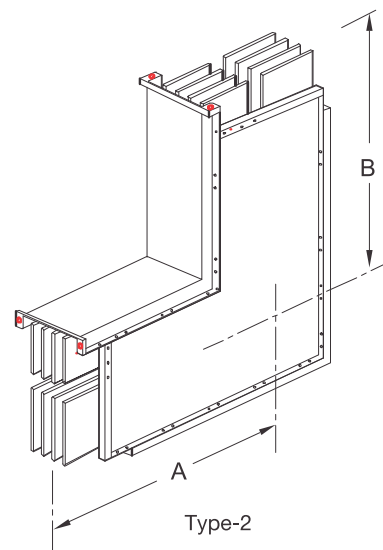
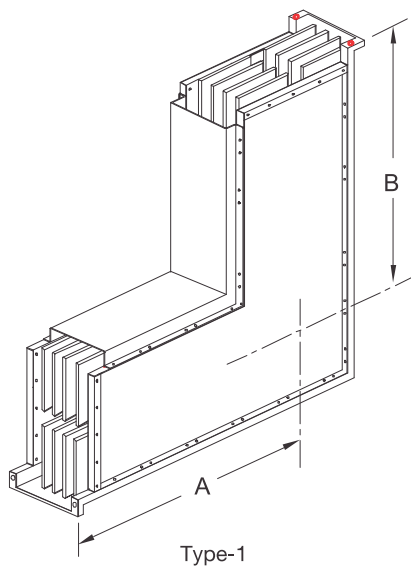
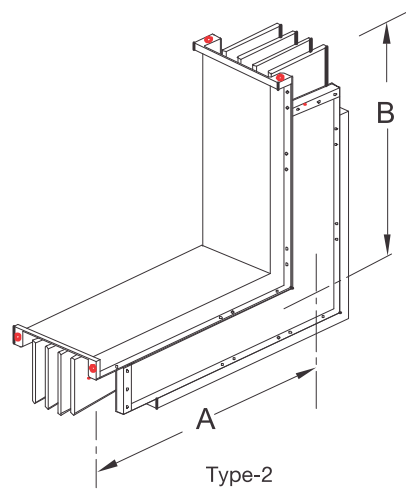
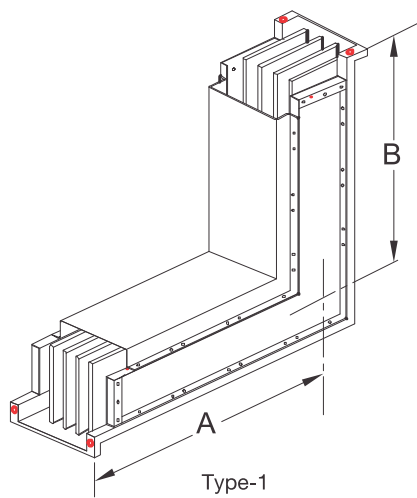

Offset Flat Elbow

Current Rating	Standard Dimn. AxBxC (mm)	Minimum Dimn. AxBxC (mm)	Maximum Dimn. AxBxC (mm)
Copper - 125~2000A	500 x 500 x 500	300 x 300 x 300	450 x 600 x 450
Aluminium - 200~1250A	500 x 500 x 500	300 x 300 x 300	450 x 600 x 450

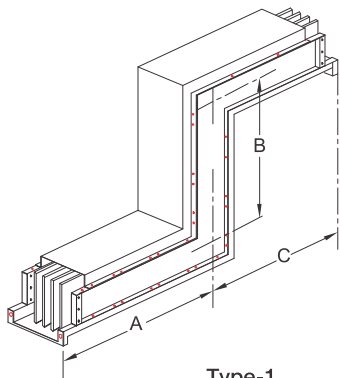

Type-1

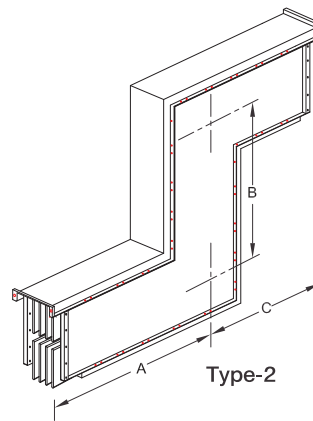

Type-2

Flanged End Box

Current Rating	Standard Dimensions		
	W	D	H
Copper - 125~1000A	500	250	250
Aluminium - 200~630A	500	250	250
Copper - 1250~2000A	500	350	250
Aluminium - 800~1250A	500	350	250

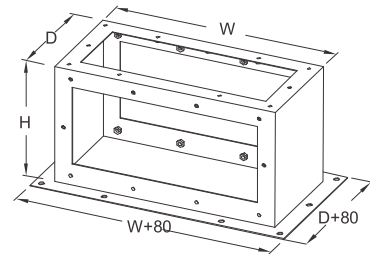

Flanged End Box Drilling Details

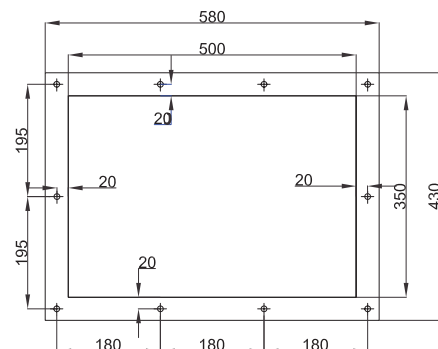
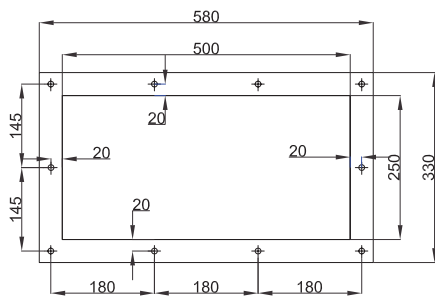

Flanged End

- Flanged End are required to connect Bustrunking run with panel or transformer directly through Flanged End Box.

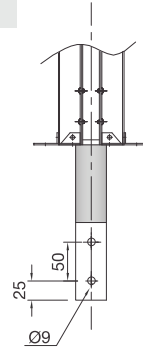
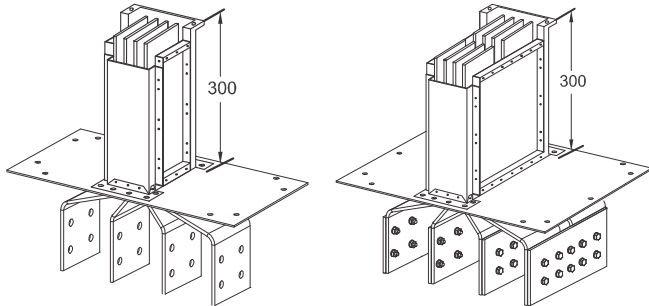

Figure -1
Busbar Width 20~30mm

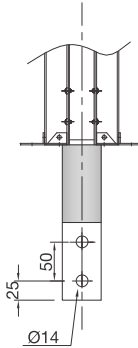

Figure -2
Busbar Width 40~70mm

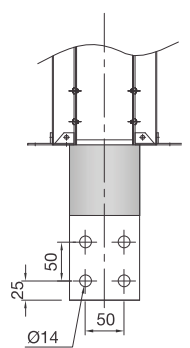
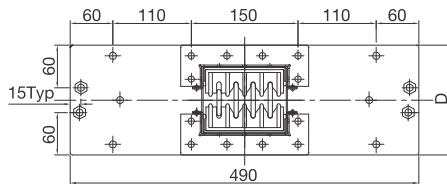
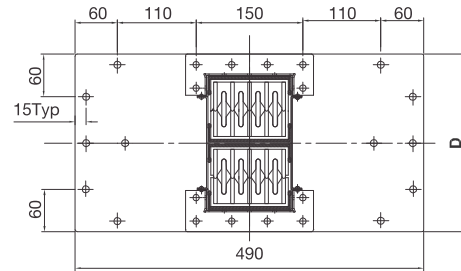

Figure -3
Busbar Width 90mm



Section X-X'



Section X-X'

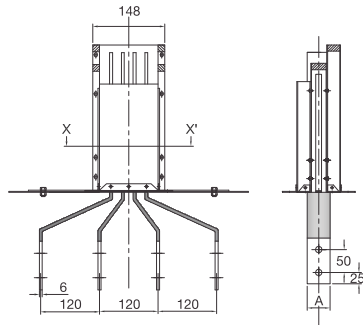

Figure - 4

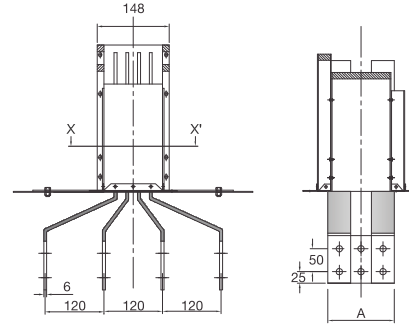

Figure - 5

Flanged End cut out & Drilling

Busbar size (No. Of Busbar)	Copper		Aluminium		Dimensions		Busbar Hole Details	Terminal Details
	Rating	Code	Rating	Code	D	A		
	125	CBC 125	-	-	120	-	-	Figure 4
20 x 6 (1)	315	CBC 315	200	CBA 200	145	20	Figure-1	
30 x 6 (1)	400	CBC 400	250	CBA 250	145	30	Figure-2	
40 x 6 (1)	500	CBC 500	315	CBA 315	145	40	Figure-2	
50 x 6 (1)	630	CBC 630	400	CBA 400	155	50	Figure-2	
70 x 6 (1)	800	CBC 800	500	CBA 500	175	70	Figure-2	
90 x 6 (1)	1000	CBC 1000	630	CBA 630	195	90	Figure-3	Figure 5
50 x 6 (2)	1250	CBC 1250	800	CBA 800	250	145	Figure-2	
70 x 6 (2)	1750	CBC 1750	1000	CBA 1000	290	185	Figure-2	
90 x 6 (2)	2000	CBC 2000	1250	CBA 1250	330	225	Figure-3	

Flanged End with Flat Elbow

Current Rating	Standard Dimn. AxB (mm)	Minimum Dimn. AxB (mm)	Maximum Dimn. AxB (mm)
Copper - 125~2000A	500 x 500	300 x 300	600 x 600
Aluminium - 200~1250A	500 x 500	300 x 300	600 x 600

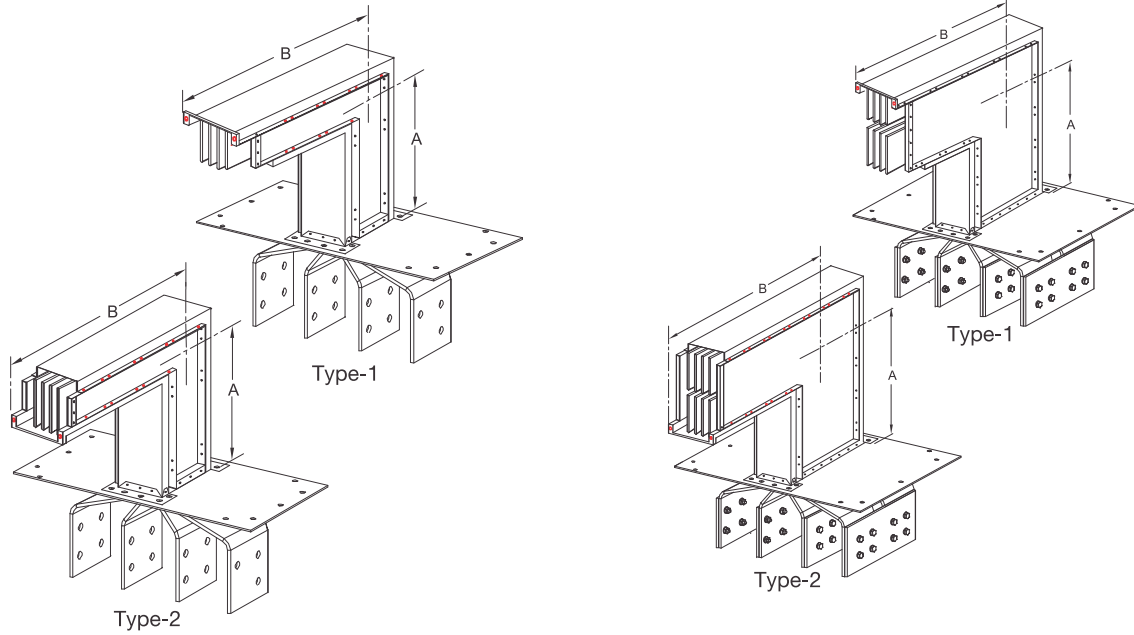

Flanged End with Edge Elbow

Current Rating	Standard Dimn. AxB (mm)	Minimum Dimn. AxB (mm)	Maximum Dimn. AxB (mm)
Copper - 125~2000A	500 x 500	175 x 300	600 x 600
Aluminium - 200~1250A	500 x 500	175 x 300	600 x 600

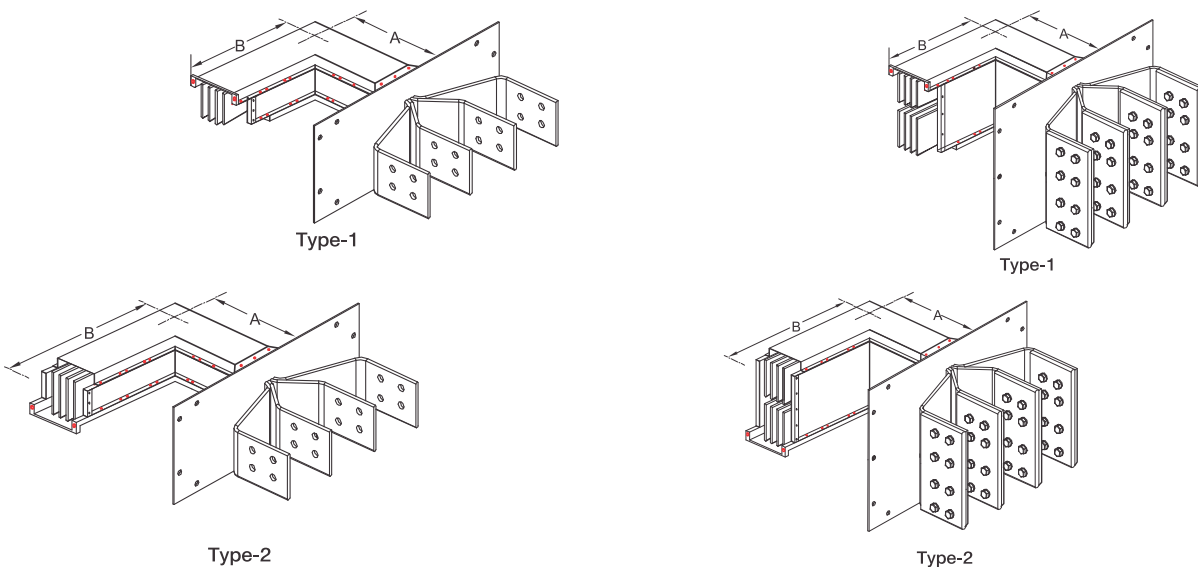

Reducer

- These are required to connect two dissimilar rating of busbar. Reducer may be designed with switching or isolating device.

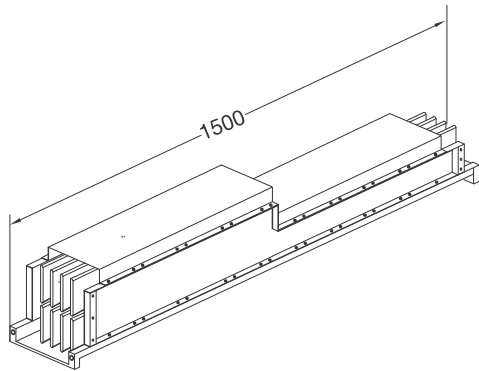

Reducer (Direct)

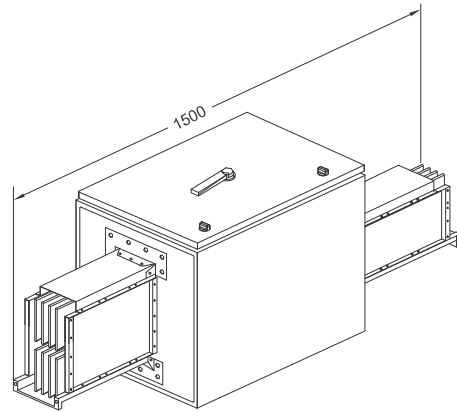

Reducer (Switchgear)

- These are required to isolate the busbar run in between, for various reasons. Section Isolator Unit can be fitted with load Break Switches / SFU's / MCCB's.

Sectional Isolator

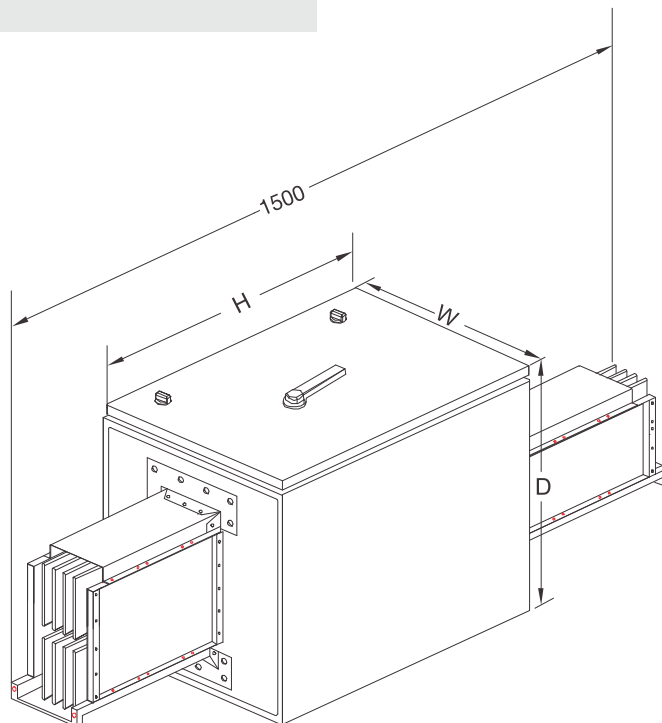

- To charge bustrunking through cables from one end of bustrunking.
- End feed is available with sufficient space for direct connection through lugs and bolts. MCCB, SFU, Isolators, fuse holders etc. can be fitted in End Feed as per requirement.
- 300 mm length of bustrunking is integrally fitted (measured with bustrunking) along with End Feed as standard practice so that joint between End Feed and bustrunking is exactly same as joint of two normal bustrunking lengths.
- Undrilled cable gland plate is provided at bottom for multiple cable entry.

End Feed

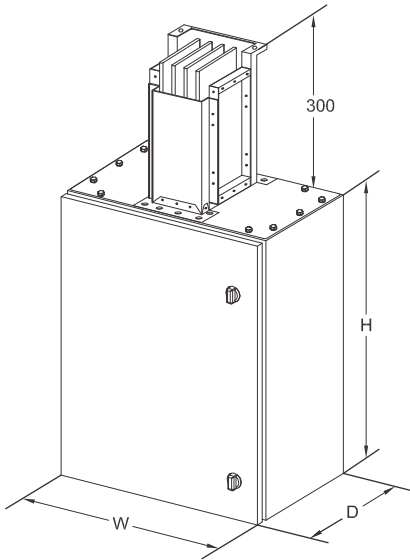

End Feed (Direct)

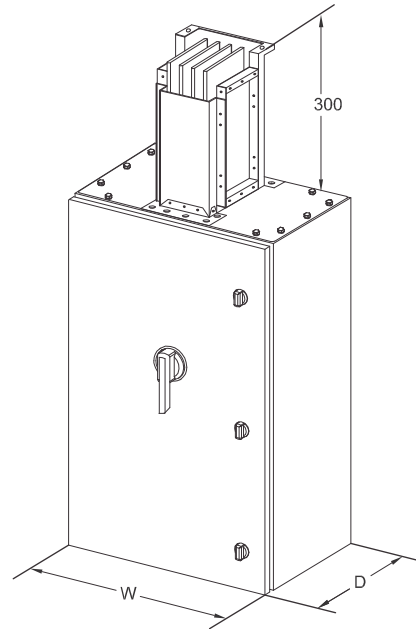

End Feed (Switchgear)

Code	Dimensions		
	H	W	D
CBC125 to CBC400 CBA200 to CBA400	400	400	250
CBC500 to CBC1000 CBA500 to CBA630	600	400	250
CBC1250 & CBA800 CBA1250	600	500	370
CBC1750 & CBC2000	800	500	370

Code	Dimensions		
	H	W	D
CBC125 CBA200 to CBA250	800	400	250
CBC315 to CBC630 CBA315 to CBA630	800	400	250
CBC800 CBA1000	800	500	370
CBC1250 to CBC2000 CBA800 to CBA1250	1000	500	370

Center Feed Unit

- Center Feed is required to charge bustrunking through cables at any position between two section of bustrunking
- Center feed Unit is available with sufficient space for direct connection through lugs and bolts. MCCB, SFU, Isolators, fuse holders etc. can be fitted in Center Feed as per requirement.
- Undrilled cable gland plate is provided at bottom for multiple cable entry.
- 300+300mm of bustrunking is inbuilt in centre feed for any easy connection to bustrunking sections both sides.

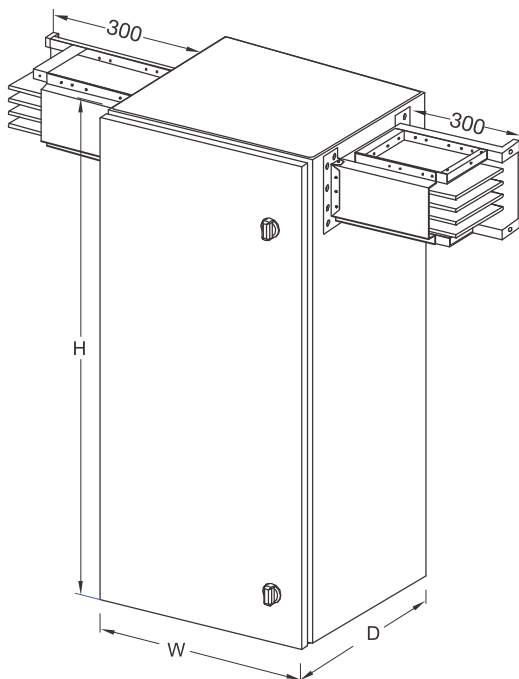

Center Feed Unit (Direct)

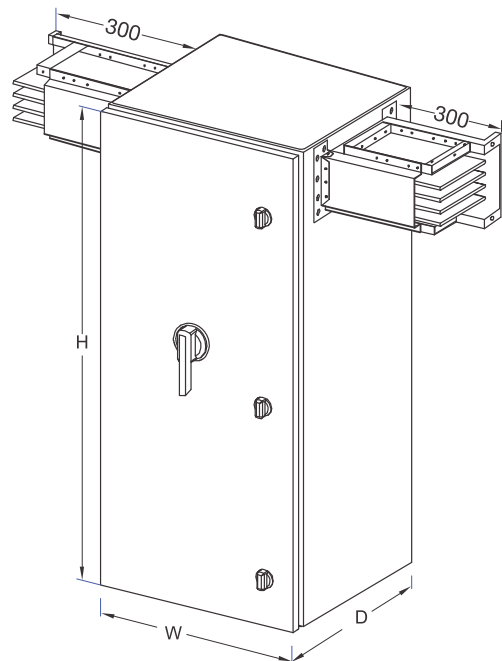

Center Feed Unit (Switchgear)

Code	Dimensions		
	H	W	D
CBC125 to CBC400	600	400	250
CBA200 to CBA400			
CBC500 to CBC1000	800	400	250
CBA500 to CBA630			
CBC1250 & CBA800	800	500	370
CBA1250			
CBC1750 & CBC2000	1000	500	370

Code	Dimensions		
	H	W	D
CBC125 to CBC400	800	400	250
CBA200 to CBA400			
CBC500 to CBC1000	800	400	250
CBA500 to CBA630			
CBC1250 & CBA2000	1000	500	370
CBA800 to CBA1250			

- Copper Flexible need to be used to connect flanged end busbar with busbars (Terminals) of Panel / Transformer / Generators.

Copper Flexible

- Standard Dimension (L) :- 350mm
- Minimum Dimension (L) :- 300mm
- Maximum Dimension (L) :- 400mm

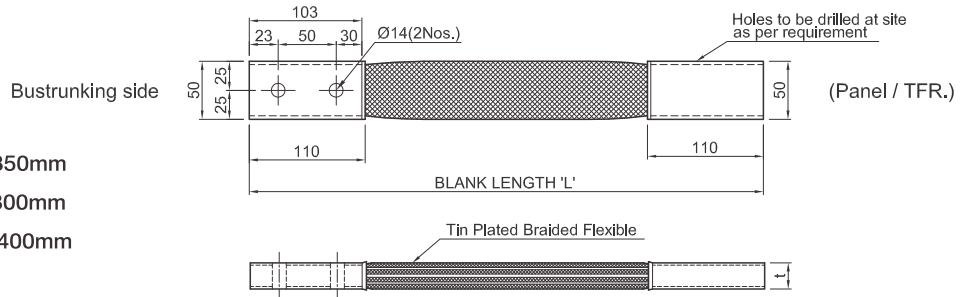

- It is used to close the end of plug-in bustrunking run.
- It can be removed easily for extension of bustrunking .

End Cover

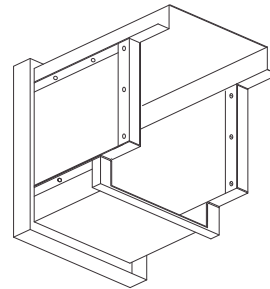

- It is required to support vertical bustrunking (Rising Main) through angle I channel support fitted on the wall.

Vertical Bracket

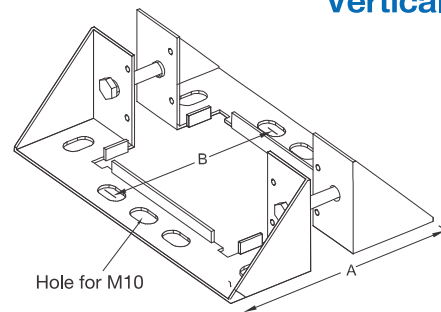

- It is required to support horizontal bustrunking (Horizontal Distribution) through angle I channel support fitted on the wall or ceiling.

Horizontal Bracket

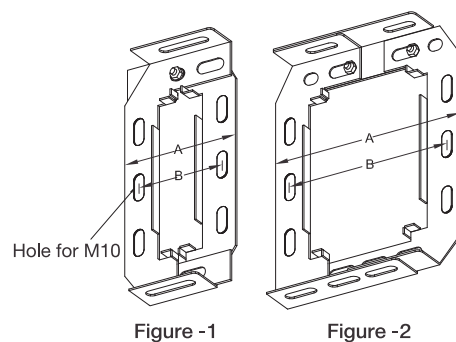

Expansion joint

- Expansion joint is provision provided in standard bustrunking section against specific requirement.
- Recommended to be used after continuous run of 50 mtrs.
- Standard Dimension (L) - 1500mm

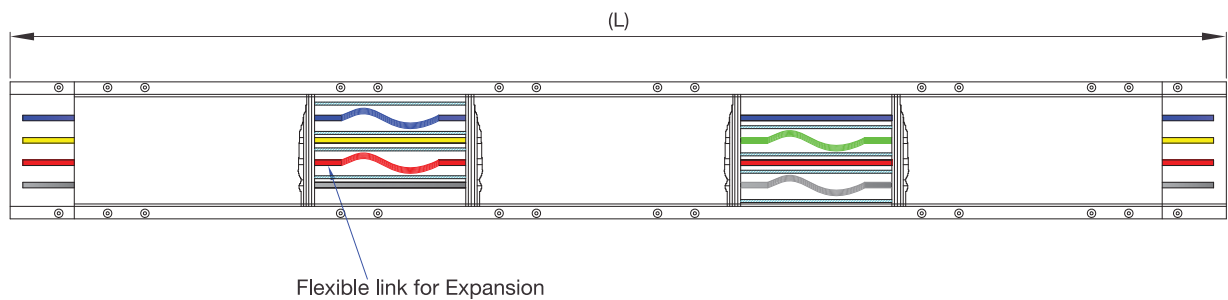

Fire Barrier

- Fire Barrier is provision provided in standard bustrunking section against specific requirement.
- Recommended to be used at each floor and wall crossing.
- Standard Dimension (L) - 1500mm

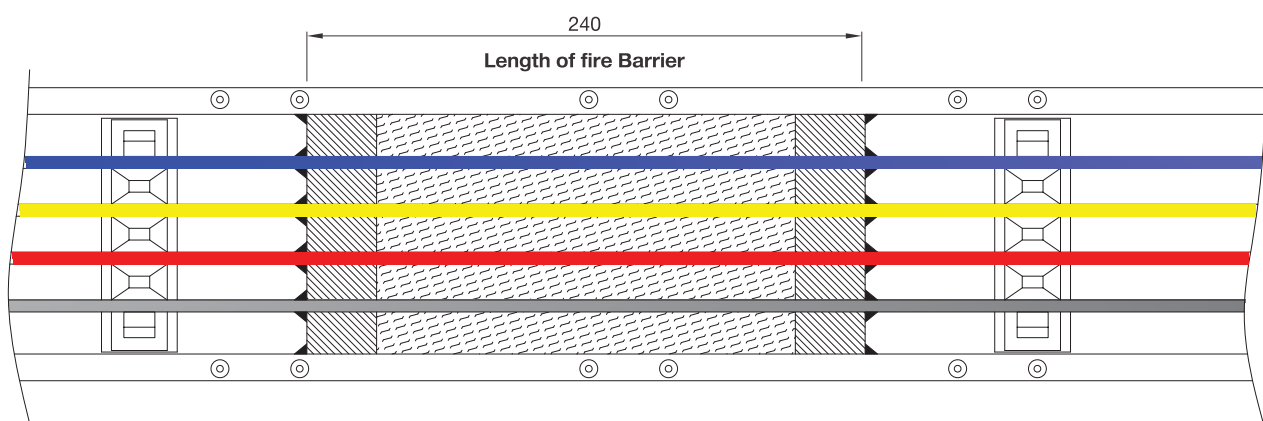

Phase Transposition Unit

- Phase transposition unit are used to change the relative position of the phase conductors in order to balance the inductive reactances or to transpose the phases (such as NRYB to BYRN)
- To be used only in indoor Application.

Standard Dimension (L) :- 1500mm

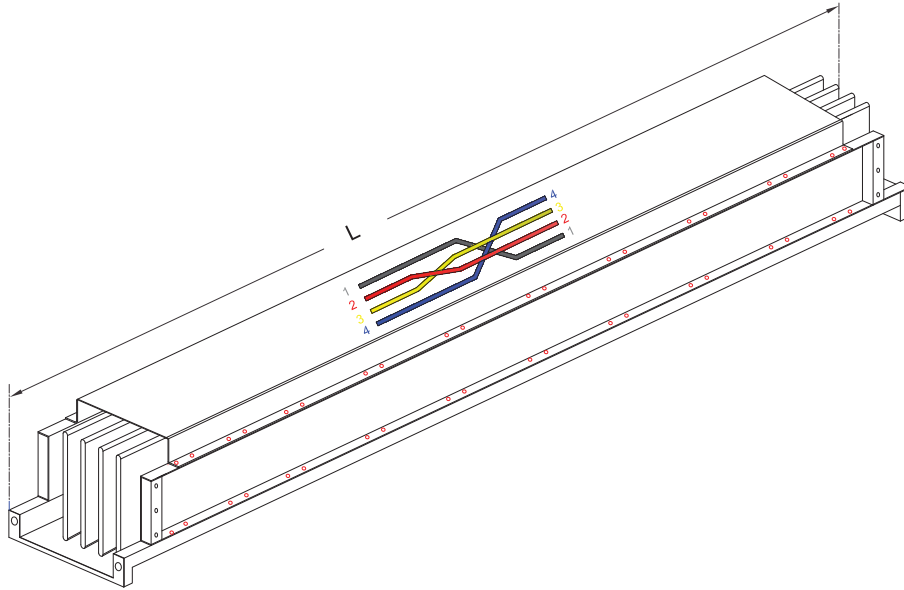

PHASE TRANSPOSITION UNIT (TYPE-3)

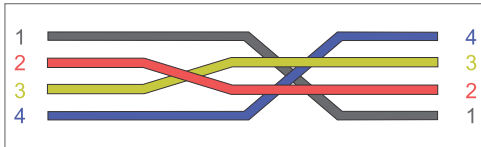

PHASE TRANSPOSITION UNIT (TYPE-2)

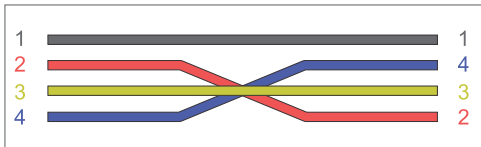

PHASE TRANSPOSITION UNIT (TYPE-1a)

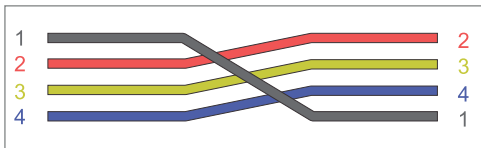

PHASE TRANSPOSITION UNIT (TYPE-1b)

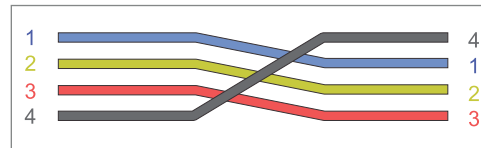

Note: One Element of 1500mm would be kept on hold if phase sequence is not known of any one side.

Plug-in-Box

- Plug in box enclosure is made from G. I with side hinged door.
- Plug in contacts are made out of Silver plated copper with spring steel backup pressure clips for ensuring uniform pressure and low contact resistance .
- For cables entry, provision of gland plates are provided on both sides and bottom of Plug in Box.
- Earth contact of Plug-in boxes makes first & breaks last.
- Plug in box can suitable for MCCB/SFU's with rotary handle and door interlocking.
- Plug in boxes are available with Interlocking with bustrunking to ensure "plug-in" and "Plug-Out" possible only in "Off" Condition.
- Silver Plated contacts are properly shrouded isolated.
- Plug in box up to 400 A are compatible to all ratings of Bustrunking with 400 A Plug-in-points
- Plug in boxes can only be fitted on to the Bustrunking with corrected polarity.

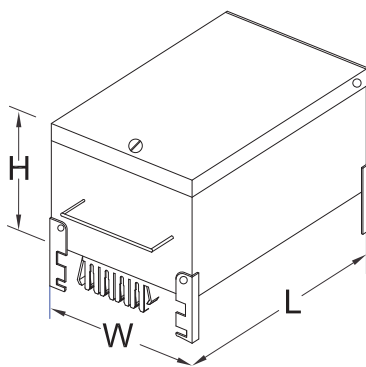

PIB X - S

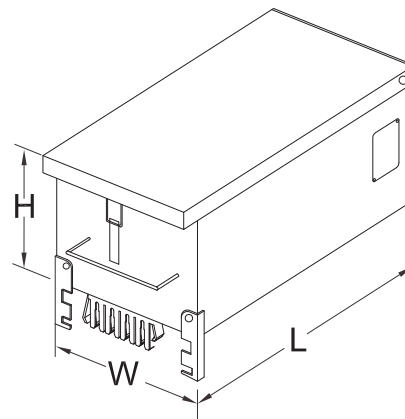

PIB X - A

PARAMTER	PIB X 'S' (4B)	PIB X 'S' (5B)	PIB X 'A' (4B)	PIB X 'A' (5B)
	Without Isolator		With Isolator	
With MCB / FUSES Provision	32A-63A		32A-125A	
With Socket-1 No. Provision	32A		63A	
With MCB+Socket-1 No. Provision	NA		32A-63A	
With MCCB without R/H Provision	NA		32A-125A	
With MCCB+R/H Provision	NA		NA	
With SFU Provision	NA		NA	
FINAL BOX SIZE (LXWXH)	280x180x100	280x204x100	410x180x124	410x204x124
Recommended Cable Size (Aluminium)	25 Sq.mm	25 Sq.mm	70 Sq.mm	70 Sq.mm

Plug-in-Box

- Plug in box enclosure is made from G. I with side hinged door.
- Plug in contacts are made out of Silver plated copper with spring steel backup pressure clips for ensuring uniform pressure and low contact resistance .
- For cables entry, provision of gland plates are provided on both sides and bottom of Plug in Box.
- Earth contact of Plug-in boxes makes first & breaks last.
- Plug in box can suitable for MCCB/SFU's with rotary handle and door interlocking.
- Plug in boxes are available with Interlocking with bustrunking to ensure "plug-in" and "Plug-Out" possible only in "Off" Condition.
- Silver Plated contacts are properly shrouded isolated.
- Plug in box up to 400 A are compatible to all ratings of Bustrunking with 400 A Plug-in-points
- Plug in boxes can only be fitted on to the Bustrunking with corrected polarity.

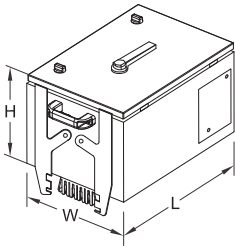

PIB X-N

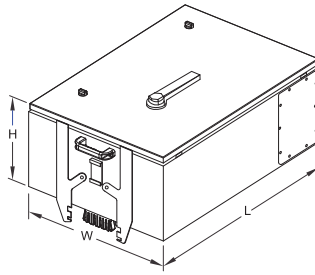

PIB X-B

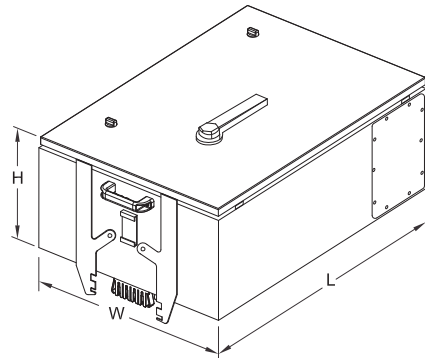

PIB X-C

PARAMTER	PIB X 'N' (4B)	PIB X 'N' (5B)	PIB X 'B' (4B)	PIB X 'B' (5B)	PIB X 'C' (4B)	PIB X 'C' (5B)
	Without Isolator		Without Isolator		Without Isolator	
With MCB / FUSES Provision	NA		NA		NA	
With Socket-1 No. Provision	NA		NA		NA	
With MCB+Socket-1 No. Provision	NA		NA		NA	
With MCCB without R/H Provision	NA		160A-250A		315A-400A	
With MCCB+R/H Provision	32A-125A		160A-250A		315A-400A	
With SFU Provision	32A-125A		160A-250A		315A-400A	
FINAL BOX SIZE (LXWXH)	430x300x200		500x300x250		600x400x250	
Recommended Cable Size (Aluminium)	70 Sq.mm	70 Sq.mm	150 Sq.mm	150 Sq.mm	2x150 Sq.mm	2x150 Sq.mm

Busway Route Planner

Customer : _____

Date : _____

Information required for quotation. Please, photocopy this form and attach to your inquiry.

In	Un	Freq.		Temp.		Project :					
A	V	Hz	t_0	t_{max}	$^{\circ}C$	$^{\circ}C$	Job no. :				
Conductors	3P	N	PE	+ -	Line	Length total	Outdoor	ΔU	%	Tap off's	
Cu <input type="checkbox"/> Al <input type="checkbox"/>	<input type="checkbox"/>	<input type="checkbox"/>	<input type="checkbox"/>	<input type="checkbox"/>	no.	m	m			In no.	

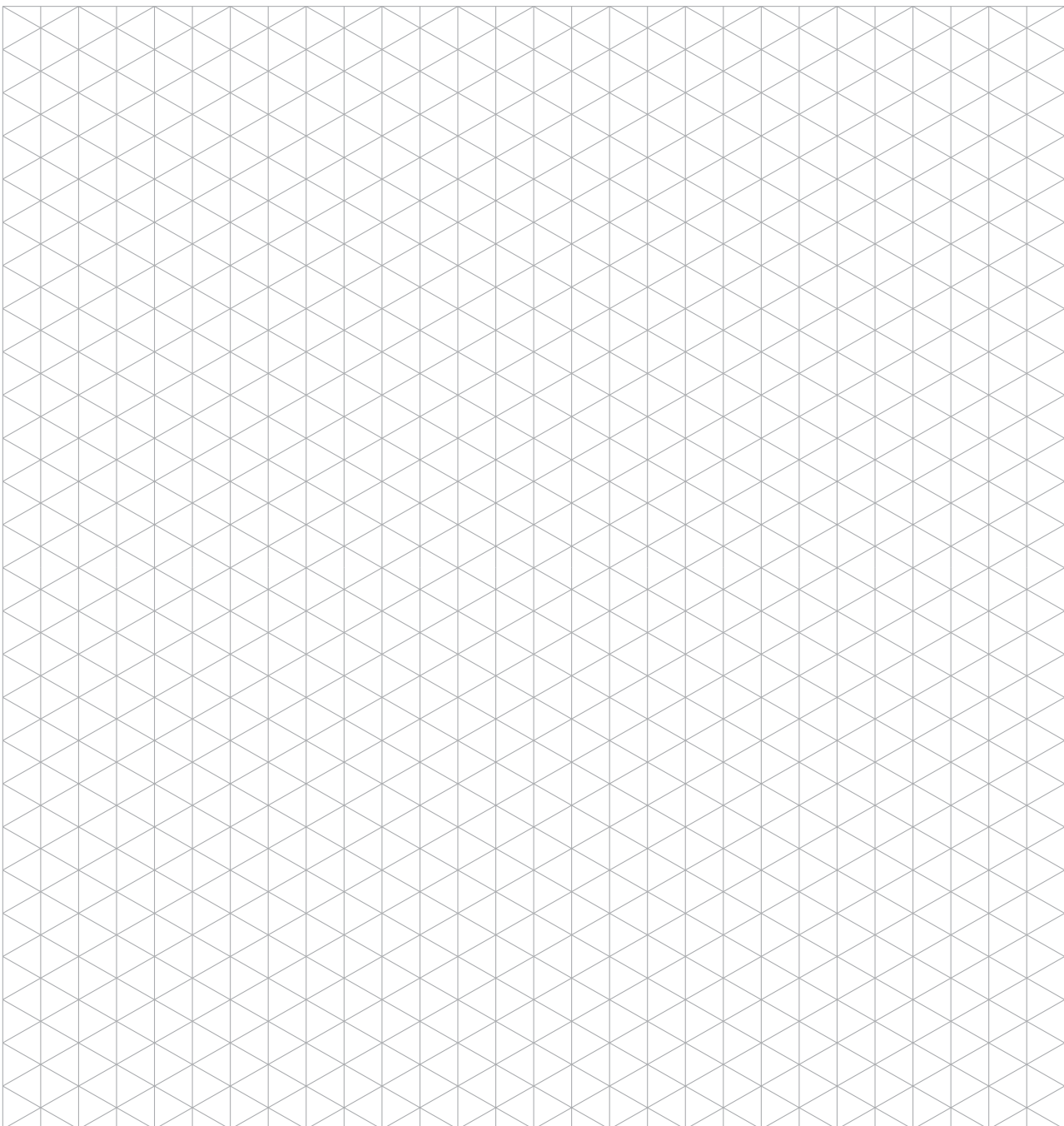

EARTHQUAKE ENGINEERING LABORATORY
EARTHQUAKE ENGINEERING & VIBRATION RESEARCH CENTRE
CENTRAL POWER RESEARCH INSTITUTE
Prof. Dr. C.V. Ramana Reddy, P. O. No. 6566, SANGALIGRE - 502 002 (INDIA)
Tele No. - 491 40 200/4853

CPRI
Sheet 1 of 14

TR No. EVRC-08/02/1112

TEST REPORT
EVRC EDL 02/1112 Date: 18.04.2011

Name & Address of the Customer: M/s. C & S Electric Limited, Bursurung Division, Plot No. 1A, Sector 1C, Integrated Industrial Estate, Rangpur, Rangpur - 240 402.

Name & Address of the Manufacturer: M/s. C & S Electric Limited, Bursurung Division, Plot No. 1A, Sector 1C, Integrated Industrial Estate, Rangpur, Rangpur - 240 402.

Particulars of the Sample Tested:
Condition of Sample on Receipt: New
Type: 550A, 1000V Air Insulated Supporting CBAS30 with steel ring main and 125A plug-in box.
Designation: —
Serial Number: —
Number of Samples Tested: One
Date(s) of Tests: 07.04.2011
CPRI Sample Code No.: EVRCSE/7011894
Particulars of Test Conducted: A) Resonance Seismic Test and B) Seismic Test
Test in accordance with Standard / Specification: IS 1503 (Part 1) - 2002, Zone V
Sampling Plan: Not applicable
Client's requirement: Nil
Deviation if any: Nil
Name of the Witnessing Person: Mr. A. Nadeem Khan
Client's representation: Nil
Other than customer's representation: Nil
Test subcontracted with address of the laboratory: Nil
Documents constituting this Report:
Number of Sheets (Total): Nil
Number of Photographs: Nil
Number of Graphs: Two
Number of Photos/Pictures: One
Number of Test Circuit Diagrams: Nil
Number of Drawings: Four

(J.P. PAMNER SELVAM) TEST ENGINEER
AUTHORISED SIGNATORY
(D.R. RAMAN) JOINT DIRECTOR
AUTHORISED SIGNATORY

CENTRAL POWER RESEARCH INSTITUTE
(Member of STL)
SWITCHGEAR TESTING & DEVELOPMENT STATION
GOVINDPURA, BHOPAL - 462 021, INDIA
Phone : 4910755, 258692, Fax : 4910753/2528774

CPRI
Certificate No. T-071
Sheet 1 of 5

TEST REPORT
Date: 10 FEB 2011

TR No. 1071071/1198

Name and Address of the Customer: M/s. C&S Electric Ltd, Bursurung Division, Plot No. 1A, Sector 1C, Integrated Industrial Estate (IIE), SICOIA, Rangpur (Bihar)

Name and Address of the Manufacturer: M/s. C&S Electric Ltd, Bursurung Division, Plot No. 1A, Sector 1C, Integrated Industrial Estate (IIE), SICOIA, Rangpur (Bihar)

Particulars of Sample(s) Tested: 1000V, 630A, Air Insulated Bursurung
Condition of Sample(s) on receipt: New
Type: Air Insulated Type
Designation: CBAS 300
Serial Number(s): Nil
Number of Sample(s) Tested: One
Date(s) of Test(s): 09/02/2011
CPRI Sample code number(s): DTDS ST 208 50001
Particulars of test(s) conducted: Lightning impulse voltage withstand test
Test in accordance with Standard Specification, Sampling Plan: Nil
Customer's Requirement: Nil
Deviation, if any: Nil
Name of the Witnessing person: Mr. Sankar Kumar Gupta, Sr. Manager, G.A.
Client's representation: Nil
Test subcontracted with name and address of the laboratory: NONE
Documents constituting this report (in words):
No. of Sheets: FIVE
No. of Photographs: SEVEN
No. of Graphs: Nil
No. of Photos/Pictures: Nil
No. of Test Circuit Diagrams: Nil
No. of Drawings: TWO

(D.R. RAMAN) TEST ENGINEER
AUTHORISED SIGNATORY
(S.K. GUPTA) JOINT DIRECTOR
AUTHORISED SIGNATORY

CENTRAL POWER RESEARCH INSTITUTE
SWITCHGEAR TESTING & DEVELOPMENT STATION
GOVINDPURA, BHOPAL - 462 021, INDIA
Phone : 4910755, 258692, Fax : 4910753, 28774

NABL ACCREDITED LABORATORY

TEST REPORT
Sheet 1 of 1

TR No. 1071071/1198
Date: 19 JAN 2009

Name and address of the Client: M/s. Corrota & Switchgear Co. Ltd, (Bursurung Division), Plot No. 1A, Sector 1C, Integrated Industrial Area, Kalyan Road, Greater Noida-201 200 (UP), India

Name and address of the Manufacturer: M/s. Corrota & Switchgear Co. Ltd, (Bursurung Division), Plot No. 1A, Sector 1C, Integrated Industrial Area, Kalyan Road, Greater Noida-201 200 (UP), India

Particulars of sample tested: 1000V, 630A, Bursurung (A) (Delux) Vole. shed. 3 of 5
Name: New
Type: Air insulated type
Condition of sample on receipt: New
Designation: CBAS-630
Serial Number: 50
No. of samples tested: One
CPRI Sample code number: DTDS ST 208 501209

Particulars of test conducted: Verification of the resistance of insulating medium to arcing test
Test in accordance with standard Specification: IEC 60479-2, 3000
Sampling plan: Not applicable
Client's requirement: Nil
Deviation if any: Nil
Name of the Witnessing person: Mr. Sankar Kumar Gupta Sr. Engr. GA
Client's representation: Nil
Test subcontracted with address of the laboratory: None
Documents constituting this report (in words):
Number of Sheets: FIVE
Number of Photographs: Nil
Number of Graphs: Nil
Number of Photos: Nil
Number of Test Circuit Diagrams: Nil
Number of Drawings: TWO

(R.S. RAJESH) TEST ENGINEER
AUTHORISED SIGNATORY
(S.K. GUPTA) JOINT DIRECTOR
AUTHORISED SIGNATORY

CENTRAL POWER RESEARCH INSTITUTE
SWITCHGEAR TESTING & DEVELOPMENT STATION
GOVINDPURA, BHOPAL - 462 021, INDIA
Phone : 4910755, 258692, Fax : 4910753, 28774

NABL ACCREDITED LABORATORY

TEST REPORT
Sheet 1 of 5
Date: 06 MAY 2005

TR No. 1020101/0219

Name and address of the Client: M/s. Corrota & Switchgear Co. Ltd, (Bursurung), Plot No. 1A, Sector 1C, Integrated Industrial Area, Kalyan Road, Greater Noida-201 200 (UP), India

Name and address of the Manufacturer: M/s. Corrota & Switchgear Co. Ltd, (Bursurung), Plot No. 1A, Sector 1C, Integrated Industrial Area, Kalyan Road, Greater Noida-201 200 (UP), India

Particulars of sample tested: 1000V, 630A, Air Insulated Bursurung (A) (Delux) Vole. shed. 3 of 5
Condition of sample on receipt: New
Type: Air Insulated Type
Designation: CBAS 630
Serial Number: Nil
No. of samples tested: One
Date(s) of Test(s): 05/04/2005 & 05/04/2005
CPRI Sample code number: DTDS ST 208 50001
Particulars of test conducted: Degree of protection IP-54
Test in accordance with standard Specification: IEC 60529 (IP-54) & IEC 60479 (10) 2500
Sampling Plan: Not applicable
Client's requirement: Nil
Deviation if any: Nil
Name of the Witnessing person: Mr. Sankar Kumar Gupta Sr. Engr. GA
Client's representation: Nil
Test subcontracted with address of the laboratory: None
Documents constituting this report (in words):
Number of Sheets: Six
Number of Photographs: Nil
Number of Graphs: Nil
Number of Photos: Nil
Number of Test Circuit Diagrams: Nil
Number of Drawings: TWO

(R.S. RAJESH) TEST ENGINEER
AUTHORISED SIGNATORY
(S.K. GUPTA) JOINT DIRECTOR
AUTHORISED SIGNATORY

CENTRAL POWER RESEARCH INSTITUTE
REGIONAL TESTING LABORATORY
3A, INSTITUTIONAL AREA, SECTOR - 42, NOIDA

CABLES LABORATORY

Page 1 of 1

TEST REPORT

01	Test Report No. & Date	CPRI/TLCC/2009/015	December 16, 2009
02	Name and Address of the Customer	M/s. C & S Electric Ltd., Plot 1A, Sector 42-11E, Bangpur, Ghaziabad, Uttar Pradesh.	
03	Customer's reference and date	Letter No. 74 dated 23.11.2009	
04	Name and Address of the Manufacturer	M/s. C & S Electric Ltd., Plot 1A, Sector 42, 11E, Bangpur, Ghaziabad, Uttar Pradesh.	
05	Particulars of apparatus tested (Description (if acceptable) - Name plus details)	400V, 50Hz 1000V 1U/1L, 30 Hr. Copper Air Insulated Bus-making system incorporating one joint and straight length section comprising three phase overhead and lateral path copper-roofed edge bus bar in galvanneal steel (G.L.) sections. Designation: CBI-400 Drawing No. C-CR/2206/0 C-CR/2206/014	
06	CPRI Code No.	CPRI/TLCC/2009/015 - 01, 015 - 02 & 015 - 03	
07	Condition of sample on receipt	Good	
08	Date of receipt	25.11.2009 to 24.11.2009	
09	No. of samples tested	Three	
10	Particulars of ISIRI/ASTM standard	Verification of specimens to <i>Bus preparation</i>	
11	Test in accordance with standard specification	As per IS: 4026/2 (Clause 8.2.10 and IS: 4022)	
12	Names of the witnessing persons of Test's representative (Other than Client's representative)	Mr. Abin Nandan Khan (SI)	
13	Document constituting this report (in words)	Number of pages: Five Number of photographs: Nil Number of drawings: Two Number of circuit diagrams: Nil Number of graphs: Nil Number of photos: Six	

(Signature)
JOINT ENGINEER

CPRI

Central Power Research Institute
(Member of STL)
REGIONAL TESTING & DEVELOPMENT STATION
GOVINDPURA, BHOPAL-462022, INDIA
Phone: +910755 230482 Fax: +910755 230774

CPRI

TEST REPORT

Page 1 of 1

Test Report Number: 0070206

Date: 16/12/09

Name & address of the Customer: M/s. C & S Electric Ltd. (Manufacturing Division), Plot No. 1A, Sector - 42, Integrated Industrial Estate (IIE), Bangpur, Ghaziabad (U.P.)

Name & address of the Manufacturer: M/s. C & S Electric Ltd. (Manufacturing Division), Plot No. 1A, Sector - 42, Integrated Industrial Estate (IIE), Bangpur, Ghaziabad (U.P.)

Particulars of sample tested: Air Insulated Supporting System

Condition of sample on Receipt: New

Type: Air Insulated

Designation: IAC-210 (Medium Voltage)

Serial number: Nil

Number of samples tested: One

Number of Tests: 25 (Primary, 20 in CPRI sample code in)

CPRI sample code in: 0700572100012

Particulars of tests conducted: Verification of the steel rod withdrawal strength

Test in accordance with: As per IS:2123 of IS: 4045/2, 2009

Sampling plan: Not applicable

Customer's representative: Nil

Witnesses if any: Nil

Name of the Witnessing persons: Mr. Gokul Kumar Gupta (SI, Manager G.L.)

Customer's representative: Nil

Other than Customer's representative: Nil

Test conducted at the address of the laboratory: Bangpur

Documents constituting this report (in words):

Number of photos: Five

Number of drawings: Two

Number of graphs: Nil

Number of photos: Five

Number of Test circuit diagrams: Two

Number of drawings: Two

(Signature)
JOINT ENGINEER

CPRI

Central Power Research Institute
(Member of STL)
REGIONAL TESTING & DEVELOPMENT STATION
GOVINDPURA, BHOPAL-462022, INDIA
Phone: +910755 230482 Fax: +910755 230774

CPRI

TEST REPORT

Page 1 of 1

Test Report Number: 0070209

Date: 16/12/09

Name & address of the Customer: M/s. C & S Electric Ltd. (Manufacturing Division), Plot No. 1A, Sector - 42, Integrated Industrial Estate (IIE), Bangpur, Ghaziabad (U.P.)

Name & address of the Manufacturer: M/s. C & S Electric Ltd. (Manufacturing Division), Plot No. 1A, Sector - 42, Integrated Industrial Estate (IIE), Bangpur, Ghaziabad (U.P.)

Particulars of sample tested: Air Insulated Supporting System

Condition of sample on Receipt: New

Type: Air Insulated

Designation: IAC-210 (Medium Voltage)

Serial number: Nil

Number of samples tested: One

Number of Tests: 25 (Primary, 20 in CPRI sample code in)

CPRI sample code in: 0700572100015

Particulars of tests conducted: Verification of the steel rod withdrawal strength

Test in accordance with: As per IS:2123 of IS: 4045/2, 2009

Sampling plan: Not applicable

Customer's representative: Nil

Witnesses if any: Nil

Name of the Witnessing persons: Mr. Gokul Kumar Gupta (SI, Manager G.L.)

Customer's representative: Nil

Other than Customer's representative: Nil

Test conducted at the address of the laboratory: Bangpur

Documents constituting this report (in words):

Number of pages: Five

Number of photographs: Nil

Number of drawings: Two

Number of graphs: Nil

Number of photos: Five

Number of Test circuit diagrams: Two

Number of drawings: Two

(Signature)
JOINT ENGINEER

CPRI

ASTA

CERTIFICATE OF SELECTED TYPE TESTS

Laboratory Ref. No. 0007111

Certificate No. 000000

APPARATUS: 400V, 50Hz 1000V 1U/1L, 30 Hr. Copper Air Insulated Bus-making system incorporating one joint and straight length section comprising three phase overhead and lateral path copper-roofed edge busbars in galvanneal steel (G.L.) sections.

DESCRIPTION: IAC-210

MANUFACTURER: C & S Electric Limited, Manufacturing Division, Plot No. 1A, Sector 42, Integrated Industrial Estate, Bangpur, Ghaziabad (U.P.) (Uttar Pradesh), INDIA

TESTED BY: Central Power Research Institute, Subgroup Testing & Development Station, Govindpura Road, Bhopal (M.P.) Madhya Pradesh, India

DATE OF TESTS: 17th, 20th and 20th December 2009

The apparatus is constructed in accordance with the description, drawings and photographs incorporated in this certificate that have been subjected to the series of primary tests in accordance with:

IS: 4045-2 (Part 1): 2005 for use IS: 4045-2:2005 incorporating Amendment 1: 2006, Clauses 8.2.1, 8.2.2, 8.2.3, 8.2.4 & 8.2.11

The results are shown in the reports of Primary Tests and the test reports attached hereto. The values obtained and the general performance are considered to comply with the above standards and to justify the ratings assigned by the manufacturer as stated below:

Percentage assigned by the manufacturer and proved by the tests see page 1.

The result of Primary Tests applies only to the apparatus tested. The responsibility for conformity of any apparatus having the same description, with the test results with the Manufacturer.

This Certificate comprises 03 pages: 0 drawings, 0 photographs, 0 photographs, 0 drawings and no other items. (See page 1)

Only design modifications of this certificate, or reproduction of this part incorporated by any person on which are other test results, are considered unless permission from Indian Testing and Certification Ltd., Indian House, Corporation Street, Madras - 600 004, England.

(Signature)
B.M. Mishra
ASTA Director

(Signature)
S.S. Singh

ASTA

Reference List - Domestic

CUSTOMER	PROJECT	PRODUCT	CITY
Kapoor Electricals Pvt. Ltd.	ASSAM Project	CBA500, LB C40	ASSAM
HEC Infra Projects Pvt Ltd. Ahmedabad	Brakes India Ltd. Jhagadia.	CBC2000, CBA 1000, CBA 500, SBA 100N2	AHMEDABAD
Palican Associates	Toyota Kirlosker	CBC400/630/800	BANGALORE
Micron Electricals	HP	CBC400	BANGALORE
Krishn Electricals	Nextteer Automotive	CBA250	BANGALORE
Micron Electricals	Alstom Transport India Ltd	CBA1250	BANGALORE
Micron Electricals	HP GR Tech Park	CBC315	BANGALORE
Krishn Electricals, Bangalore	Kriloskar Toyota	CBC630,800	BANGALORE
Pragathi Controls, Bangalore	Manipal Health Corporation, Bangalore	CBA630, CBA800, CBA1250, SBA200N2	BANGALORE
Sterling & Wilson Ltd, Patna	IIT, Patna	CBA250,400,500	BIHAR
Sterling & Wilson Ltd, Patna	IIT, Patna	CBA250,500,800	BIHAR
Spark On Rivulet, Pune	Virgo-Chennai	CBA630	CHENNAI
Sterling Wilson Pvt. Ltd	Perlos Expansion- Chennai	CBC630, CBC500, SBC125N2	CHENNAI
Micron Electrical	M/s Satyam, Chennai	CBA400, CBC630, CBC800, SBA175N2	CHENNAI
ETA Engg. Pvt Ltd	unipres India P Ltd Chennai	CBA800	CHENNAI
Sterling & Wilson	M/s., WABCO TVS ,Chennai	CBC400/2000	CHENNAI
Infosys Limited	Infosys-SDB9-Chennai	CBA250/400/630	CHENNAI
Cosmos Enterprises, Chennai	SAC Engineering Components Pvt Ltd, Gummidipondi	CBC630	CHENNAI
Sterling & Wilson, Chennai	Renault Nissan Line 2, Oragadam, T.N	CBC1000, SBA175N2, SBA200N1	CHENNAI
E Power Engineering, Chennai	Renault Nissan	CBA1000, SBA60N1,	CHENNAI
Kamladitya Construction Pvt. Ltd. Dwarka, New Delhi	NDMC Staff Quater, New Delhi	CBA 400	DELHI
Suprabhat Associates Pvt. Ltd., Delhi	Project at Khetri, Rajasthan	LBC404BASSP3, LBC402BASSP3	DELHI
Ahluwalia Contracts India limited Delhi	Hero moto Corp Neemrana Alwar	CBA400	DELHI
Consortium of Sudhir Power Projects Ltd. & Cobra Instalaciones y Servicios S.A Spain, New Delhi	DMRC CE-09 LOT-3, New Delhi	LBC258BG5SP3, LBC252BG5SP3	DELHI
Ramesh Electric Works, New Delhi	Sarita Vihar Under Pass, New Delhi	LBC634BGI5SP3, LBC404BGI5SP3	DELHI
Sudhir Power Projects Limited, Gurgaon	RCF, Raebareilly	CBA630	HARYANA
NKG INFRASTRUCTURE LIMITED, Faridabad	ESIC Hospital Faridabad	CBA1250, CBA1000, CBA800, CBA250	HARYANA
Triple A Engineering Pvt. Ltd., Gurgaon,	Vatika India Next, Gurgaon, Haryana	CBA630	HARYANA
Triple A Engineering Pvt. Ltd. Gurgaon,	Vatika Sovereign, Gurgaon	CBA630/300	HARYANA
Triple A Engineering Pvt. Ltd. Gurgaon,	Vatika Seven Lamps, Gurgaon	CBA800	HARYANA
Jayabheri Properties Pvt. Ltd.	Jayabheri Oven County, Hyderabad	CBA400 & CBA630	HYDERABAD
Sterling Electro Enterprise P Ltd	Mahindra Vehicles Mfg Ltd J Block	CBA630,500,400	HYDERABAD
Aster Electricals Engineering	Tempus Power,	CBA630/CBA400	HYDERABAD
Arjun Electricals	Rainbow Vistas	CBA630,400	HYDERABAD
Sterling & Wilson	lighton mobile (Perlos)	CBC400,500,630/ LBC25	HYDERABAD
Stelcit Power Systems	ESIC Hyderabad	CBA1000,800,630,200, SBA175N2,175N1	HYDERABAD
Aparna Constructions and Estate Pvt Ltd,	Aparna Hill Park	CBA630, CBA400	HYDERABAD
Cyber City Builders and developers Pvt Ltd	Cyber City Towers	CBA630, CBA800	HYDERABAD
Square A Enterprises, Hyderabad	NTPC, Pochampadu	CBA200, CBA250, SBA150N2, SBA125N1	HYDERABAD
Micron Electricals, Hyderabad	Devabhumi Relators Pvt Ltd, Hyderabad	LA16DA, SBA150N2, SBA175N2, SBA175N1	HYDERABAD
Aay Kay Electrical Enterprises, Hyderabad	My Home ABHRA, Hyderabad	CBA400,250	HYDERABAD
M/s The Power and control, Kolkata	IISER, Haringhata (Part-II)	CBA800, CBA315, CBA500	KOLKATA
Sterling & Wilson Ltd, Kolkata	Mani Casadona, Rajarhat	CBA1250,1000,800,630	KOLKATA
J.K Electric Engineering Works, Kolkata	IISER Haringhata, Kalyani	CBA400,250	KOLKATA
Sterling & Wilson Ltd, Kolkata	TCS Rajarhat, Kolkata	CU Flexibles	KOLKATA
Unity Infraprojects Limited	DCSEM-Anushakti Nagar	CBC 400	MUMBAI
Cimechel Engineers & Consultants,, Mumbai	DCSEM-Anushakti Nagar	CBC 400	MUMBAI
SWE Engineering Works Pvt Ltd L-333 Saritavihar	Amarpali Hotel noida	CBA1000,800,630,400,250	NOIDA
New Holland Fiat (India) Pvt Ltd, Noida	New Holland Fiat (India) Pvt Ltd, Noida	CBA1000, CBA200	NOIDA
Geetu Engineering Constructions pvt Ltd, Noida	Geetu Engineering Constructions pvt Ltd, Noida	CBA800	NOIDA
SUBROS LIMITED NOIDA	NOIDA	CBA315/SBA150N3/SBA100N2	NOIDA
Sterling & Wilson Limited, NOIDA, UP	New Holland Fiat India Pvt. Ltd., UP	CBA1000/250/CBC315	NOIDA

Reference List - Domestic

Orissa Industrial Infrastructure development Corporation, Bhubaneswar	IDCO Towers Bhubaneswar	CBC1250	ORISSA
Amber Electrotech Ltd ,New Delhi	AIIMS Bhubaneswar	CBA500	ORISSA
SPARK ON RIVULET	Pee Vee Textiles Ltd Pune	CBA250	PUNE
Mahindra Heavy Engineering Pune	Mahindra Heavy Engineering Pune	CBA630/400/315	PUNE
BCC Developers & Promoters Pvt. Ltd.Ludhiana	Rass Contractors & Engg., Ludhiana	CBA200	PUNJAB
Amtek Auto Ltd,	Amtek Piston Division Chopanki,Rajasthan	CBA1250,CBA1000,CBA800,CBA630	RAJASTHAN
Shree Electricals &Engineers	ICICI Jaipur	CBC400	RAJASTHAN
J.K. Electric Contractor, Rajasthan	New Rajasthan High Court	CBA800/400/200	RAJASTHAN
Triple A Engineering Pvt. Ltd. Jaipur, Rajasthan	Varika Infotech City, Jaipur-31	CBA630/800	RAJASTHAN
Happy electricals New delhi	AIIMS Rishikesh	CBA630,500 & SBA 175N2	RISHIKESH
Amber Electrotech Ltd ,New Delhi	AIIMS Rishikesh	CBA315,CBA400	RISHIKESH
Hitech Erectors Pvt ,New Delhi	New Rail Coach Factory Rae Barily,U.P	CBA630	UP
Sterling and Wilson Ltd	Rail Coach factory.Rae Bareilly	CBA630	UP
AFSA Traders	Nagpur	CBC400/630,CBA400	UP
Kamladitya Construction Pvt. Ltd-Bokaro	Ismu academic block-Dhanbad	CBA400,CBA800	UP



Reference List - Overseas

CUSTOMER	PROJECT	PRODUCT	COUNTRY
Doha Technical services	B+G+7 Al. Mahmoud	CBC40	Qatar
Orient Star international Doha Qatar	Stock order	CBC400,315	Qatar
Al. mufta Doha	Stock order	CBC630	Qatar
Tech Hard Building Material L.L.C Dubai UAE	Magore project	CBC 630	UAE
Tech Hard Building Material L.L.C Dubai UAE	Mindu Project	CBC 630	UAE
JSC SOEMI Russia	JSC SOEMI Russia	CBA400 & CBA630	Russia
Central Electricals International Ltd.	BIMA Towers	CBC630/315	UAE
Central Electricals International Ltd.	Fidha Tower kenya	CBA630/400	UAE
JSC SOEMI Russia	JSC SOEMI Russia	CBA400 & CBA630	Russia
Patronics Services (U) Ltd., Uganda	Self	CBC400	South Africa
ELTA Russia	self	CBC40N1	Russia
Specialised Power systems Ltd.	NA	CBA630	UAE
JSC SOEMI Russia	JSC SOEMI Russia	CBA250,400 & 630	Russia
Switchgear & Controls Ltd Kenya	Switchgear & Controls Ltd Kenya	CBC400	Kenya
Doha Technical Services	B+G+7	CBC400	Qatar
Orient Star	Stock order	CBC315/400	UAE
JSC SOEMI Russia	JSC SOEMI Russia	CB250,CBA400 & CBA630	Russia
Doha technical services	B+G+ 7 Residential Building	CBC400	Qatar
JSC SOEMI Russia	JSC SOEMI Russia	CB250,CBA400 & CBA630	Russia
Soemi Russia	Soemi Russia	CBA630/400	Russia
Specialised Power systems Ltd.	Specialised Power systems Ltd.	cbc315	UAE
SOEMI - Russia	SOEMI - Russia	CBA400,630,250	Russia
MEI Mumbai	Uganda	CBC400/315	South Africa
Soemi Russia	Self	CBA250,400.630	Russia
MEI Mumbai	Uganda	CBC630	South Africa
Central electrical	KSMS Kenya	CBC400	Kenya
Central electrical	MOE Busbar	CBC315/400/600	Kenya
JSC Automatikos Sisemos	Lithunia	CBA800	Russia
Central Electrical International Limited	NSSF Busbar	CBC400	Kenya
TD Soemi Ltd	Soemi Russia	CBA630	Russia
DOHA TECHNICAL SERVICES DOHA	B+G+& Al Mansoura	CBC315	Qatar
DOHA TECHNICAL SERVICES DOHA	Modification of Existing Project	CBC315	Qatar
Qatar Switchgear	Jaidah Tower	CBC315	Qatar
DOHA TECHNICAL SERVICES DOHA	Abllan Aquaf	63A	Qatar
Qatar Switchgear	Stock Order	CBA400/SBC40N1/CB-C50N1/CBC315	Qatar
Qatar Switchgear	qatar development bank	CBC400	Qatar
DTS doha	DTS Self Doha	EFU	Qatar
DTS doha	DTS Self Doha	EFU/PIB	Qatar
DTS Doha	B+G+6 Residential Building at Al Mansoura Doha	CBC315	Qatar
DTS Doha	DTS Stock Order	CBC315/CBC400	Qatar
Mohammed Hussain Al-Muftah Est Doha	Mohammed Hussain Al-Muftah Est Doha Stck Order	CBC400	UAE
Doha Technical Services, Doha- QATAR	Private Project Residential Building- Doha	CBC315	Qatar
Mohammed Hussain Al-Muftah Est Doha- QATAR	Doha Tower - Doha	CBC1250	Qatar
Doha Technical Services, Doha- QATAR	B+G+7 Residential building - Al Sadd - Doha	PIB	Qatar
Orient Star International -Doha	Stock Order- Doha, Qatar	CBC315 & 400A	Qatar
ROCHE Engineering Pvt .Ltd,Sri Lanka	Jinasena Engineering School,Sri Lanka	CBC315	Sri Lanka
Busbar Installations Pty. Ltd- Southdale	Craigcor Project - South Africa	CBA200A	South Africa
TD Soemi Ltd. - Russia	TD Soemi - Russia	CBA250A/400A	Russia
TD Soemi Ltd,Russia	TD Soemi, Russia	CBA630	Russia
Etacom NL	Amstredam	PIB	Australia
A.G.P Representaciones, Colombia	Colombia	CBA500,CBA315	Sri Lanka
Digi Drive Pvt Ltd,Faridabad	Tender,Tanzaniya-Thgough Digi Drive	CBC400	South Africa
Central Electricals International Ltd- KENYA	Kenya Polytechnic University & ICPAK	CBA315/SBA60N1	Kenya
MunHean Singapore PTE Ltd.SINGAPORE	Thanlynin star - additional PIB	PIB	Phillipines
MunHean Singapore PTE Ltd.SINGAPORE	E Block 3, Additional req	PIB	Phillipines
MunHean Singapore PTE Ltd.SINGAPORE	E Block 3, Additional PIB req.	PIB	Phillipines
MunHean Singapore PTE Ltd.SINGAPORE	Royal Sin Min - MYANMAR	CBA400A/SBA60N1	Myanmar
SL Switchgear Limited,NAIROBI, KENYA	NYERI HOSPITAL KENYA	CBC315	Kenya
MEI Industrial Corporation - Mumbai	Fourth Nigong Avenue & Holy Basillica Ph-2	CBC400	Kenya



Vatika India
Next, Gurgaon



HP Campus, Bangalore



New Holland Fiat Tractors (I) Pvt. Ltd.
Noida

Some Reference Installations



Dafna Tower 3&4, Doha



Westbay 44 Tower, Doha



Shek. Falak Twin Tower, Doha



Port Saeed, Dubai



Dubai Silicon Oasis



Ghusais, Dubai

isobar



Isolated Phase Busducts
(11~36kV up to 30000A)



Segregated / Non-Segregated
Phase Busducts
(415~33kV up to 6500A)

betobar



Low Voltage



Medium Voltage

metabar



Sandwich Busbar Trunking System
(Low- Impedance)
(400~6600A)



Air Insulated
Busbar Trunking System
(125~2000A)



Lighting Trunking System
(25~63A)



● C&S + Etacom Installations

*This Map is only for pictorial representation not to be scaled



GLOBAL SPECIALIST FOR POWER BUSBARS

India

Corporate Office:

222, Okhla Industrial Estate,
New Delhi - 110 020, India
Tel.: +91-11-30884912, 30887520-29
Fax: +91-11-2684 8241, 2684 7342

Regional Office:

Northern Region / Export

222, Okhla Industrial Estate,
New Delhi - 110 020, India
Tel.: +91-11-30887520-29
Fax: +91-11-26848241, 26847342
email : info.metabar@cselectric.co.in

Southern Region

#N607, North Block, Rear Wing,
Manipal Center, 47, Dickenson Road,
Bengaluru -560 042, Karnataka, India
Tel.: +91-80-30570359, 340
Fax: +91-80- 25584839
email: info.metabar@cselectric.co.in

Eastern Region

#24, Park Street, Development House,
4th Floor, Kolkata -700016
West Bengal, India
Tel.: +91-033-40011417
Fax: +91-033-22275849/40011417
email: info.metabar@cselectric.co.in

Western Region

A-301/302, 3rd Floor, Nav Bharat Estate
Zakaria Bunder Rd., Sewri (W)
Mumbai - 400015, Maharashtra, India
Tel: +91-22-24114727 - 28
Fax: +91-22-241137858, 24114704
email: info.metabar@cselectric.co.in

Works:

Noida

B1, Site-IV, Surajpur Industrial Area,
Kasna Road, Greater Noida,
Distt. Gautam Budh Nagar, (U.P.), India

Haridwar

Plot No. 1C, Sector 8C,
Integrated Industrial Estate
(SIDCUL), Ranipur, Haridwar
Uttarakhand - 249403, India

Haridwar

Plot No. 1A, Sector 8C,
Integrated Industrial Estate
(SIDCUL), Ranipur, Haridwar
Uttarakhand - 249403, India

Europe

Eta-com BNV

Scheldeweg 4,
2850, Boom,
Belgium
Tel.: +32-3-880.64.00
Fax: +32-3-844.42.50
email: busduct@etacom.be

Eta-com BV

Zwarte Zee 2-6,
3144, DE MAASSLUIS,
The Netherlands
Tel.: +31-1059-16422
Fax: +31-1059-20673
email: info@etacom.nl

Eta-com UK Preedcrete Ltd.

Unit 19 /20, Horsham Court,
City Business Centre, 6, Brighton Road,
HORSHAM, West Sussex, RH13 5BB,
United Kingdom
Tel.: +44-1-403265767
Fax: +44-1-403254131
email: busduct@eta-com.co.uk

Middle East

Middle East (FZE) Office:

PO Box 124999
Saif Zone Office, X2-13
Sharjah - UAE
Tel.: +971 65579786
Fax: +971 65579786
E-mail: aje.desai@eta-com.co.uk

www.cselectric.co.in
www.etacomcs.com



www.facebook.com/CSElectricLimited



We touch your electricity everyday!