

High-Tech Range

MRR1 - Multifunctional Generator Rotor Protection Relay



Contents

1. Introduction and application

2. Features and Characteristics

3. Design

3.1 Connections

3.1.1 Output Relays

3.1.2 Blocking input

3.1.3 External reset input

3.2 Display

3.3 LEDs

4. Working principle

4.1 Rotor earth fault protection

4.2 Excitation current supervision

5. Operation and settings

5.1 Setting- and measuring values

5.2 Setting procedure

5.2.1 Threshold value and switching delay

5.2.2 Setting of slave address

5.2.3 Reset

5.3 Blocking of protective functions and assignment of the output relays

5.3.1 Blocking of protective functions

5.3.2 Assignment of the output relays

6. Testing and commissioning

6.1 Power-On

6.2 Testing the output relays

6.3 Checking the set values

6.4 Secondary injection test

6.4.1 Test equipment

6.4.2 Example of test circuit

6.4.3 Checking the insulation measuring circuit

6.4.4 Checking the excitation current circuit

6.4.5 Checking the pickup and reset value of the relay

6.4.6 Checking the tripping relay

6.5 Primary injection test

6.6 Maintenance

7. Technical data

7.1 Measuring input circuits

7.2 Common data

7.3 Setting ranges and steps

7.4 Dimensional drawing

8. Order form

1. Introduction and application

The generator rotor protection relay *MRR1* combines rotor earth fault protection, excitation over- and undercurrent protection as well as rotating diode failure protection.

Thus providing a powerful protection regarding the rotor of synchronous generators, covering the following ANSI codes:

- 37 DC undercurrent relay
- 40 Field relay
- 58 Rectification failure relay
- 64 Ground detector relay
- 76 DC overcurrent relay

The rotor earth fault element detects high- and low resistance earth faults of the rotor winding. It is equipped with two stages, one for alarm, one for trip.

The excitation current protection element supervises the DC excitation current of brushless excitor machines. The protective functions are: Undercurrent, overcurrent and ripple detection for diode failure protection.

2. Features and characteristics

Besides features described in the general MRdescription, *MRR1* provides:

- Detection of high impedance earth faults with a low frequency (1 Hz) test voltage
- Short circuit and overvoltage proof measuring input for the earth fault protection
- Exciter current measurement galvanically isolated via Hall-transducer, measuring range 0 to 20 A
- Display of insulation resistance
- Display of the excitation current
- Excitation current over- and undercurrent protection with independent settings for current and delay time
- Detection of diode failures by supervision of the ripple component of the excitation current
- Two stage supervision of the rotor insulation resistance with independent settings for resistance and time delay
- Digital inputs for blocking and for remote reset
- Programmable function of the blocking input
- Programmable assignment of protective functions to output relays
- Remote interfacing via RS485 (optional)

3. Design

3.1 Connections

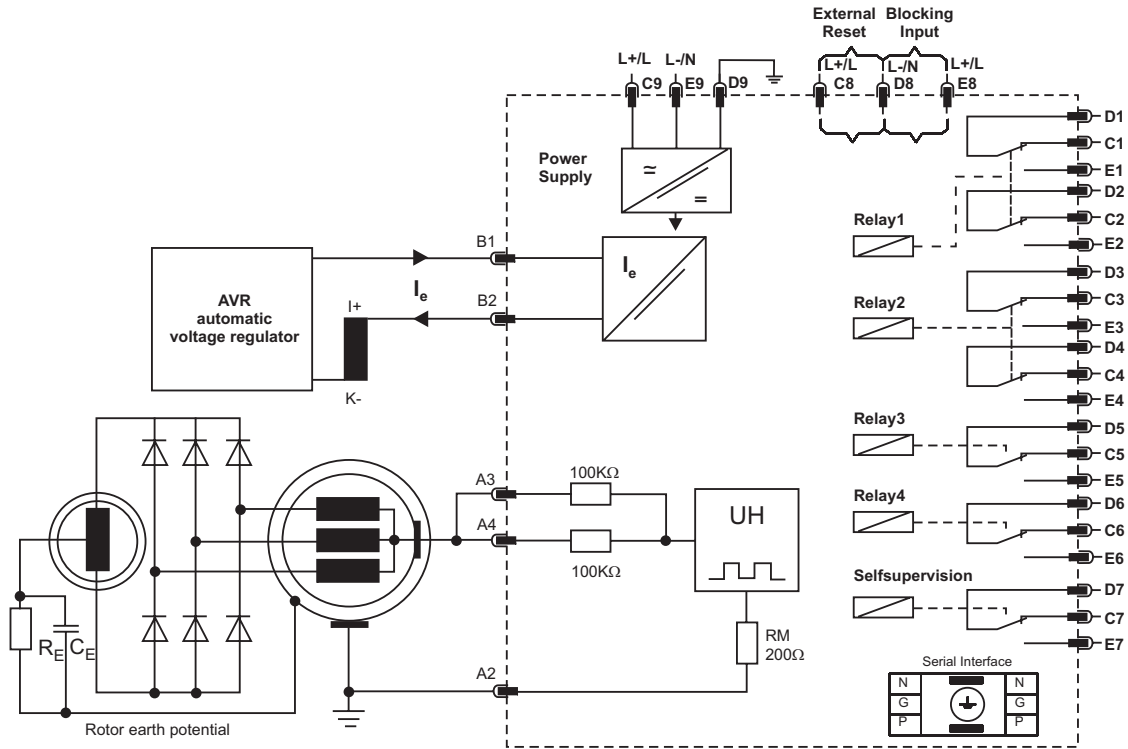

Fig. 3.1 : Connection diagram

3.1.1 Output relays

The MRR1 has 5 output relays. Relays 1 and 2 are provided with two change-over contacts each, the other relays with one change-over.

Function of relays 1 - 4 is programmable. Status of self-supervision is indicated by relay 5. The relays are allocated to the following contacts :

- Output relay 1: C1, D1, E1 and C2, D2, E2
- Output relay 2: C3, D3, E3 and C4, D4, E4
- Output relay 3: C5, D5, E5
- Output relay 4: C6, D6, E6
- Output relay 5: Self-supervision (internal fault of the relay) C7, D7, E7

All relays are normally off, only the self-supervision relay is normally on.

3.1.2 Blocking input

When required to inhibit the selected functions to be blocked, the auxiliary voltage has to be switched to D8/E8 (please also refer to chapter 5.3.1)

3.1.3 External reset input

See chapter 5.2.2

3.2 Display

	Function	Display in	LED / colour
Measuring values	Measuring value of the insulation resistance	kOhm	R green
	Measuring value of the excitation current	A	I_e green
	Ripple component of the excitation current	%	I_r green
Setting values	Insulation resistance alarm element	kOhm	R_w green
	Tripping time for insulation resistance alarm element	s	t_{RW} red
	Insulation resistance trip element	kOhm	$R<$ green
	Tripping time for insulation resistance trip element	s	$t_{R<}$ red
	Setting for excitation undercurrent element	A	$I_{e<}$ green
	Delay time setting for excitation undercurrent element	s	$t_{I_{e<}}$ red
	Setting for excitation overcurrent element	A	$I_{e>}$ green
	Delay time setting for excitation overcurrent element	s	$t_{I_{e>}}$ red
	Setting for ripple component of the excitation current	%	I_r green
	Delay time setting for the ripple component element	s	t_{I_r} red
	Slave address for the RS485 interface		RS yellow

Table 3.1: Possibilities for indication by the display

Functions can be called via push button ENTER.

For changing to the next value use push button <SELECT/RESET>.

3.3 LEDs

All LEDs (except LED RS) are two-coloured. The LEDs on the left side, next to the alphanumeric display light up green during measuring and red after tripping.

The LEDs below the push button <SELECT/RESET> are lit green during setting and inquiry procedure of the setting values which are printed on the left side next to the LEDs. The LEDs will light up red after activation of the setting values next to their right side.

The LED marked with letters RS lights up during setting of the slave address of the device for serial data communication (RS485).

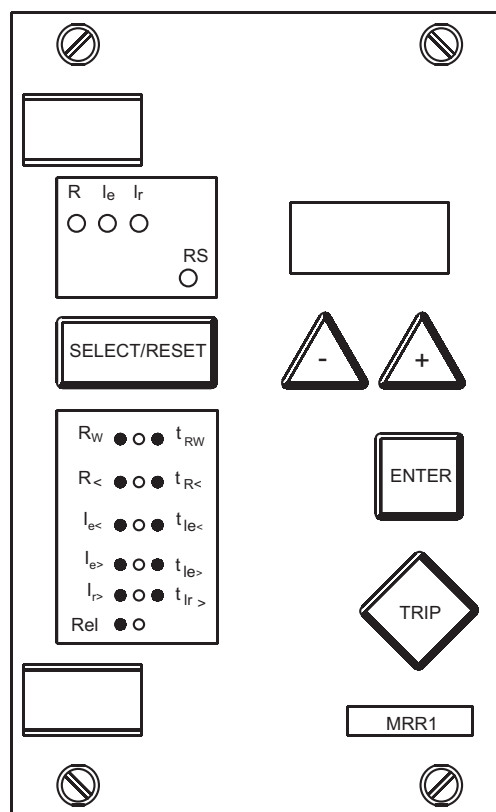

Fig. 3.2 : Front plate

4. Working principle

4.1 Rotor earth fault protection

A single earth fault on the field windings of a synchronous generator produces no immediate damaging effect. It must be detected and removed because of the possibility of a second earth fault that could short a part of the field winding and cause severe damage. *MRR1* provides an alarm and a trip element for the rotor earth fault protection.

The insulation resistance measurement system of the *MRR1* can be used for synchronous generators of both types, with and without brushes.

It works with a low frequency alternating test voltage (1 Hz, +/- 24V) which is connected via slip rings to the main exciter winding and to rotor earth (ref. to connection diagram).

The low frequency of the test voltage is used to avoid malfunction due to the field-to-earth capacitance (C_E) which can reach values up to 1 μ F on large generators. The test voltage is fed via two current limiting resistors (R_V) to both ends of the field winding. If only one end of the field winding can be connected, the terminals A3 and A4 should be paralleled.

The earth current is measured via shunt resistor R_M .

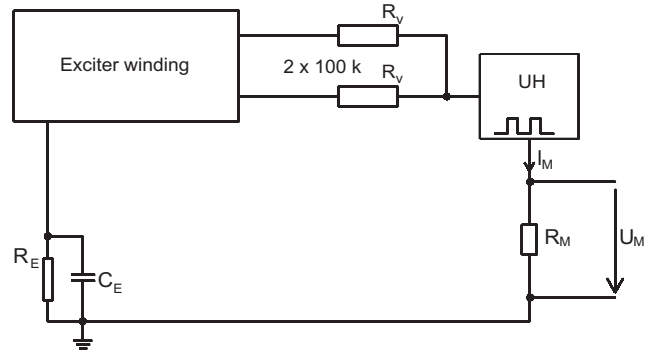

Fig. 4.1: Measuring principle of the earth current

The insulation resistance measurement is based on the subsequent measurement of the shunt resistor voltage of two consecutive half cycles, i.e. positive and negative test voltage.

From the differential voltage between the positive and negative measuring voltage at the end of each half cycle the insulation resistance is calculated. Thus avoiding wrong measurement due to the earth capacitance and possible voltage offsets.

Figure 4.2 explains the measuring principle

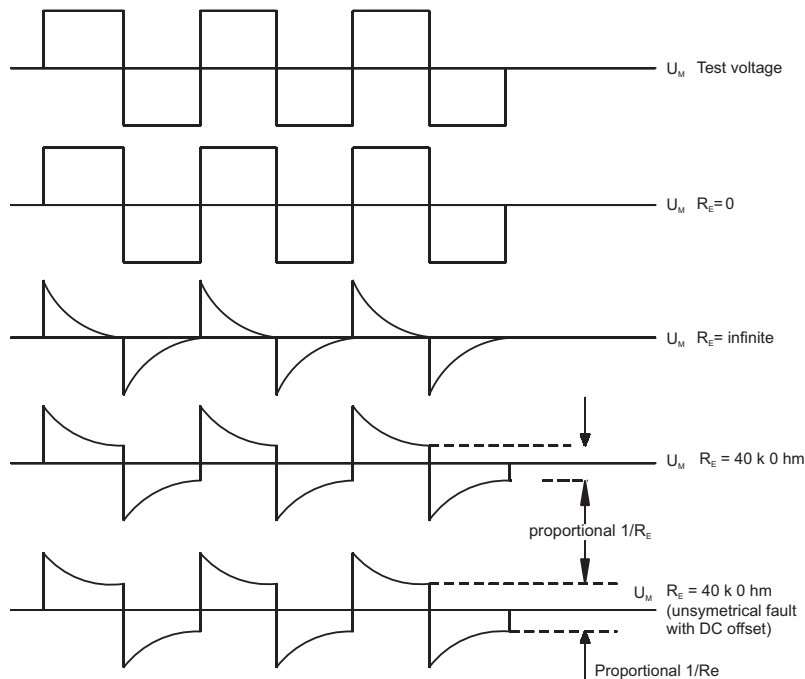

Figure 4.2 Measuring principle

4.2 Excitation current supervision

Failures in the excitation system of a synchronous generator may cause severe damage to the rotor of the generator as well as undesirable operating conditions :

Failure	Effect
AVR failure; undercurrent in parallel operation	Excessive reactive current flow to the generator ⇒ System stability endangered
AVR failure; undercurrent in single operation	System undervoltage if ⇒ System stability endangered
AVR failure; overcurrent in parallel operation	Excessive reactive current flow to the system ⇒ Thermal overload of the exciter winding
AVR failure; overcurrent in single operation	System overvoltage if in single operation ⇒ Thermal overload of the exciter winding
AVR failure; overcurrent Rotating diode open	Rotor damage due to overheating Increased excitation current ⇒ overheating of the rotor system
Rotating diode short	Excessive excitation current ⇒ severe overheating of the rotor system

Table 4.1: Effects of different failures

Excitation current supervision:

The excitation current supervision comprises of three elements: under- and overcurrent and ripple component measurement. These elements cover above mentioned failures of the generator excitation system.

Undercurrent protection:

The undercurrent protection is a definite time element. The current setting ($I_{e<}$) should be chosen at about 70% of the no load excitation current of the generator. The time delay $t_{ie<}$ should be set to a value well above the AVR response time (e.g. 2 s), to allow transient deexcitation of the generator due to voltage regulator action.

If required the MRR1 may be blocked by connecting supply voltage to terminals D8/E8. This might be necessary during start up of the generator.

Overcurrent protection:

The overcurrent protection is a definite time element. The current setting ($I_{e>}$) should be chosen at about 120% of the nominal excitation current of the generator. The time delay $t_{ie>}$ should be set to a value well above the AVR response time and required short circuit times (e.g. 3 s), to allow transient overexcitation of the generator due to voltage regulator action.

Diode failure protection

The diode failure protection is based on the measurement of the ripple component of the excitation current related to the mean value of the excitation current as per following formula :

$$I_r (\%) = \frac{|I_{e,max} - I_{e,min}|}{I_{e=}} \cdot 100$$

Typical values for I_r :

- All diodes all right: $I_r \approx 15...20\%$
- One diode open: $I_r \approx 110\%$
- One diode short: $I_r \approx 200\%$

The setting of $I_{r>}$ should be chosen at about 40% to 50%. The tripping time t_{ir} should be instantaneous or with only a small delay, e.g. 200 ms. In case of a diode short the rotor system is extremely endangered!

Hint!

The required setting depend on various factors like :

- Required power factor of the generator
- Required minimum short circuit duration etc.

5. Operation and settings

5.1 Setting and measuring values

By pressing push button <SELECT/RESET> always the next value in sequence is displayed. At first measuring values are shown followed by the setting values. If the relay is in trip condition, display of setting values can only be achieved after pressing push button <ENTER>. Display of measuring and setting values is ended and the relay resets when push button <SELECT/RESET> is pressed for a certain time. In the display "CSE" appears again.

Measuring value	LED
R Insulation resistance	green
I _e Exciter current	green
I _r Ripple component of the exciter current	green

Table 5.1: Measuring values

Setting values		LED
R _w	Pickup value of insulation resistance supervision (warning)	green
t _{RW}	Tripping delay for R _w	red
R<	Pickup value of insulation resistance supervision (trip)	green
t _{R<}	Tripping delay for R<	red
I _{e<}	Pickup value exciter undercurrent element	green
t _{Ie<}	Tripping delay for I<	red
I _{e>}	Pickup value exciter overcurrent element	green
t _{Ie>}	Tripping delay for I>	red
I _r	Pickup value for ripple voltage supervision	green
t _{I_r}	Tripping delay for I _r	red
RS	Slave address of the serial interface	yellow

Table 5.2 Setting values

5.2 Setting procedure

Before changing a parameter a password has to be entered first.

The gradual changing procedure is clearly explained in the following table:

Display	Procedure	Relevant push button
Actual value	Value change	<+> or <->
Changed value	Initiate storing	yes:<ENTER> no: <SELECT>
SAV?	Checkback: really storing?	yes:<ENTER> no: <SELECT>
PSW?	Enter password, a combination of 4 push buttons	<ENTER> , <+>, <-> or <SELECT/RESET>
SAV!	When password correct: storing of new parameter	Hold <ENTER> for 2 s

Table 5.3 Changing of parameters and storing

5.2.1 Pickup value and tripping delay

For each element the pickup value and tripping delay can be adjusted. When the set pickup value is either exceeded or falls below, the corresponding LED flashes. After elaps of the tripping delay trip of the relay is initiated. Should the duration of pickup be shorter than the set tripping delay, this is signalled by periodical flashing of the corresponding LED.

Complete blocking of an element :

An element is blocked when the parameter is set to EXIT by pressing repeatedly push button <-> or <+>.

Warning only:

Should only excitation of an element be intended and not tripping, the respective trip delay can be set to EXIT by push button <+> (pressed repeatedly) and then pickup only is indicated by the LEDs.

5.2.2 Setting of slave address

When pressing push buttons <+> and <-> the slave address can be set in the range from 1 - 32, hereby LED RS lights up.

5.2.3 Reset

MRR1 has the following 3 possibilities to reset the display as well as the output relays.

(see description "MR-Digital Multifunctional Relays".)

Manual reset

- by pressing push button <SELECT/RESET> for some time (abt. 3 secs.)

Electrical reset

- by applying aux. voltage to C8/D8

Software reset

- software reset has the same effect as the <SELECT/RESET> push button.

Resetting the display is only possible when there is no pickup anymore (otherwise signal "TRIP" will still remain in the display and the relays remain activated). Resetting the relay does not change the preset parameters.

5.3 Blocking of protective functions and assignment of the output relays

By pressing the <ENTER> and <TRIP> push buttons simultaneously the menu for blocking of protective functions and assignment of the output relays is activated. The assignments can either be done by using the push buttons on the front plate or via serial interface RS485. The assignment mode can be terminated at any time by pressing <SELECT/RESET> push button for some time (3s).

5.3.1 Blocking of protective functions

After activating the menu for blocking of protective functions the following functions can be blocked selectively:

- Earth fault protection (warning)
- Earth fault protection (trip)
- Excitation undercurrent
- Excitation overcurrent
- Rotating diode failure protection

By repeatedly pressing the <SELECT/RESET> push button, the functions to be blocked are selected one after another. The corresponding LED lights up simultaneously. The display shows "BLOC" or "NO_B". BLOC means this function is blocked, if auxiliary voltage is applied to the external blocking input. NO_B means applying aux. voltage to the external blocking input has no influence on this protection function. Blocking or not blocking a function can be selected with the push buttons <+> or <-> and be stored with <ENTER> after input of the password. Storage of the new setting to be done as shown in table 5.3.

Display	Blocking function	Selection with push button
BLOC	yes	<+>
NO_B	no	<->

Table 5.4: Effect of the blocking input

With the default setting all functions shown in above table are blocked via input D8/E8.

After all function have been displayed and push button <SELECT/RESET> has been pressed, the relay switches over to the assignment mode of the output relays.

5.3.2 Assignment of the output relays

Unit MRR1 has five output relays. The fifth output relay is provided as normally on alarm relay for self supervision. Output relays 1 - 4 are normally off and can be assigned as alarm or tripping relays to the different supervision functions which can either be done by using the push buttons on the front plate or via serial interface RS485. The assignment of the output relays is similar to the setting of parameters, however, only in the assignment mode. By pressing push buttons <ENTER> and <TRIP> simultaneously, the assignment mode is selected.

The assignment of the relays will be done as follows:

LEDs R_w , $R_<$, $I_{e<}$, $I_{e>}$ are two-coloured and light up green when the output relays are assigned as alarm relays and red as tripping relays.

Definition:

Alarm relays are activated at pickup of the relay. Tripping relays are only activated after elapse of the tripping delay.

After the assignment mode has been activated, first LED Rel and R light up green. Now one or several of the four output relays can be assigned to the insulation resistance supervision as alarm relays. At the same time the selected alarm relays for the insulation resistance supervision are indicated on the display. Indication "1 _ _ _" means that output relay 1 is assigned to this element. When the display shows " _ _ _ _", no alarm relay is assigned to this element. The assignment of output relays 1 - 4 can be changed by pressing <+> and <-> push buttons. The selected assignment can be stored by pressing push button <ENTER> and subsequent input of the password. By pressing push button <SELECT/RESET>, LED R lights up red. The output relays can now be assigned to this element as tripping relays.

Relays 1 - 4 are selected in the same way as described before. By repeated pressing of the <SELECT/RESET> push button and assignment of the relays all supervision elements can be assigned separately to the output relays. The assignment mode can be terminated at any time by pressing the <SELECT/RESET> push button for some time (abt. 3 s).

LED	Colour	Display	Function	Assigned relay			
				1	2	3	4
R_w	green red	_ _ _ _2_ _	Warning Tripping		x		
$R_<$	green red	_ _ _ 1_ _ _	Warning Tripping	x			
$I_{e<}$	green red	_ _ _ _ _ 3_	Warning Tripping			x	
$I_{e>}$	green red	_ _ _ _ _ 3_	Warning Tripping			x	
I_r	green red	_ _ _ _ _ _4	Warning Tripping				x

Table 5.5: Default assignment of the output relays

Note:

- The function of jumper J2 described in general description "MR Digital Multifunctional Relays" has no function. For relays without assignment mode this jumper is used for parameter setting of alarm relays (activation at pickup or tripping).

6. Relay testing and commissioning

The following test instructions should help to verify the protection relay performance before or during commissioning of the protection system. To avoid a relay damage and to ensure a correct relay operation, be sure that:

- the auxiliary power supply rating corresponds to the auxiliary voltage on site.
- the rated values of the relay correspond to the plant data on site
- all signal circuits and output relay circuits are connected correctly.

6.1 Power-On

Prior to switch on the auxiliary power supply, be sure that the auxiliary supply voltage corresponds to the rated data on the type plate.

Switch on the auxiliary power supply to the relay and check that the message "CSE" appears on the display and the self supervision alarm relay (watchdog) is energized (Contact terminals D7 and E7 closed).

6.2 Testing the output relays

Prior to commencing this test, interrupt the tripping circuit to the circuit breaker if tripping is not desired.

By pressing the push button <TRIP> once, the display shows the first part of the software version of the relay (e.g. "D08-"). By pressing the push button <TRIP> twice, the display shows the second part of the software version of the relay (e.g. "4.01"). The software version should be quoted in all correspondence. Pressing the <TRIP> button once more, the display shows "PSW?". Please enter the correct password to proceed with the test. The message "TRI?" will follow. Confirm this message by pressing the push button <TRIP> again. All output relays should then be activated and the self supervision alarm relay (watchdog) be deenergized one after another. Thereafter, reset all output relays back to their normal positions by pressing the push button <SELECT/RESET>.

6.3 Checking the set values

By repeatedly pressing the push button <SELECT/RESET>, all relay set values may be checked. Set value modification can be done with the push button <+><-> and <ENTER> (refer to chapter 5).

6.4 Secondary injection test

6.4.1 Test equipment

- Voltmeter and ammeter
- Auxiliary power supply with the voltage corresponding to the rated data on the type plate
- Single-phase voltage supply unit
- Timer to measure the operating time
- Switching device
- Test leads and tools
- Adjustable resistance

6.4.2 Example of a test circuit

Fig. 6.1 shows a simple example of a test circuit with variable current source for testing the relay.

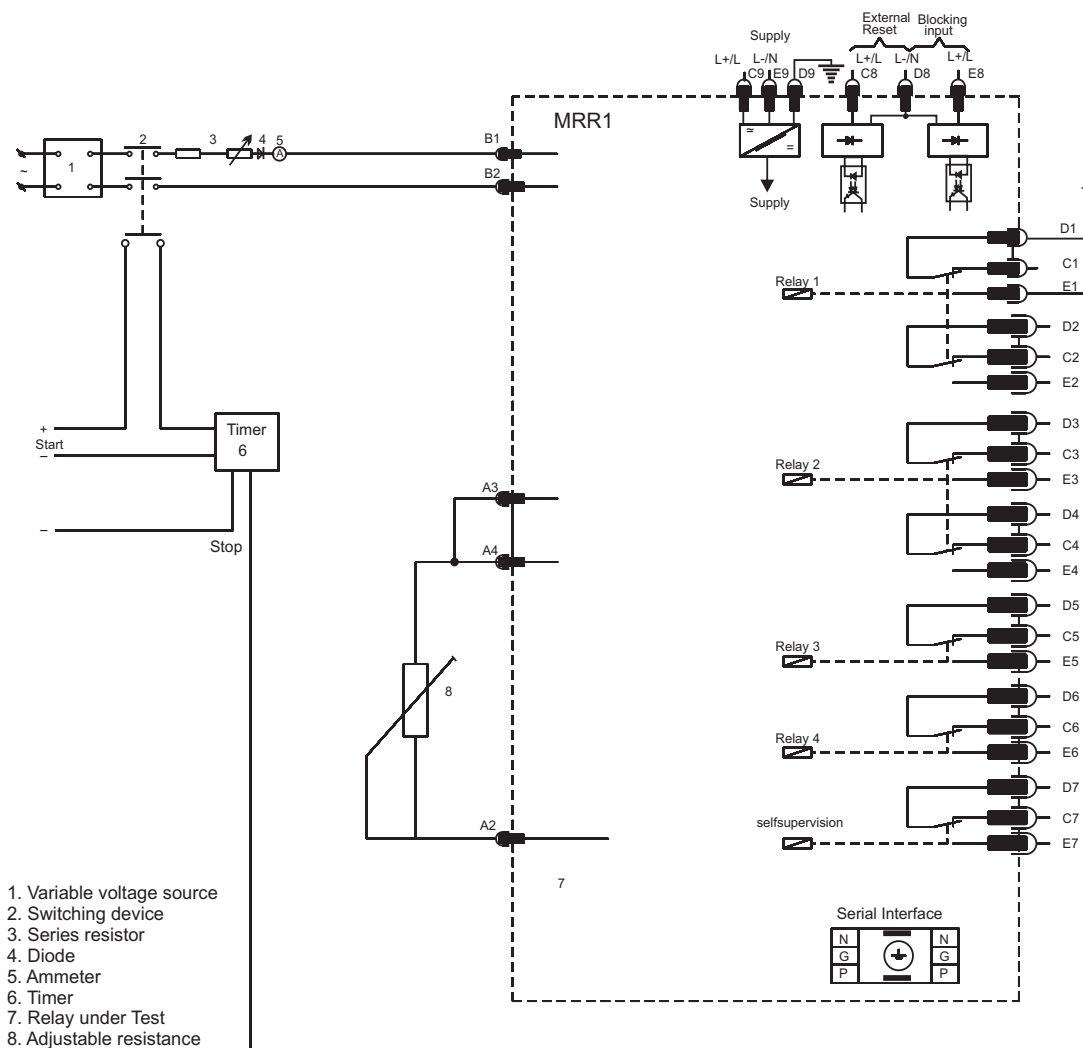

Fig. 6.1: Test circuit

6.4.3 Checking the insulation measuring circuit

For checking the insulation measuring circuit a resistor with a defined value is simply connected to terminals A2-A3/A4 (A3 and A4 are to be bridged). By pressing push button <SELECT/RESET>, measuring value R is displayed. This value must be identical with the defined value.

6.4.4 Checking the excitation current circuit

For checking the measuring values a current must be injected (terminals B1 - B2) which is below the set pickup current of the MRR1. After renewed pressing the <SELECT/RESET> push button, measuring value I_e is displayed and can be checked by using an ammeter.

Example : For this test circuit the dc current is generated from a single-pulse rectification. If a current of $I_{AV} = 5A$ is fed to the MRR1, this value has to be indicated at the display. By repeatedly pressing the <SELECT/RESET> push button, measuring value I_r is displayed.

Due to the conversion factor for single-pulse rectification of 0.318, the peak value at an average of $I_{AV} = 5A$ comes to 15.73A. The ripple is calculated by using the following formula :

$$I_r\% = \frac{I_{e,max} - I_{e,min}}{I_e} \times 100\%$$

The measuring value I_r resulting from this is 314 %.

Note : For testing the ripple current by single pulse (half wave) rectification the injected excitation current should be more than 2A.

6.4.5 Checking the pickup value and reset value

For testing these values a current smaller than the adjusted pickup value has to be injected (terminals B1 - B2). The current is now to be increased until the relay picks up, which is indicated by lighting up of LEDs I_e and $I_e >$. At the same time the output relay selected by the parameter setting mode (see chapter 5.3.2) trips. The resetting value is ascertained by slowly decreasing the test current until the output relay releases.

6.4.6 Checking the tripping delay

For checking the tripping delay a timer is to be connected to the trip output relay contact. The timer should be started simultaneously with the test current injection in the current input circuit and stopped at the instant the relay trips. The test current should be 1.5 times the operating current. The

tripping delay measured by the timer should not vary more than 3 % or less than 150ms from the adjusted tripping delay.

For checking the insulation measuring circuit the same method can be used. The permissible tolerance for this is 3 % or less than 1s from the adjusted tripping delay.

6.5 Real injection test

Generally, a test with real exciter current could be carried out in the similar manner as the injection test with current sources above described. Since the cost and potential hazards are very high for such a test, especially if staged fault tests are intended, these tests are usually limited to very important protective relays in the power system.

Because of its powerful combined indicating and measuring functions, you have still the possibilities to test the MRR1 relay in the manner of a primary injection without extra expenditures and time consumption. In actual service, for example, the measured current values may be compared with the ammeter on the switch-board panel to verify that the relay works and measures correctly.

6.6 Maintenance

Maintenance testing is generally done on site at regular intervals. These intervals vary among users depending on many factors: e.g. the type of protective relays employed; the importance of the primary equipment being protected; the user's past experience with the relay, etc.

For electromechanical or static relays, maintenance testing will be performed at least once a year according to the experiences. For digital relays like MRR1, this interval can be substantially longer. This is because:

- The MR-relays are equipped with very wide self supervision functions, so that many faults in the relay can be detected and signalled during service. Important: The self-supervision output relay must be connected to a central alarm panel!
- The combined measuring functions of MR-relays enable supervision the relay functions during service.
- The combined TRIP test function of the MR-relay allows to test the relay output circuits.

A testing interval of two years for maintenance will, therefore, be recommended.

During a maintenance test, the relay functions including the operating values and relay tripping times should be tested.

7. Technical data

7.1 Measuring input circuits

Insulation resistance measuring:

Measuring aux. voltage U_H	:	± 24 V
Measuring frequency	:	$f_H = 0.5$ Hz
Measuring resistance range	:	1 k Ω to 1 M Ω
Max. input voltage	:	600 V DC
Exciter DC current measuring	:	
Nominal current I_N	:	10 A DC
Power consumption in current circuit	:	<1 VA

7.2 Common data

Dropout to pickup ratio	:	$\geq 98\%$
Returning time	:	≤ 30 ms
Minimum operating time	:	≤ 100 ms
Weight	:	ca. 1.5 kg
Influences:		
Temperature influence at -20°C up to 70°C	:	$\pm 2.5\%$

7.3 Setting ranges and steps

Function	Parameter	Setting ranges	Steps	Tolerance
Pickup value of insulation resistance supervision (warning)	R_W	20 k Ω ...200 k Ω / (EXIT)	20...50: 1,0 50...100: 2,0	$\leq \pm 5\%$ of setting value
Tripping delay for R_W	t_{RW}	1...50 sec / (EXIT)	0.1; 0.2; 0.5; 1.0	$\pm 3\%$ or ± 1.0 s
Pickup value of insulation resistance supervision (trip)	$R_{<}$	2 k Ω ...20 k Ω / (EXIT)	0.2; 0.5; 1.0	$\leq \pm 5\%$ of setting value
Tripping delay for $R_{<}$	$t_{R<}$	1...50 sec / (EXIT)	0.1; 0.2; 0.5; 1.0	$\pm 3\%$ or ± 1.0 s
Pickup value of exciter undercurrent element	$I_{e<}$	(EXIT) / 0,2...20 A	0.05; 0.1; 0.2; 0.5	$\pm 5\%$ of setting value or ± 0.20 A
Tripping delay for $I_{e<}$	$t_{Ie<}$	0.1...10 sec / (EXIT)	0.05; 0.1; 0.2	$\pm 3\%$ or ± 150 ms
Pickup value of exciter overcurrent element	$I_{e>}$	0.2...20 A / (EXIT)	0.05	$\pm 5\%$ of setting value or ± 0.20 A
Tripping delay for $I_{e>}$	$t_{Ie>}$	0.1...10 sec / (EXIT)	0.05; 0.1; 0.2	$\pm 3\%$ or ± 150 ms
Pickup value of "ripple component"	I_r	10...400 % (EXIT)	2	$\pm 5\%$ of setting value
Tripping delay for IR	t_{I_r}	0.1...10 sec / (EXIT)	0.05; 0.1; 0.2	$\pm 3\%$ or ± 150 ms
Slave address RS485	RS	1...32	1	-

Table 7.1: Setting ranges and steps

7.4 Dimensional drawing

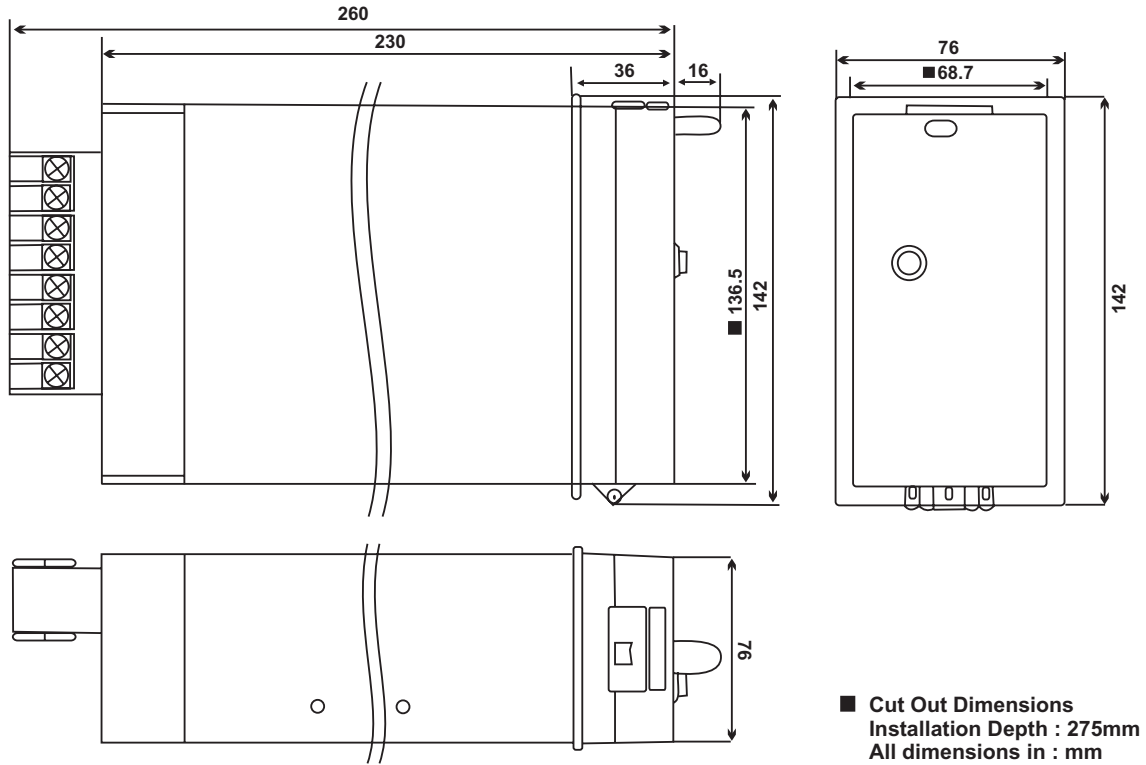

Please note:

A distance of 50 mm is necessary when the units are mounted one below the other in order to allow easy opening of the front cover of the housing. The front cover opens downwards.

8. Order form

Rotor earth relay	MRR1-		
Auxiliary Voltage 24V (16 to 60 VAC/16 to 80 VDC) 110 V (50 to 270 VAC/70 to 360 VDC)	L H		
Serial interface		R	
Housing (12TE) 19"-rack Flush mounting			A D

Technical data subject to change without notice!

Setting-list MRR1

Project: _____

CSE job.-no.: _____

Function group: = _____ Location: + _____

Relay code: _____

Relay functions: _____

Password: _____

Function	Unit	Default settings	Actual settings
R_w	Pickup value of insulation resistance supervision (warning)	k Ω	80.0
t_{Rw}	Tripping delay for R_w	s	1.00
$R<$	Pickup value of insulation resistance supervision (trip)	k Ω	20.0
$t_{R<}$	Tripping delay for $R<$	s	1.00
$I_{e<}$	Pickup value exciter undercurrent element	A	0.50
$t_{Ie<}$	Tripping delay for $I<$	s	0.10
$I_{e>}$	Pickup value exciter overcurrent element	A	5.00
$t_{Ie>}$	Tripping delay for $I>$	s	0.1
I_r	Pickup value for ripple voltage supervision	%	50
t_{I_r}	Tripping delay for I_r	s	0.1
RS	Slave address of the serial interface		1

Blocked function and relay assignment :

Code jumper :

Function	Blocking via D8/E8	Relay assignment			
		1	2	3	4
R_w	①	Pickup			
		Tripping		①	
$R<$	①	Pickup			
		Tripping	①		
$I_{e<}$	①	Pickup			
		Tripping			①
$I_{e>}$	①	pickup			
		Tripping			①
I_r	①	Pickup			
		Tripping			①

	J1	J2	J3
On		①	
Off	①	②	①

Default settings are marked with ①.

② The Code jumper J2 has no function.

Please mark your settings if they are different from default settings.



C&S Electric Limited

(Protection & Control Division)

44, Okhla Industrial Estate, New Delhi -110 020 (INDIA)

Phone : +91 11- 66602414, 30883745/54/64 Fax: +91 11- 66602413

E-mail: cspc@cselectric.co.in Web : www.cselectric.co.in

Marketing Offices :

AHMEDABAD: +91 79 30074534/35/36 FAX : +91 79 30074519 **BANGALORE:** +91 80 25586147, 25594939 FAX : +91 25584839
BHUBANESWAR : +91 674 2507265 FAX : +91 674 2507265 **CHANDIGARH :** +91 172 272613, 3062624 FAX : +91 172 2726153
CHENNAI : +91 44 39180531/32/33/34 FAX:+91 44 39180514 **DELHI :** +91 11 30838822-25 Fax:+91 11 30838826 **HYDERABAD :** +91 40 27813003
FAX : +91 40 27812987 **KOLKATA :** +91 33 22275850/51 FAX : +91 33 22275849 **MUMBAI :** +91 22 24114727/28 FAX : +91 22 24126631
NAGPUR : +91 712 5616651 FAX : +91 712 5616651 **PUNE :** +91 20 30283244/45 FAX : +91 20 30283245 **RAIPUR :** +91 771 320852433/34