

IRU-Pro

AC Voltage Relay 27, 59, 59N, 47, 59D

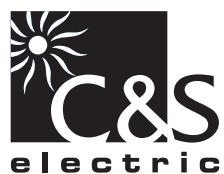
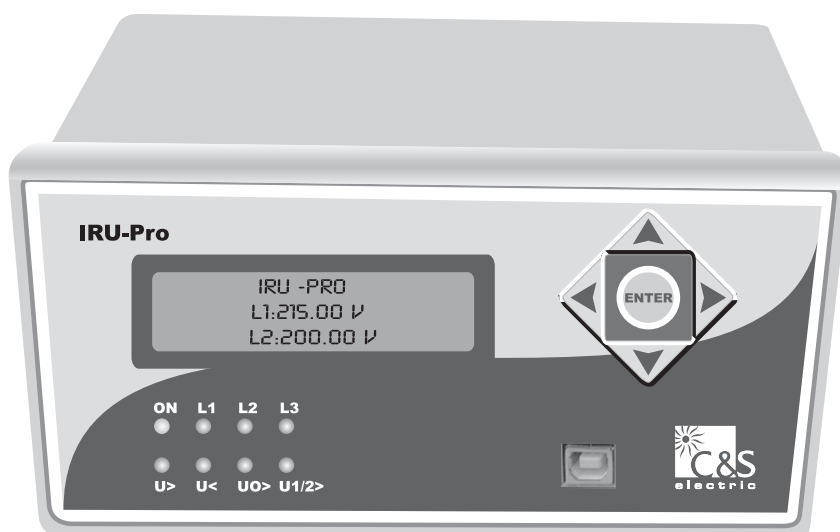

C&S Electric Limited
(Protection & Control Division)

Contents

- 1. Introduction**
- 2. Features & Characteristics**
- 3. Model for Voltage Protection**
- 4. Voltage Protection**
 - 4.1 Under / Overvoltage
 - 4.2 Zero-sequence overvoltage
 - 4.3 Negative sequence over voltage
 - 4.4 Positive sequence over voltage
 - 4.5 Output Trip contact
 - 4.6 Front Plate
- 5. Setting groups**
- 6. Measurements**
- 7. Event record**
- 8. Fault record**
- 9. Communication**
- 10. User interface**
- 11. Hardware & case**
- 12. Relay testing and commissioning**
 - 12.1 Testing the output relays
 - 12.2 Test of symmetrical components
 - 12.3 Wrong phase sequence
 - 12.4 Phase failure
 - 12.5. Earth fault
- 13. Terminal Description**
- 14. Setting Procedure**
- 15. Technical data**
- 16. VT ratios**
- 17. Accuracy**
- 18. Setting Range**
- 19. Connection diagrams**
- 20. Cases & Dimensions**
- 21. Ordering Information**

1. Introduction

PRO range of relays provide reliable and high performance protection.

The IRU_PRO is a relay for AC voltage supervision with universal application; it protects the three-phase network against over-, under- voltage, unbalance or earth faults in isolated networks. Beside the pure RMS value measurement of the line voltage the IRU_PRO evaluates the symmetrical components (U1, U2 & U0 sequence system). By evaluating these components relay IRU_PRO can detect the phase sequence, voltage unbalance and earth-faults

2. Features & Characteristics

- Numeric DSP technology based relay.
- Digital filtering of the measured values by using discrete Fourier analysis to suppress higher harmonics and D.C. components induced by faults or system operations.
- Two Groups of configuration parameter.
- Protection ANSI: 27, 59, 59N, 47, 59D
- Voltage supervision each with two step under-/ and over voltage detection.
- Inverse as well as Definite Trip timing curve selection for under/over voltage.
- Separate tripping elements for over- and under-voltage and positive sequence system.
- Over voltage detection in positive, negative- and zero sequence system.
- Display of measuring values of the line voltages and system voltages U0, U1 and U2 as RMS values.
- Suitable for Star /Delta connection.
- VT Ratio for Primary Voltage display configuration.
- Block on under voltage in case of Power failure (user selectable).
- Last 10 faults saving in memory for all line voltages and the voltages of the symmetrical components, with time stamp.
- Recording of up to last 100 Events with time stamp.
- Assignment matrix for output relays for all protections.
- Suitable for 50Hz/ 60Hz.
- Single Phase/ Three Phase selection.
- USB front end interface for PC/Laptop interface.
- Front-end Live Link simulation support for testing of relay even without three phase injection voltage source.
- Off line Trip Test mode.
- Wide range SMPS based Auxiliary Supply (24-260VAC/24-360VDC).
- Front IP54 transparent dust cover.

PROTECTION FUNCTIONS OVERVIEW	
ANSI	Phase-to-neutral or phase-to-phase voltage Protection (Delta/star configuration)
27	Phase under voltage
59	Phase over voltage
59N	Zero-sequence over voltage
47	Negative sequence over voltage
59D	Positive sequence Over voltage
	Over /Under Voltage Blocking
	Single/ Three Phase Selection
	Three output relays
	Front Communication (USB)

3. Model for Voltage Protection

IRU_PRO relays are available in the following configurations:

Model	PTs	Zero sequence calculation	Negative sequence calculation	Positive sequence calculation
IRU-PRO-O	3	Numerical	X	X
IRU-PRO-U	3	Numerical	X	X
IRU-PRO-UO	3	Numerical	X	X
IRU-PRO-UOR	4	External PT	✓	✓

- * U_N will be $1/\sqrt{3}$ times of 110V / 400V in star configuration
- * 230V model is available only in star configuration

4. Voltage protection

The relay is equipped with an independent, 2-step over- ($U>$, $U>>$) and under voltage supervision ($U<$, $U<<$) simultaneously with separately adjustable tripping values and delay times. Voltage measuring is 3-phase. In this process there is a continuous comparison of the line conductor voltages in case of a delta connection and of the phase voltages in case of a star connection with the preset limit values.

The highest voltage is always evaluated for over voltage supervision and the lowest voltage for under voltage supervision.

A distinction is made between 1-phase and 3-phase tripping.

With 1-phase tripping the voltages are evaluated as follows:

$U</math>/ $U<<$: Activation cum tripping takes place if at least one phase has fallen short of the tripping value.$

$U>/U>>$: Activation cum tripping takes place if at least one phase has exceeded the tripping value.

With 3-phase tripping the voltages are evaluated as follows:

$U</math>/ $U<<$: Activation cum tripping takes place if all three phases have fallen short of the tripping value. But if pickup occurs in only one or two phase then phase LED of those phases will glow.$

$U>/U>>$: Activation cum tripping takes place if all three phases have exceeded the tripping value. But if pickup occurs in only one or two phase then phase LED of those phases will glow.

4.1 Under / over voltage

Two thresholds are available for each function: each one can be independently activated or deactivated. If a threshold is activated, it can be configured to detect:

Under Voltage Protection will not get activated unless 1-phase or 3-Phase (depending upon the phase setting in MMI) crosses the level of the selected scheme : SCH-A / SCH-B/ SCH-C

SCH-A : Undervoltage protection is activated without crossing any threshold level.

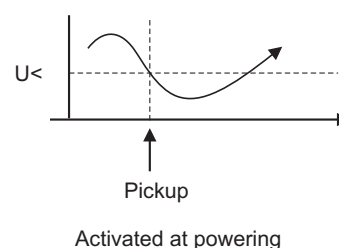

SCH-B : Under voltage protection is activated only after voltage goes above the set value of undervoltage pickup.

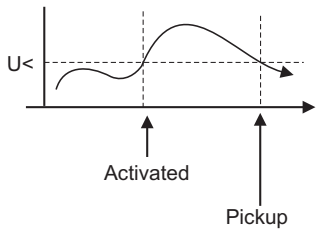

SCH -C: Under voltage Protection is activated only after the voltage crosses the set UV theshold level.

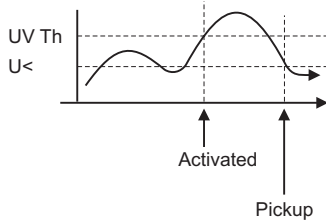

NOTE :

The IRU_PRO relays provide a **block on under voltage** (parameter **UlossBlk**) in case of power failure (voltage lesser than 10% Vn), if Power failure Protection is enabled.

4.2 Zero-sequence over voltage

IRU_PRO relays will operate from the zero sequence voltage, which is calculated internally, or from the residual voltage, which is measured directly or internally

$$U_0 = 1/3 | (U_1 + U_2 + U_3) |$$

4.3 Negative sequence over voltage

This function is based on the negative-sequence component of the voltage, which is calculated internally and displayed on the screen of the front panel: It is designed to detect any voltage unbalance condition.

$$U_2 = 1/3 | (U_1 + a^2U_2 + aU_3) |$$

4.4 Positive sequence over voltage

This function is based on the positive phase sequence component of the voltage, which is calculated internally.

$$U_1 = 1/3 | (U_1 + aU_2 + a^2U_3) |$$

4.5 Output Trip Contact

The IRU_PRO is provided with three tripping relay. All three relays can be configure to any fault through relay assignment menu of MMI.

Relay reset operation can be configurable in automatic reset or manual reset mode from MMI (man machine interface). In automatic reset mode relay will be reset after the voltage goes below/above the pick-up level for OV & UV. In manual mode relay will be reset by pressing reset button for 1 second if fault has been over.

4.6 Front Plate

At the front of the relay following operating and indicating elements are arranged:

- Five push switches for set values of normal tripping characteristics including a RESET push switch.
- Eight LEDs for indicating faults and readiness to operate.
- LCD display to display settings and running values etc.
- Running parameter's are fundamental voltages for L1,L2,L3 phases, zero sequence voltage U₀ , Positive phase sequence voltage U₁ ,Negative phase sequence voltage U₂.

The 'RESET' switch is provided for acknowledgement and reset of the fault LED's/Relay.

The eight lamps on the front plate of IRU_PRO have following functions:

- Lamp 'ON' indicates that the relay is in service.
- Lamps L1 , L2 , L3 indicates pickup phase.
- Lamp U> flash state indicates pickup due to over voltage & steady state indicates trip due to over voltage.
- Lamp U< flash state indicates pickup due to under voltage & steady state indicates trip due to Under voltage.
- Lamp U₀> flash state indicates pickup due to zero sequence & steady state indicates trip due to neutral Displacement.
- Lamp U_{1/2}> flash state indicates pickup due to Positive/Negative sequence component & steady state indicates trip.

5. Setting groups

The IRU_PRO relays have two independent setting groups, which can be used to adapt the protection functions to different operating conditions. The switch from one setting group to another will only take effect if no protection is running, to prevent unwanted tripping.

6. Measurements

Depending on the configuration of the VTs connected to IRU_PRO relays, the following values will be measured and displayed as true RMS values on the back-lit screen:

In addition, the IRU_PRO relays calculate the following values internally:

- phase-to-neutral voltages L1 , L2, L3
- phase-to-phase voltages L12, L23, L31
- Zero sequence voltage U₀
- Positive sequence voltage U₁
- Negative sequence voltage U₂

7. Event record

Any change of state of logic inputs, output contacts or protection functions will be recorded in the non-volatile memory of the IRU_PRO relays, with a maximum of 100 events. When the memory is full, the oldest events will be deleted, Each event can be retrieved locally to a PC using the IRU_PRO support software through front USB port or can be viewed on LCD.

8. Fault record

The IRU_PRO relays can store the last 10 faults that have occurred in non-volatile memory. Fault1 is the latest fault. Each record provides the following information:

- Date and time of fault
- Origin of fault (under voltage, etc.)
- Faulted phase(s)
- Magnitude of phase-to-neutral or phase-to-phase voltages
- Magnitude of the zero-sequence voltage (if available)
- Magnitude of the positive sequence voltage (if available)
- Magnitude of the Negative sequence voltage (if available)

9. Communication

One communication port is available on IRU_PRO relay based on ordering information. This front USB port provides a local communication with PC. The front end software provided for relay is fully Windows TM compatible.

The front end software of IRU_PRO relays has following functions:

- To edit the parameters of relay
- To view the running parameters of relay.
- To download the last 10 faults of relay
- To download the last 100 Events of relay
- To Test the complete functionality of all protections of relay without using any three phase injection voltage source

10. User interface

The user interface for IRU_PRO relays comprises:

- LCD display of 2 x 16 characters
- Eight dedicated LEDs to provide information such as "Trip", "Alarm", Over, Under Voltage protection information.

Star-Connection:

- Phase-to-neutral voltages: LED L1, L2, L3

Delta-connection:

- Phase-to-phase voltages: LED L1+L2, L2+L3, L3+L1
Green ON LED flashing indication gives the status of healthiness of protection relay.

- Five tactile keys for editing/scrolling through the menus with password protection.

11. Hardware & case

All the models of the IRU_PRO range have a plastic IP54 protected case, and can be flush-mounted in switchboard or panel. External connections are made via Barrier terminal blocks. Each terminal connection is suitable for 8mm ring type lugs with M3.5 screw fixing.

12. Relay testing and commissioning

12.1 Testing the output relays

Select the <TRIP TEST> menu from MMI, It will start operating the LEDs & Contacts one by one, unless the enter key is pressed again.

12.2 Test of symmetrical components

For this test the relay has to be correctly connected with all of the three phases and the star point.

If the measuring voltage system is symmetrical, the unit should indicate the following measuring values:

Measuring Value	Indication
L1,L2,L3	U_N
U1	$\approx U_N$
U2	≈ 0
U0	≈ 0

12.3 Wrong phase sequence

For this test two phases must be reversed. The third phase and the star point N are connected as usual. The theoretical indicating values are:

Measuring Value	Indication
L1,L2,L3	U_N
U1	≈ 0
U2	$\approx U_N$
U0	≈ 0

12.4 Phase failure

The IRU_PRO is now to be connected with the two phases L2 and L3 and with the neutral conductor. The two phases must be assigned correctly. The measuring input of phase L1 is connected with the star point of the relay in order to prevent interference voltages at the input. (This simulation is realistic because in a real case of failure other relays in parallel or the voltage transformer itself would cause this "pull down" effect).

The test can basically be carried out with any phase. The result of the measurement differs only in the indicating values for the phase voltages L1-L3.

Measuring Value	Indication
L1	0
L2, L3	U_N
U1	$\approx 2/3 \times U_N$
U2	$\approx 1/3 \times U_N$
U0	$\approx 1/3 \times U_N$

12.5 Earth fault

For this test all conductors L1-L3 have to be correctly connected. The star point N from the mains is not connected. Instead the star point of the IRU_PRO is connected with phase L1. This type of connection simulates an earth fault of phase L1.

Measuring Value	Indication
L1	0
L2,L3	$\sqrt{3} \times U_N$
U1	$\approx U_N$
U2	≈ 0
U0	$\approx U_N$

13. Terminal Description

There are two terminal blocks A & B. Block A is for Voltage connection while Block B is for Auxiliary & trip contact connection as per below table.

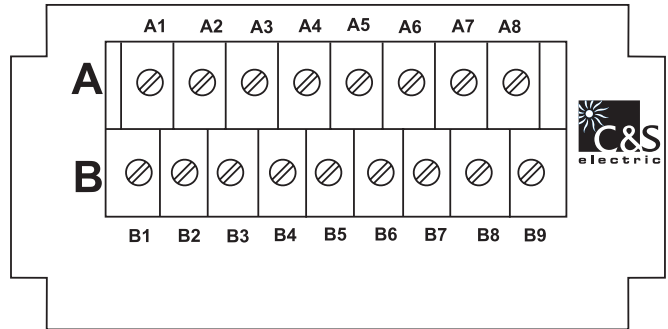

Terminal	Description
A	
A1	L1 Voltage Transformer Phase
A2	L1 Voltage Transformer Neutral
A3	L2 Voltage Transformer Phase
A4	L2 Voltage Transformer Neutral
A5	L3 Voltage Transformer Phase
A6	L3 Voltage Transformer Neutral
A7	Residual Transformer Phase
A8	Residual Transformer Neutral
B	
B1	Relay-3 NO
B2	Relay-3 COMM
B3	Relay-2 NO
B4	Relay-2 COMM
B5	Relay-1 NO
B6	Relay-1 COMM
B7	Auxiliary Supply Line (Non polar)
B8	Auxiliary Supply Line (Non polar)
B9	Earth

14. Setting Procedure

MENU	DISPLAY	DISCRIPTION
Menu 1 Default Page (Running Parameters)	L1 :XXX.XX V L2 :XXX.XX V L3 :XXX.XX V U0 :XXX.XX V U1 :XXX.XX V U2 :XXX.XX V	Fundamental voltage of L1 phase Fundamental voltage of L2phase Fundamental voltage of L3phase Zero sequence voltage Positive sequence voltage Negative sequence voltage
Menu 2 (Pressing Reset Key)	# EDIT / VIEW MENU# <PROTECTION> <RELAY CONFIG.> <TRIP TEST> <FAULT RECORD> <EVENT RECORD> ←BACK	Group -1, Group-2 Protection parameter's Relay Configuration Setting Trip Testing Fault Record Event Record
Menu 3 (Pressing Reset Key on PROTECTION)	# GROUP SELECTN # <GROUP-1> <GROUP-2> <ACTIVE-GROUP> ←BACK	Group1 Setting Group2 Setting Change Active Group Back to previous page
Menu 4 (Pressing Reset Key on GROUP-1 OR GROUP-2 Selection)	# PROTECTION # <Under Voltage> <Over Voltage> <Zero Seq. OV> <Pos./Neg. OV> <Set-up Config.> ← BACK	Undervoltage parameter setting Overvoltage parameter setting Zero sequence OV parameter setting Positive / Negative sequence parameter setting Relay set-up configuration setting
Menu 5 (Pressing Reset Key on UnderVoltage Selection)	# UnderVoltage # UVchar:DEFT/IDMT UlossBlk:Disable UV-SCH:SCH-A/SCH-B/SCH-C UV-THRE:XXX %Un U<Prot: Disable/Enable U<Pkup:XXX %U _N U<Ti:X.XX U<Td:XX.XXs U<<Prot:Disable/Enable U<<Pkup:XXX%U _N U<<Td:XX.XXs ← BACK	Undervoltage Characteristic selection Blocking on loss of voltage enable/disable Undervoltage Protection Scheme selection Undervoltage Threshold selection(for SCH-C) Undervoltage Protection Blocking/unblocking Undervoltage Pickup setting Undervoltage TMS Setting Undervoltage Definite time setting Undervoltage Protection 2 nd level Block/unblock Undervoltage Pickup setting for 2 nd level Undervoltage Definite time setting for 2 nd level

Setting Procedure

MENU	DISPLAY	DISCRIPTION
Menu 6 (Pressing Reset Key on OverVoltage Selection)	# OverVoltage# OVchar: DEFT/IDMT U>Prot: Disable/Enable U>Pkup:XXX %U _N U>Ti:X.XX U>Td:XX.XXs U>>Prot:Disable/Enable U>>Pkup:XXX%U _N U>>Td:XX.XXs ← BACK	Overvoltage Characteristic selection Overvoltage Protection Blocking/unblocking Overvoltage Pickup setting Overvoltage TMS Setting Overvoltage Definite time setting Overvoltage Protection 2 nd level Block/unblock Overvoltage Pickup setting for 2 nd level Overvoltage Definite time setting for 2 nd level
Menu 7 (Pressing Reset Key on Zero Seq. OV Selection)	# Zero Seq. OV# U0char: DEFT U0>Prot: Disable/Enable U0>Pkup:XXX %U _N U0>Td:XX.XXs ← BACK	Zero sequenceOV Characteristic Zero sequenceOV Protection Blocking/unblocking Zero sequenceOV Pickup setting Zero sequenceOV Definite time setting
Menu 8 (Pressing Reset Key on Pos./Neg. OV Selection)	# Pos./Neg. OV # U1>Prot: Disable/Enable U1>Pkup:XXX%U _N U1>Td:XX.XXs U2>Prot: Disable/Enable U2>Pkup:XXX%U _N U2>Td:XX.XXs ← BACK	Positive sequence unbalance Protection Blocking/unblocking Positive sequence OV Pickup setting Positive sequence OV Definite time setting Negative sequence unbalance Protection Blocking/unblocking Negative sequence OV Pickup setting Negative sequence OV Definite time setting
Menu 9 (Pressing Reset Key on Set-up Config. Selection)	#Set-up Config. # Nom. Freq. Fn: XX Hz Protectn : 1- PHASE / 3-PHASE VT RATIO : XXXX Wire Config. : STAR / DELTA	50Hz/60Hz Frequency selection Single / Three phase selection VT Ratio Selection for primary voltage display Star / Delta wiring selection
Menu 10 (Pressing Reset Key on ACTIVE-GROUP Selection)	# GROUP # Active Group G1/ G2 ← BACK	Change the active group
Menu 11 (Pressing Reset Key on RELAY CONFIG. Selection)	#RELAY CONFIG.# <PASSWORD CHNG> <RELAY ASSIGN> <RELAY RESET> <COMM-ADDRESS> <SET TIME/DATE> <LOAD DEFAULT> <FACTORY SETNG> ←BACK	Change password Relay Assignment Relay Reset Slave Address Clock Setting Set default setting of relay Factory setting

Setting Procedure

MENU	DISPLAY	DISCRIPTION
Menu 12 (Pressing Reset Key on PASSWORD CHNGE selection)	#PASSWORD CHNG# Enter Password XXXX New Password XXXX Re-Password XXXX ! SUCCESS ! Password Changed	
Menu 13 (Pressing Reset Key on RELAY ASSIGN Selection)	# RLYAssignment # U< - - - U<< - - - U> - - - U>> - - - U1> - - - U2> - - - U0> - - - ←BACK	Relay assignment for Undervoltage Relay assignment for Undervoltage Level2 Relay assignment for Overvoltage Relay assignment for Overvoltage Level2 Relay assignment for Positive Sequence OV Relay assignment for Negative Sequence OV Relay assignment for Zero Sequence OV
Menu 14 (Pressing Reset Key on RELAY RESET selection)	# RELAY-RESET# AUTO / MANUAL ← BACK	Relay reset Auto / Manual mode selection
Menu 15 (Pressing Reset Key on SLAVE- ADDRESS selection)	# SLAVE ADDRESS # SlaveAddress: xx ← BACK	Slave address selection for front communication
Menu 16 (Pressing Reset Key on SET TIME & DATE selection)	# CLOCK # Hour:XXX Min:XXX Sec:XXX Day:XXX Mnt:XXX Year:XXX ← BACK	To set Hour of clock To set Minute of clock To set Second of clock To set Date of clock To set Month of clock To set Year of clock
Menu 17 (Pressing Reset Key on LOAD DEFAULT selection)	Enter Password XXXX	Set default setting of relay
Menu 18 (Pressing Reset Key on FACTORY SETNG selection)	Enter Password XXXXXX	(Not for user configuration)
Menu 19 (Pressing Reset Key on TRIP TEST selection)	Enter Password XXXX Offline TRIP Test Press Reset KEY	To test Relay and LED Functioning

Setting Procedure

MENU	DISPLAY	DISCRIPTION
Menu 20 (Pressing Reset Key on FAULT RECORD Selection)	#FAULT-MENU# <FAULT-SELECTN> <FAULT-VIEW> <FAULT ERASE> ←BACK	Fault number selection To view Fault data To Erase all 10 Faults
Menu 21 (Pressing Reset Key on FAULT-SELECTN)	# FAULT-NUMBER # FaultNo: XX ← BACK	Fault number selection to view fault details. 1st fault no is latest fault no.
Menu 22 (Pressing Reset Key on FAULT-VIEW Selection)	# FAULT-VIEW # <F-TYPE>:——— [F]L1 XXX.XX V [F]L2 XXX.XX V [F]L3 XXX.XX V [F]U0 XXX.XX V [F]U1 XXX.XX V [F]U2 XXX.XX V Hour Min XX:XX Sec Msec XX:XXX <DATE>XX:XX:XX ←BACK	Type of Fault occurred L1 phase voltage at the time of Fault L2 phase voltage at the time of Fault L3 phase voltage at the time of Fault U0 voltage at the time of Fault U1 voltage at the time of Fault U2 voltage at the time of Fault Hour & Minute of Fault Second & millisecond of Fault Date of Fault
Menu 23 (Pressing Reset Key on FAULT ERASE Selection	# FAULT-ERASE # ? Erase—WARNING ? YES NO CANCEL ←BACK	To Erase all 10 Faults
Menu 24 (Pressing Reset Key on EVENT RECORD Selection)	# EVENT-MENU # <EVENT-SELECTN> <EVENT-VIEW> <EVENT ERASE> ←BACK	Event number selection To view Event with it's Time stamp To Erase all 100 Event's
Menu 25 (Pressing Reset Key on EVENT-SELECTION Selection)	# EVENT-NUMBER # EventNo: XX ←BACK	Event number selection to view
Menu 26 (Pressing Reset Key on EVENT VIEW Selection)	# EVENT VIEW # <E>: ——— Hour Min XXX:X Sec Msec XXX:XX Date XXX:XXX:XX ←BACK	Type of Event Hour & Minute of Event Second & millisecond of Event Date of Event
Menu 27 (Pressing Reset Key on EVENT ERASE Selection)	#EVENT-ERASE# ?Erase—WARNING ? YES NO CANCEL ←BACK	To Erase all 100 Events

15. Technical data

Mechanical specifications

Design	: Weight approx. 1Kg
Mounting	: Rack or flush mounting.
Enclosure Protection	: Front Panel: IP 54
Dimensions	: See dimensions diagram
PC Interface	: USB type B connector

Environmental conditions

(Recommended Ambient temperature range)

Operating Temperature Range:
Continuous Withstand -25 to +55°C

Limit(Note 1) -25 to +70°C. Storage Temperature Range:
-25 to +70°C

Note: The upper limit is permissible not for for continuous period.

Solar Radiation:

Avoid exposure of the front panel to direct solar adiation.

Mechanical environment

Vibration Test	IEC 60255-21-1, class 2.
Shock and Bump Test	IEC 60255-21-2, class 1.
Seismic Test	IEC 60255-21-3, Class 2.

Product safety

Type tests

S.N.	Description of test	Standard
1	Insulation testl	EC 60255-5
2	Dielectric test	IEC 60255-5
3	5 KV impulse voltage test	IEC 60255-5
4	High freq interference test severity class 3	IEC 60255-22-1
5	Radio interference suppression test	EN55011 cl 5.1.2
6	Radio interference suppression test	EN55011 cl 5.22.2
7	Radiated radio freq electromagnetic field immunity test	IEC 60255-22-3
8	Conductive RF immunity test	ENV50141
9	Surge immunity	EN61000-4-5
10	ESD test severity class 3	EN61000-4-2
11	Fast transient disturbance test	IEC 60255-22-4
12	Power frequency magnetic Field immunity test	IEC61000-4-8

Ratings

Auxiliary voltage

SMPS Based
24V... 260 VAC / 24V—360VDC (Tolarance 5%)

Output Relay Contacts

The output contacts of the IRU_PRO relays are AgCdO dry contacts.

Make and carry	30A for 3s
Carry	8A continuous
Break	DC : 50W resistive
	DC : 25W inductive (L/R = 40ms)

AC : 1250VA
AC : 1250 VA inductive (cos Θ = 0.5)
5A and 300V
10 000 operation minimum
100 000 operation minimum
< 10 ms

Burdens

Voltage circuits

NOMINAL VOLTAGE (UN)

Un = 110V	: <0.25 VA
Un = 230V	: <0.36 VA
Un = 400V	: <0.42 VA

Duration

Thermal withstand continuous (2x Un)

16. VT ratios

The primary can be independently set for each set of VT inputs, for example the residual VT ratio can be different to that used for the phase voltages. Range is as per below

Primary VT Ratio	Step
1- 1000	1

17. Accuracy

MEASUREMENTS ACCURACY at nominal frequency

Quantity	Range	Accuracy
Phase Voltage	0.3xUn to 1.5xUn &<0.3x Un	< $\pm 2\%$ $\pm 0.4\%$ Un
Phase Sequence component	0.3xUn to 1.5xUn &<0.3xUn	< $\pm 5\%$ $\pm 1\%$ Un

TRIP TIME ACCURACY FOR UNDER/OVER VOLTAGE

Operate time accuracy at definite –time characteristic: $\pm 3\%$ of the set start value or ± 40 ms.
Operate time accuracy at IDMT characteristic: ± 40 ms or the accuracy appearing when the measured voltage varies $\pm 2\%$.

18. Setting Range : (IRU -PRO-UOR-XX)

S.No.	Feature's	Setting Name	Setting Range	Step's
1	Phase selection	SINGLE/THREE		
2	VT Ratio	VT Ratio	1-1000	1
4	Wiring Connection	STAR/ DELTA		
5	Protection			
6	Undervoltage U< & U<<	Characteristic	IDMT/DEFT	
		Blocking on loss of volt	Enable/Disable	
		Undervoltage Protection Scheme	SCH-A/SCH-B/SCH-C	-
		Undervoltage threshold	50-100% of Un	5% x Un
		U< Protection Blocking	Enable/Disable	-
		U< Pickup setting	5 - 120% of Un	1% x Un
		U< TMS Setting	0.05 2.00	0.01
		U<Definite time setting	30ms - 20s	0.01s
		U<< Protection Blocking	Enable/Disable	-
		U<< Pickup setting	5 - 120% of Un	1% x Un
		U<<Definite time setting	0.03 - 20 sec	0.01s
7	Overvoltage U> & U>>	Characteristic	IDMT/DEFT	
		U> Protection Blocking	Enable/Disable	-
		U> Pickup setting	20 - 150% of Un	1% x Un
		U> TMS Setting	0.05 2.00	0.01
		U>Definite time setting	30ms - 20s	0.01s
		U>> Protection Blocking	Enable/Disable	-
		U>>Pickup setting	20 - 150% of Un	1% x Un
		U>>Definite time setting	0.03 - 20 sec	0.01s
8	Zero sequence Over Voltage U0>	Characteristic	DEFT	
		U0> Protection Blocking	Enable/Disable	-
		U0> Pickup setting	2 - 50% of Un* (* IRU-PRO-UOR) 2 - 100% of Un** (** IRU-PRO-U/O/UO)	1% x Un
		U0> Definite time setting	0.03 - 20s	0.01s
9	Positive/Negative sequence Voltage U1 > U2 >	U1 > Protection Blocking	Enable/Disable	-
		U1> Pickup setting	10 - 100% of Un	1% x Un
		U1> Definite time setting	0.03 - 10s	0.01s
		U2 > Protection Blocking	Enable/Disable	
		U2> Pickup setting	10 - 100% of Un	1% x Un
	U2> Definite time setting	0.03 - 10s	0.01s	
10	Relay assignment	RELAY 1 ,2,3		
11	Relay Reset Auto/Manual	Auto/Manual		
12	Slave address	1 - 32		

Inverse Time Delay Characteristic

The inverse characteristic is defined by the following formula

$$t = \left(\frac{TMS}{\frac{V}{V_s} - 1} \right)$$

Where:

- t = operating time in seconds
- TMS = time Multiplier Setting
- V = applied input voltage
- V_s = relay setting voltage

NOTE: this equation is only valid for $\frac{V}{V_s}$ ratio < than 0.95 (Under Voltage) or ratio > than 1.1 (over voltage)

19. Connection Diagrams

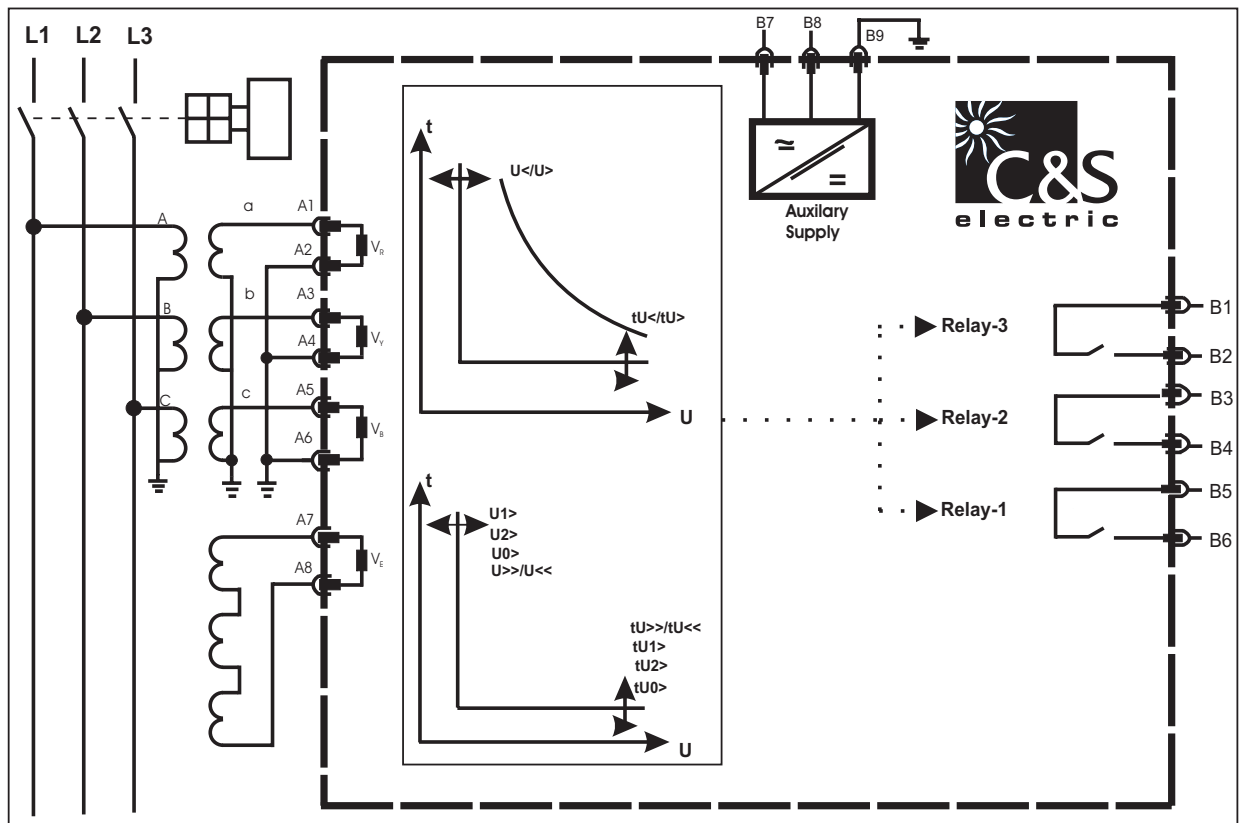

*External PT V_E (on A7 & A8) will be only in IRU-PRO-UOR

Star Connection in IRU-PRO

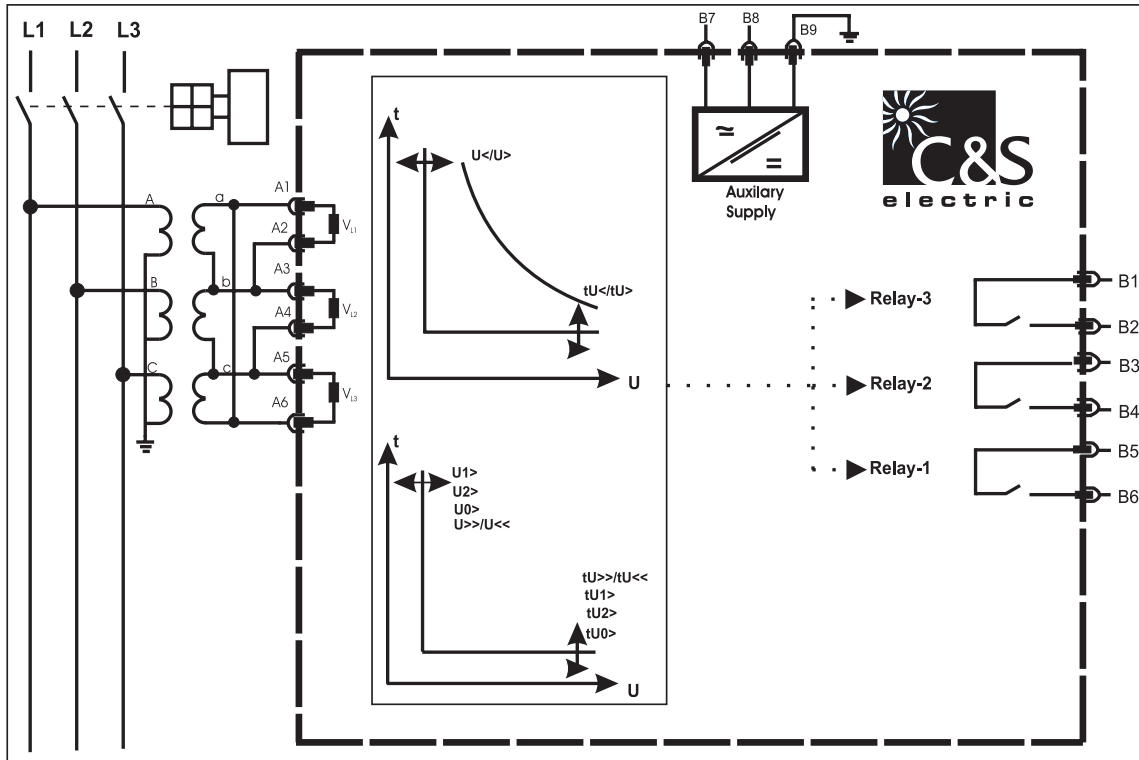

Delta connection in IRU-PRO

20. Cases & Dimensions

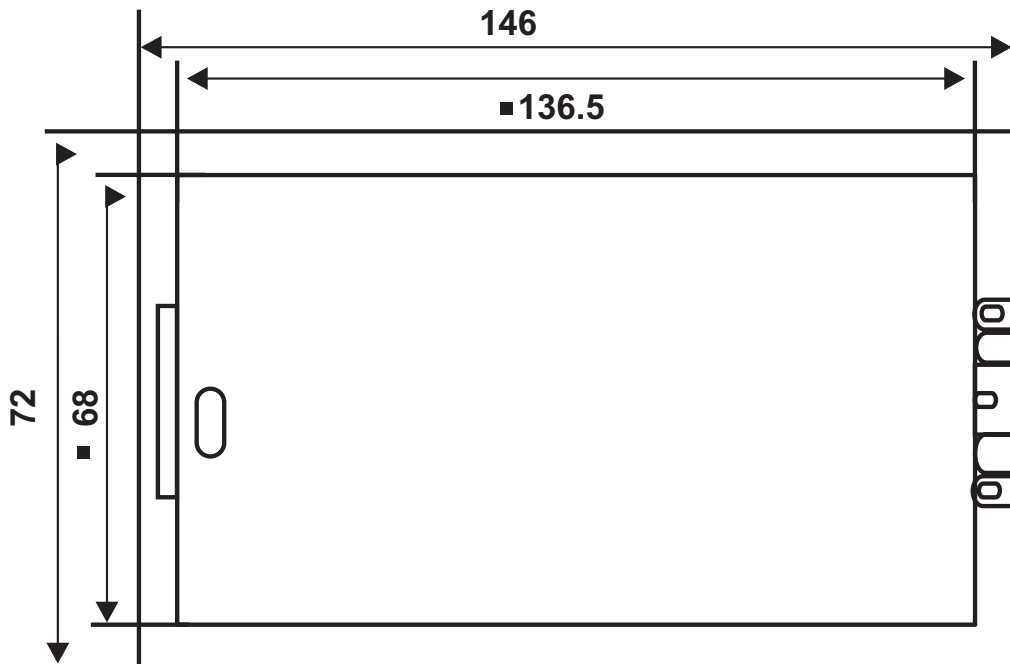

Cases & Dimensions

Side View

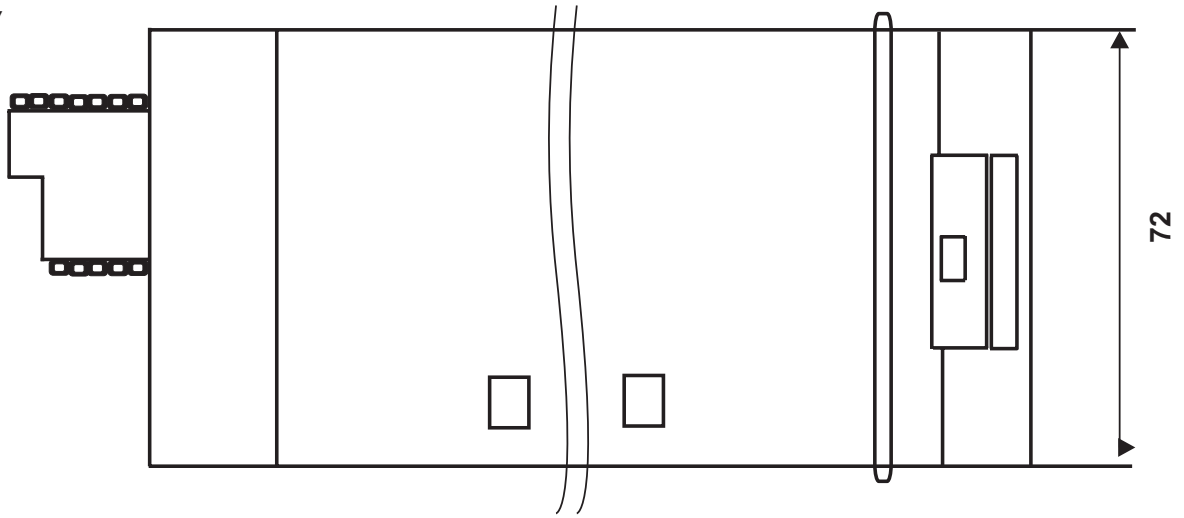

TOP View

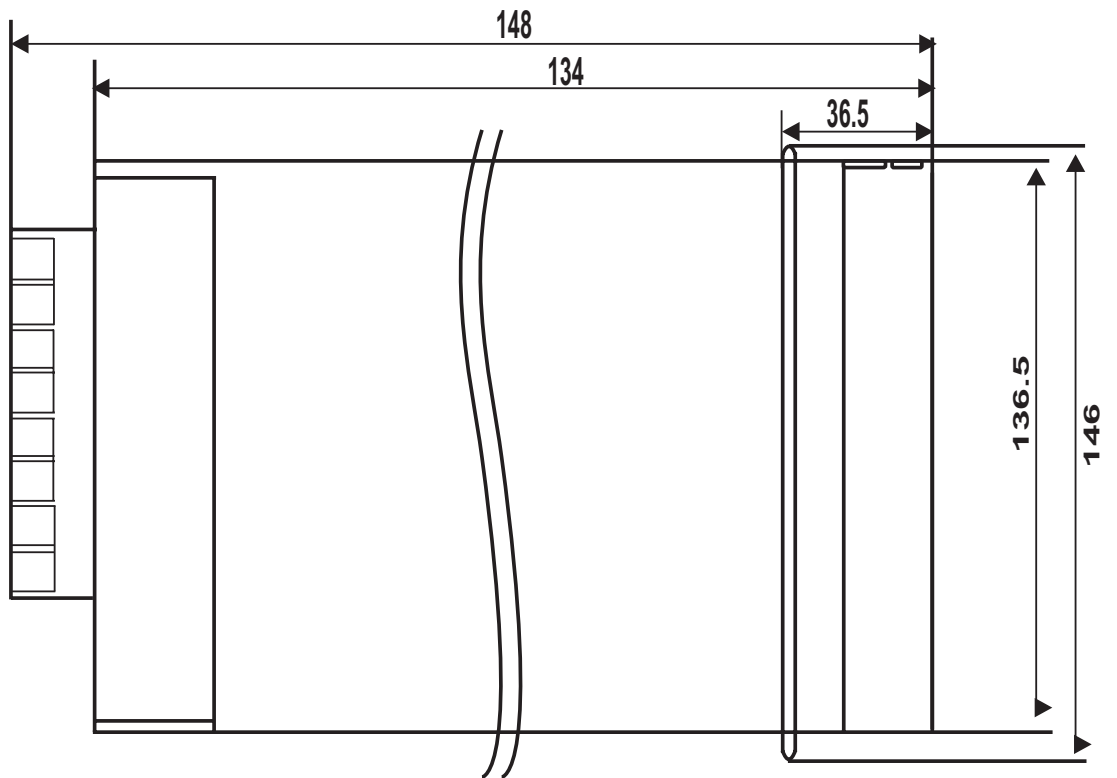

■ Cut out Dimensions
 Installation Depth : 175mm
 All dimensions in : mm

21. Ordering Information

IRU-PRO	Protection	Rated Voltage	Relay-2 Contact
Protection: a) 3VT Under voltage b) 3VT Over voltage c) 3 VT Under Over Voltage d) 3 VT + 1 Residual VT	— U — O — UO — UOR		
Rated Voltage (U_N) a) 110V b) 230V c) 400V		— 1 — 2 — 4	
Relay-2 Contact type a) NO - COMM b) NC - COMM			— O — C

Model Example:

IRU-PRO-UOR-1-C: 3VT+1Residual VT for U_N : 110V and Relay-2 contact type is NC -COMM with USB front interface & front end livelink software support

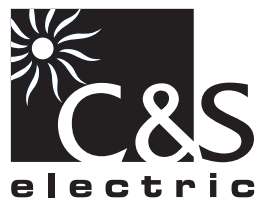

C&S Electric Limited

(Protection & Control Division)

44, Okhla Industrial Estate, New Delhi -110 020 (INDIA)
Phone : +91 11- 66602414, 30883745/54/64 Fax: +91 11- 66602413
E-mail: cspc@cselectric.co.in Web : www.cselectric.co.in

Marketing Offices :

AHMEDABAD: +91 79 30074534/35/36 FAX : +91 79 30074519 **BANGALORE:** +91 80 25586147, 25594939 FAX : +91 25584839
BHUBANESWAR : +91 674 2507265 FAX : +91 674 2507265 **CHANDIGARH :** +91 172 272613, 3062624 FAX : +91 172 2726153
CHENNAI : +91 44 39180531/32/33/34 FAX:+91 44 39180514 **DELHI :** +91 11 30838822-25 Fax:+91 11 30838826 **HYDERABAD:** +91 40 27813003
FAX : +91 40 27812987 **KOLKATA :** +91 33 22275850/51 FAX : +91 33 22275849 **MUMBAI :** +91 22 24114727/28 FAX : +91 22 24126631
NAGPUR : +91 712 5616651 FAX : +91 712 5616651 **PUNE :** +91 20 30283244/45 FAX : +91 20 30283245 **RAIPUR :** +91 771 320852433/34