

We touch your **electricity** everyday!

CSEnEX-I 100/101 Intelligent Measuring and Protection Device

CSEnEX
Series



Catalogue

INDEX

S.No.	Description
1.	Introduction
2.	Features
3.	Application
4.	Hardware
5.	Protection Features
6.	Functional Diagram
7.	Fault Recording
8.	Event Recording
9.	Human Machine Interface
10.	Communication
	10.1 Rear Communication
	10.2 Front Communication
11.	Setting Ranges
12.	Technical Data
13.	Type Test
14.	Technical Test
15.	Model Description Table
16.	TCS Diagram
17.	Connection Diagram
18.	Back Terminal Diagram
19.	Dimensional Details
20.	Ordering Information

1) Introduction

CSENEX Series offers a compact Multi-functional Over-current protection solution for Feeder, Generator, Motor & Transformer segment.

CSENEX-I Family of protective relays are numeric relays that provides multi protection and monitoring with reliable and fast protection solution in a single unit.

In this family of CSENEX series, the CSENEX-I is an feeder protection solution which has fast, sensitive and secure protection for feeder internal & external faults.

CSENEX-I offers different model based features to cover the wide range of user.

2) Features

- ❖ 1A & 5A rated CT input (site selectable).
- ❖ Three phase time over-current protection.
- ❖ Draw out with self CT shorting (Depend upon the Model).
- ❖ Three phase instantaneous protection.
- ❖ Earth time over-current and earth instantaneous over current.
- ❖ Circuit breaker failure detection.
- ❖ Trip circuit supervision.
- ❖ Event recorder.
- ❖ Fault recorder.
- ❖ Trip Counter.
- ❖ DI/DO programmable matrix.
- ❖ Communication (Local & Remote).

3) Application

The CSENEX-I relays have been designed for controlling, protecting and monitoring industrial, utility distribution networks and substations. They can also be used as part of a protection scheme for feeders, transformers and generators.

4) Hardware

- ❖ Micro controller based numeric design.
- ❖ Measures true RMS with DFT filter .
- ❖ 4 Current analog inputs.
- ❖ Max. 2 digital inputs.
- ❖ Max. 4 digital outputs.
- ❖ Alpha numeric (12 x 2) LCD.
- ❖ RS-485 & USB communication.
- ❖ 5 Push button on the front for MMI.

5) Protection Features

- ❖ Three phase time over current protection (51).
- ❖ Three phase instantaneous protection (50).
- ❖ Earth time over-current (51N).
- ❖ Earth instantaneous over-current (50N).
- ❖ Circuit breaker failure protection (50BF)
- ❖ Trip Circuit Supervision (74TC)
- ❖ Cold Load Pickup

6) Functional Diagram

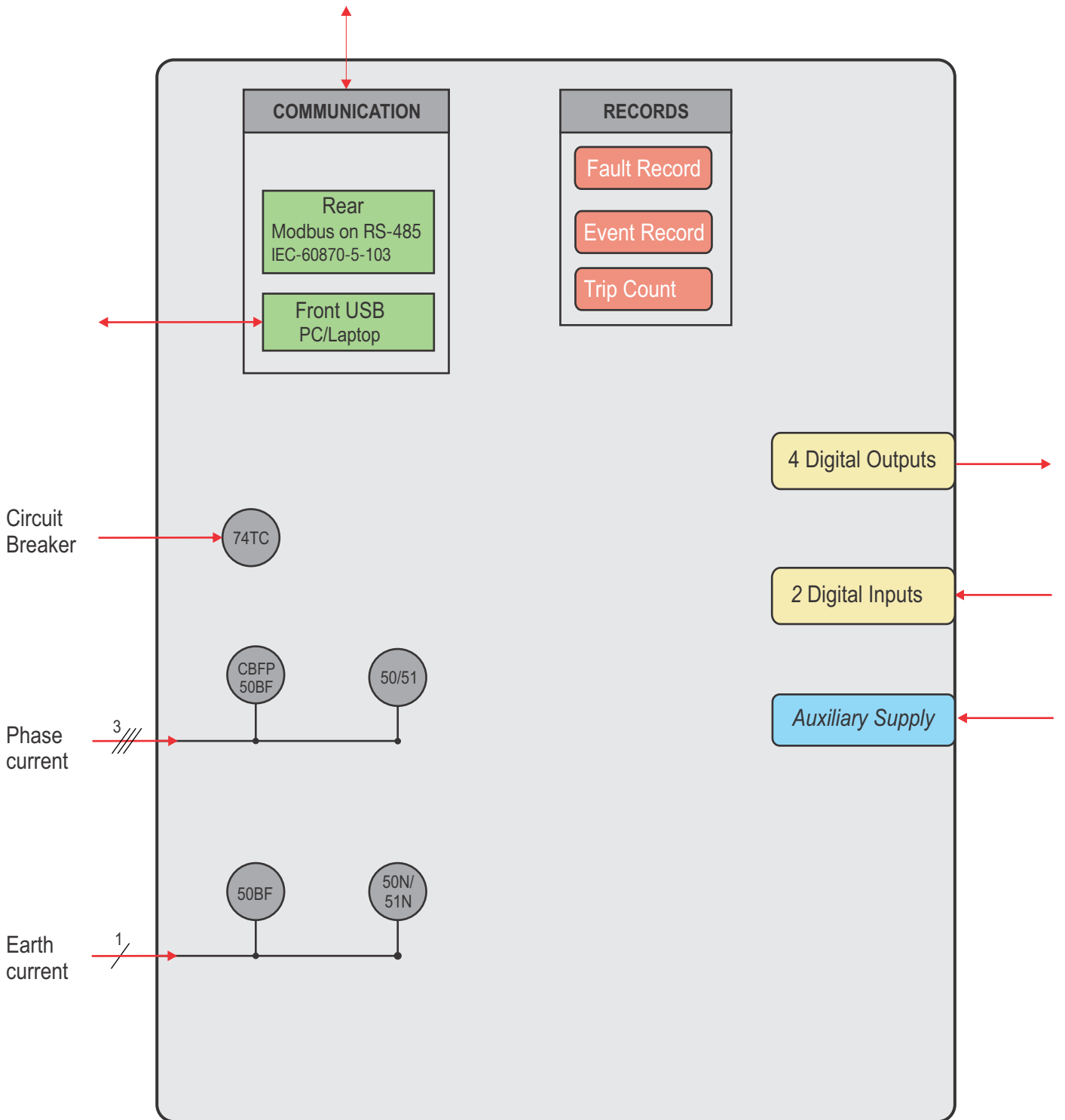

(Figure 1)

Protection Function

Three Phase Over-current Protection (50/51)

The independent two stages are available for phase fault protection. For $I >$ the user may independently select definite time delay or inverse time delay with different type of curves. The second Hi-Set stage can be configured with definite time only.

Earth Fault Protection (50N/51N)

The independent two stages are available for earth fault protection. For first stage ($I_{e >}$) the user can select definite time delay or inverse time delay with different type of curves. The second Hi-Set stage can be configured with definite time only.

Trip Circuit Supervision (74TC)*

This feature continuously supervises trip circuit of both pre closing and post closing conditions in circuit breaker. It detects tripping mechanism failure like circuit breakage contact degeneration in wires, contacts and coils.

Circuit Breaker Failure Protection (50 BF)

The CB Failure Protection is based on supervision of phase and earth currents after tripping events. The test criterion is whether all phase currents have dropped to less than 5% of I_n within t_{CBFP} . If one or more of the phase currents have not dropped to specified current within this time, CB failure is detected and the assigned output relay is activated.

Harmonic based Protection Blocking

To avoid any nuisance tripping, CSENEX-I provides harmonic detection & protection blocking feature. Relay will hold the tripping for a set time, If harmonic is present with protection pickup. Blocking time & harmonic selection is configurable in the relay.

Note: Harmonics is detected based on presence for at least 2 cycles.

Protection blocking due to harmonics is active, when percentage of harmonics present is more than 25% of fundamental current.

Cold Load Pickup

This function aims to avoid non-desired trips in the following situation: after being the line de-energized for a period of time and re-energized later, the load exceed the protection setting without the presence of a fault. This may be due to the fact that the “off” period of all the loads (furnaces, heaters, coolers etc.) is elapse and they are all connected at the same time, producing a strong inrush current in the line, but which can be supported within certain time. This phenomenon can occur not only at the moment of the breaker manual closing, after having remained open for a certain time, but also with the breaker permanently closed due to the operation of another upstream breaker.

What the function does is detecting when those conditions are given and changing the tripping settings during a programmable time.

The function is activated when the current in the 3 phases is below 0.08A, then the programmed time starts to run to determine that the load is “cold” (this time can be 0, what means that any circuit breaker opening could lead to the cold load situation). Once that time has expired and the current has not exceed again 0.15A, the protection usual setting values are replaced by the cold load pickup ones. When any of the phase current exceed 0.15A a counter with programmable time starts, during which the setting are the cold load pickup ones. When expiring this time, the settings are again the usual ones.

7) Fault Recording

CSENX-I records last 10 faults in its non volatile memory with it's time stamp. Each record has the following information:

Fault Format
 [F] IL1 : 00.00A
 [F] IL2 : 00.00A
 [F] IL3 : 00.00A
 [F] Ie : 00.00A
 HOUR MIN : HH:MM
 SEC mSEC : Sec:mSec
 F-TYPE : FAULT TYPE

Where

[F][ILx] Magnitude of phase current's.

[F]Ie Magnitude earth fault current's

F-Type Origin of fault (over current, negative phase sequence, etc.) (See Figure 2)

whenever the available memory space is exhausted the new fault automatically over writes the oldest fault. When the relay trips the description of fault in the feeder will appears on the LCD screen automatically and by pressing 'i'key one can easily get all the detailed information of that fault.

The user can view the fault record either via the front USB interface software or remotely via the RS-485 communication.(See figure-2)

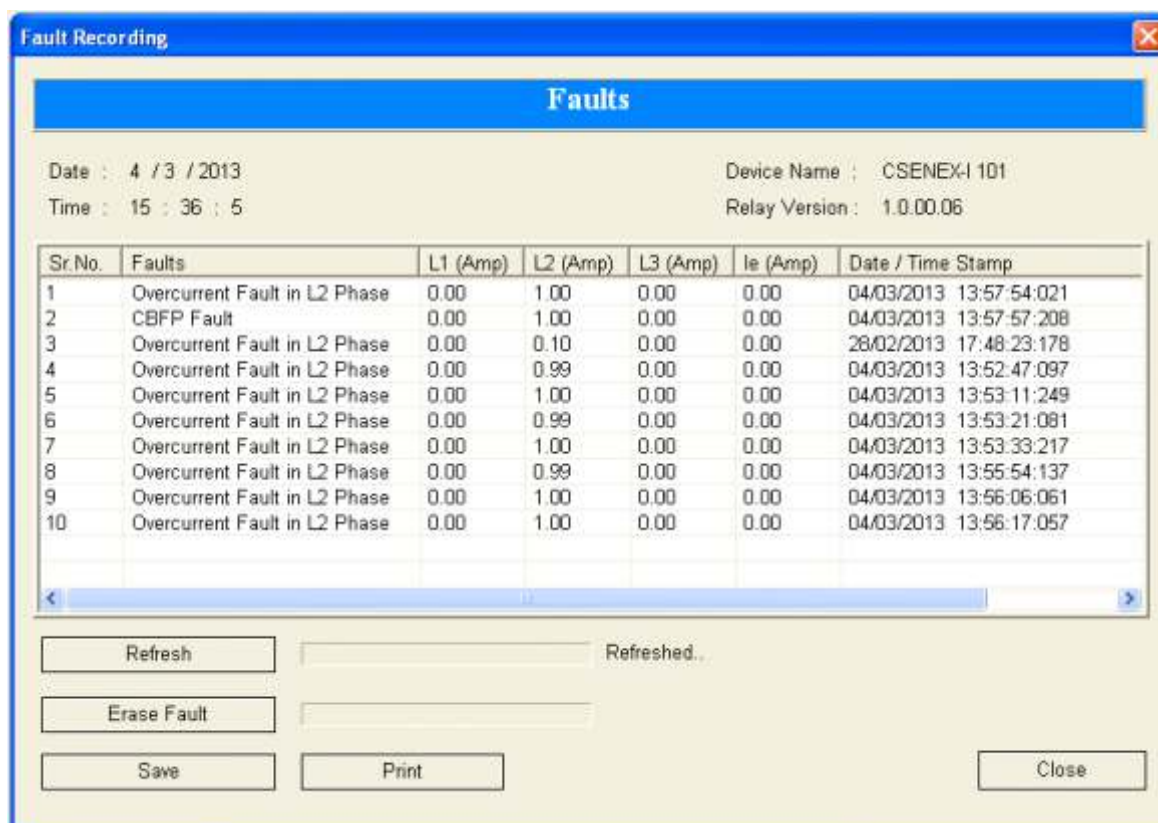

Date : 4 / 3 / 2013
 Time : 15 : 36 : 5
 Device Name : CSENX-I 101
 Relay Version : 1.0.00.06

Sr.No.	Faults	L1 (Amp)	L2 (Amp)	L3 (Amp)	Ie (Amp)	Date / Time Stamp
1	Overcurrent Fault in L2 Phase	0.00	1.00	0.00	0.00	04/03/2013 13:57:54:021
2	CBFP Fault	0.00	1.00	0.00	0.00	04/03/2013 13:57:57:208
3	Overcurrent Fault in L2 Phase	0.00	0.10	0.00	0.00	26/02/2013 17:48:23:178
4	Overcurrent Fault in L2 Phase	0.00	0.99	0.00	0.00	04/03/2013 13:52:47:097
5	Overcurrent Fault in L2 Phase	0.00	1.00	0.00	0.00	04/03/2013 13:53:11:249
6	Overcurrent Fault in L2 Phase	0.00	0.99	0.00	0.00	04/03/2013 13:53:21:091
7	Overcurrent Fault in L2 Phase	0.00	1.00	0.00	0.00	04/03/2013 13:53:33:217
8	Overcurrent Fault in L2 Phase	0.00	0.99	0.00	0.00	04/03/2013 13:55:54:137
9	Overcurrent Fault in L2 Phase	0.00	1.00	0.00	0.00	04/03/2013 13:56:06:061
10	Overcurrent Fault in L2 Phase	0.00	1.00	0.00	0.00	04/03/2013 13:56:17:057

Buttons: Refresh, Erase Fault, Save, Print, Close

(Figure 2) (Fault Data Recording on PC software)

8) Event Recording

The unit stores in non volatile memory the last 16 events. When the available memory space is exhausted, the new event automatically overwrites the oldest event which can be retrieved from a PC, with the following format:

```

EVENT      :          EVENT NUMBER
HOURL      :          HH:MM
SEC mSEC   :          SEC:mSEC
DATE       :          DD/MM/YY
  
```

The user can view event records via the front USB interface software (See Figure 3)

* Description of event number available in event list or in front end software

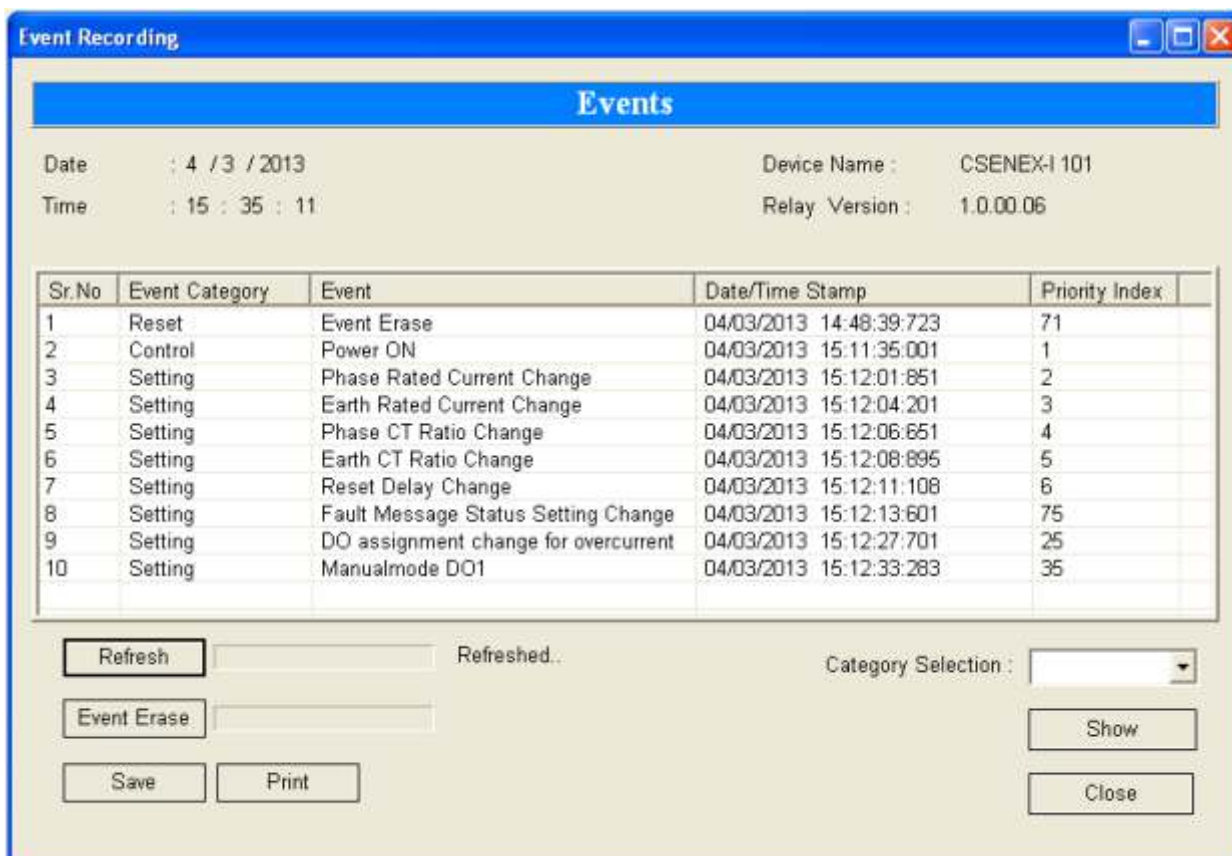

Sr.No	Event Category	Event	Date/Time Stamp	Priority Index
1	Reset	Event Erase	04/03/2013 14:48:39.723	71
2	Control	Power ON	04/03/2013 15:11:35.001	1
3	Setting	Phase Rated Current Change	04/03/2013 15:12:01.851	2
4	Setting	Earth Rated Current Change	04/03/2013 15:12:04.201	3
5	Setting	Phase CT Ratio Change	04/03/2013 15:12:06.651	4
6	Setting	Earth CT Ratio Change	04/03/2013 15:12:08.895	5
7	Setting	Reset Delay Change	04/03/2013 15:12:11.108	6
8	Setting	Fault Message Status Setting Change	04/03/2013 15:12:13.601	75
9	Setting	DO assignment change for overcurrent	04/03/2013 15:12:27.701	25
10	Setting	Manualmode DO1	04/03/2013 15:12:33.283	35

(Figure 3) (Event Data Recording on PC Software)

Output Contacts

```

No. of digital outputs      :    4 (DO1, DO2, DO3, DO4)
                               [2 Change Over, 2 Normal Open]
Type of outputs             :    Relay
Programmable (DO Assignment) :    Yes
Relay reset type           :    Programmable (Auto/Manual)
  
```

Input Contacts





```

No of digital inputs       :    2 (DI1, DI2)
Programmable (DI Assignment) :    Programmable
  
```

9) Human Machine Interface

It comprises of bright LCD display

- ❖ Four push switches for setting values of normal tripping characteristics and other operations for local access.
- ❖ One 'RESET' push switch.
- ❖ One push switch for the functions assigned in the 'HMI'.
- ❖ Sixteen LEDs for pickup or tripping on fault and event in any phase.

Keys	Manual Key
	is used as intelligent key to see the details of last fault and Relay status.
	is used as a "ENTER" key.
	is used to manual reset (after pressing for 2 sec)
	is used to scroll in downward direction.
	is used to scroll in upward direction.



(Figure 4) (HMI)

10) Communication (Local & Remote)

The unit has:

- ❖ 1 Front USB port for direct connection to a PC
- ❖ 1 Rear RS-485 communication port

10.1) Rear Communication * (Model dependent)

The protocol for the rear port is MODBUS-RTU, IEC-60870-5-103.

10.2) Front Communication

The entire setting, Fault & Event are available on 'A' type USB (female) interface with CSE LIVELINK with saving & printing option. This unit also has Front-end Live Link simulation support for testing of relay even without any three phase injection source.

11) Setting Ranges

CSENEX-Ixxx Setting

Over Current & Earth Protection

S. No	Parameter	Display	Setting Range		Step Size	Default Setting
			Min.	Max.		
1	Phase over-current characteristics	PCh			DEFT/EINV/VINV /LINV/NINV1.3/ NINV3.0/NINV0.6	DEFT
2	Earth over-current Characteristics	ECh			DEFT/EINV/VINV /LINV/NINV1.3/ NINV3.0/NINV0.6	DEFT
3	Phase over-current low set pickup setting	I>	0.05xI _p	4.0xI _p	0.01xI _p	EXIT
	Phase over-current definite timing	t>	0.1 Sec	150 Sec	0.01Sec	0.10 Sec
	Phase over-current inverse timing	ti>	0.01	1.50	0.005	0.05
4	Phase over-current hi-set pickup setting	I>>	0.5xI _p	30xI _p	0.1xI _p	EXIT
	Phase over-current hi-set definite timing	t>>	0.03 Sec	20 Sec	0.01Sec	0.10 Sec
5	Earth over-current low set pickup setting	Ie>	0.05xI _n	2.5xI _n	0.01xI _n	EXIT
	Earth over-current low set definite timing	te>	0.03 Sec	150 Sec	0.01Sec	0.10 Sec
	Earth over-current low set inverse timing	tie>	0.01	1.50	0.005	0.05
6	Earth over-current hi-set pickup setting	Ie>>	0.5xI _n	8xI _n	0.05xI _n	EXIT
	Earth over-current hi-set definite timing	te>>	0.03 Sec	20 Sec	0.01 Sec	0.10 Sec

Very Inverse
$$t = \frac{13.5}{(I/IS) - 1} \text{ ti [s]}$$

Extremely Inverse
$$t = \frac{80}{(I/IS)^2 - 1} \text{ ti [s]}$$

Long time Inverse
$$t = \frac{120}{(I/IS) - 1} \text{ ti [s]}$$

Normal Inverse 3.0/1.3/0.6
$$t = \frac{0.14/0.061/0.028}{(I/IS)^{0.02} - 1} \text{ ti [s]}$$

Where $t =$ Tripping time $ti =$ Time multiplier
 $I =$ Fault current $IS =$ Setting value of current

For Current Range 0.2 to 20xI_n:

Trip timing Accuracy : VINV / NINV 3.0 / 1.3 : +5% OR +30mSec (whichever is higher)
 EINV / NINV 0.6 / LINV : +7.5% OR +30mSec (whichever is higher)

For Current Range 0.05 to 0.2xI_n:

Trip timing Accuracy : VINV / NINV 3.0 / 1.3 : +20% OR +40mSec (whichever is higher)
 EINV / NINV 0.6 / LINV : +20% OR +40mSec (whichever is higher)

Note = * Availability as per model selection.

Trip Circuit Supervision Protection*

S.No.	Parameter	Display	Setting Ranges		Step Size	Default
			Min	Max		
1	TCS	t_TCS	0.03	2	0.01	EXIT

Circuit Breaker Failure Protection

S.No.	Parameter	Display	Setting Ranges		Step Size	Default
			Min	Max		
1	CBFP	t_CBFP	0.03	2	0.01	EXIT

DO Reset

S.No.	Display	Setting Ranges	Default
1	DO-1	Auto / Manual	Auto
2	DO-2	Auto / Manual	Auto
3	DO-3	Auto / Manual	Auto
4	DO-4	Auto / Manual	Auto

DI Assignment *

S.No.	Parameter	Display	Min	Max	Step Size	Default
1	Circuit Breaker Close	CB close	DI1	Exit	-----	-----
2	Circuit Breaker Open	CB open	DI1	Exit	-----	-----

Erase Record

S.No.	Parameter	Display	Min	Max	Step Size	Default
1	Event Erase	Events	NO	YES	-----	NO
2	Fault Erase	Faults	NO	YES	-----	NO
3	Trip Counter Erase	TRP_CNT	NO	YES	-----	NO

Harmonic Blocking *

S.No.	Parameter	Display	Min	Max	Step	Default
1	Phase harmonic	Ph_Har	NO	YES	-----	NO
2	Earth Harmonic	ET_Har	NO	YES	-----	NO
3	Phase blocking time	t_Ph	0.10	20.00	-----	0.10
4	Earth blocking time	t_Et	0.10	20.00	-----	0.10

DO Assignment

S.No	Parameter	Display	Min	Max	Default
1	Phase over-current low set	I>	1	1234	----
2	Phase over-current hi-set	I>>	1	1234	----
3	Earth over-current low set	E>	1	1234	----
4	Earth over-current hi-set	E>>	1	1234	----
5	Self supervision	Slfsup	1	1234	----
6	Trip Circuit protection	TCS	1	1234	----
7	Circuit breaker failure protection	CBFP	1	1234	----

Note = * Availability as per model selection.

Cold Load Pickup Setting

S.No	Parameter	Display	Min	Max
1	Cold Load Pickup enable	CLP PKP	NO	YES
2	Cold Load Short Circuit Setting	I>>	0.50 xlp	30.0 xlp
3	Cold Load Short Circuit Time	t>>	0.03 s	20.00 s
4	Cold Load Earth Hi-set Setting	Ie>>	0.50 xIn	8.0 xIn
5	Cold Load Earth Hi-set Time	te>>	0.03 s	20.00 s
6	Cold Load Time	tcl	0.00 s	100.00 s
7	Cold Load Pickup Time	tac	0.00 s	100.00 s

Common Setting: (These are the settings common for all protections)

S.No.	Parameter	Display	Setting Range		Step Size	Default Setting
			Min.	Max.		
1.	Rated phase current *	I _p	1 A	5 A	-----	1 A
2.	Rated earth current *	I _n	1 A	5 A	-----	1 A
3.	Phase CT ratio	P-CTR	1	9999	1	1
4.	Earth CT ratio	E-CTR	1	9999	1	1
5.	Reset Delay	Rstdl	0 Sec	20 Sec	0.1sec	0
6.	Fault Message Status	F-Stats	NO	YES	-----	NO

Rear port communication setting

(*Availability as per model selection)

RS-485/RS-232 Communication		
Protocol	:	MODBUS RTU, IEC-60870-5-103
Baud rate selection (programmable)	:	9600/19200/38400 bps
Parity selection (programmable)	:	Even / Odd / None
Stop bit	:	1 Bit
Data bit	:	8 Bit data
Remote Address (programmable)	:	(1 to 247)
Cable required for interface	:	Two wire twisted shielded cable

USB Communication		
Protocol	:	CSE proprietary protocol: available with front software
Baud rate	:	19200 bps
Cable required for interface	:	USB cable type (A to A)

Auxiliary Supply

Auxiliary Voltage Range	:	For 'L' Model	18V-60V DC
		For 'W1' Model	18V-150V DC
		For 'H' Model	85V-280V AC / 110V-300V DC
Supply Range for Digital Input	:	For 'L & H' Model	24V above AC/DC
Power Consumption	:	Quiescent approx. 3W	Operating approx. <7W

Measurement Accuracy

S.No	Quantity	Range	Frequency Range	Accuracy
1	Current	1.0 - 30 xI _p	50 Hz	+2%

12) Technical Data

Measuring Inputs

Rated Data	Rated current I_p : 1A or 5A Rated frequency F_n : 50 Hz/60Hz
Drop out to Pickup Ratio	>96%
Power consumption in current circuit	At $I_p=1A$ 0.2 VA At $I_p=5A$ 0.4 VA
Thermal withstand capability in current circuit	Dynamic current withstand (half wave): $250 \times I_p$ for 1 Sec : $100 \times I_p$ for 10 Sec : $30 \times I_p$ continuously : $4 \times I_p$

13) Type Test

DESIGN STANDARD	
Specified ambient service temp. range	: VDE 04355 part 303, IEC 255-4, BS 142
For storage	: $40^{\circ}C$ to $+ 85^{\circ}C$
For operation	: $-20^{\circ}C$ to $70^{\circ}C$
Environmental protection class 'F' as per DIN 40040 and per DIN IEC 68, part 2.3	: relative humidity 95% at 40 deg C for 56 days.
Isolation test voltage, inputs and outputs between themselves and to the relay frame as per VDE 0435, part 303	: 2.5 KV (eff.) / 50 Hz, 1 min.
Impulse test voltage, inputs and outputs between themselves and to the relay frame as per VDE IEC 0435, part 303	: 5 KV, 1.2/50ms, 0.5J
High frequency interference test voltage, inputs and outputs between themselves and to the relay frame as per DIN IEC 255, part 22-1	: 2.5 KV/1MHz
Electrical fast transient (burst) test as per DIN VDE 0843 part 4	: 4KV / 2.5 kHz, 15ms
Radio interference suppression test as per DIN VDE 57 871	: Limit value class 'B'
Electrostatic discharge (ESD) test as per DIN VDE 0843 part 2	: 8 KV
Radiated electromagnetic field test as per VDE 0843 part2	: 10 V/m

14) Technical Test

Shock	:	As per DIN IEC 41 B (CO) 38: class 1
Vibration	:	As per DIN IEC 41 B (CO) 35: class 1
Protection-Front Panel	:	IP-54
Protection-Rear Panel	:	IP-00
Weight	:	Approx. 1.5 Kg

Relay Contact Rating

Contact rating	
Contact relay	Dry contact Ag Ni
Make current	Max. 30A & carry for 1S
Carry capacity	6A continuous for All contacts Rated voltage: 300V AC/ 30V DC
Breaking characteristics	
Breaking capacity AC	1500VA resistive 1500VA inductive (PF=0.5) 220V AC, 6A (cos ϕ \leq 0.6)
Breaking capacity DC	135V DC, 0.3A (L/R=30ms) 250V DC, 50W resistive or 25W inductive (L/R=40ms)
Operation time	<10ms
Durability	
Loaded contact	30000 operation minimum
Unloaded contact	10000 operation minimum

Over-voltage category : II
 Insulation voltage : 300V
 Pollution Degree : 2
 IP 54 from Front

15) Model Selection Table

Function	ANSI	NEX-I-100	NEX-I-101
CT inputs	–	4	4
Over current	50/51	✓	✓
Earth fault	50N/51N	✓	✓
CBFP	50BF	✓	✓
Trip circuit	74TC	x	✓
Cold Load Pickup	62 CLD	✓	✓
Inrush blocking	51H	x	✓
Digital input	–	x	2
Digital output	–	4	4
Fault record	–	10	10
Event record	–	16	16
Selection of 1/5A	–	○	○
Front communication	–	✓	✓
Rear comm. (RS-485/RS-232)	–	○	○

○ : Optional based on Ordering Information

16) Trip Circuit Supervision Diagram

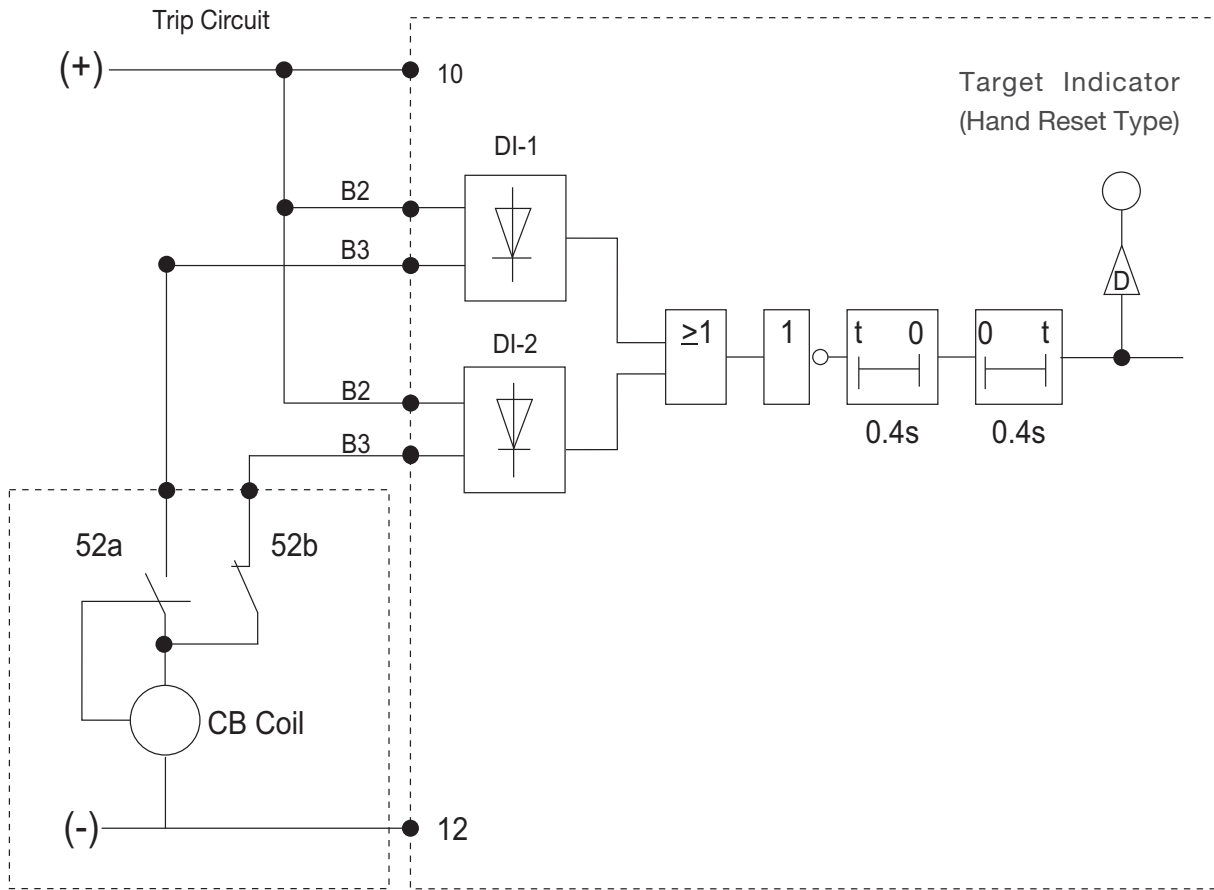

(Figure 5) (Trip Circuit Supervision Function)

17) Connection Diagram

Terminal Connection Details

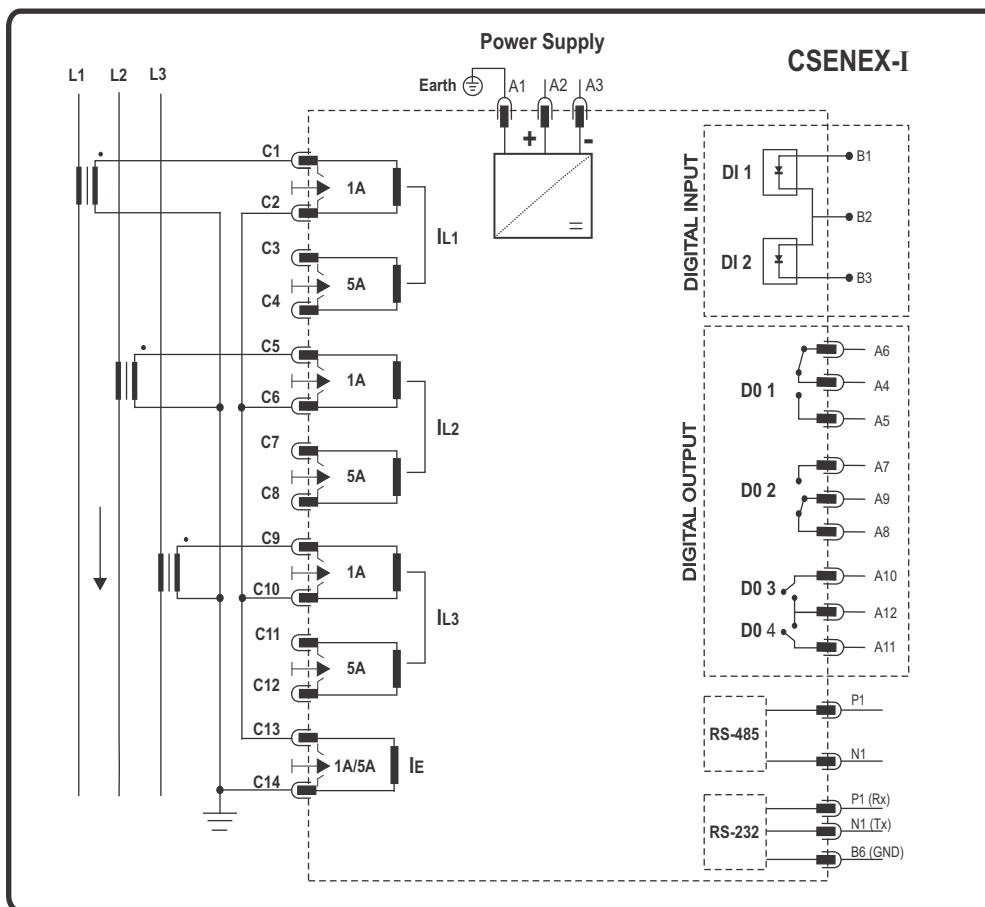

(1A & 5A common model)

(Figure 6)

Terminal Description

Terminal Name	Terminal Description
A1	: Auxiliary Supply Earth
A2-A3	: Auxiliary Supply (A2: + & A3: -)
P1-N1	: For RS-485: P1(Data+ / A), N1(Data- / B) For RS-232: P1(Rx), N1(Tx)
B6	: GND Terminal for RS-232
A12-A11	: Potential free Digital Output 4
A12-A10	: Potential free Digital Output 3
A7-A9-A8	: Potential free Digital Output 2 (change over)
A6-A4-A5	: Potential free Digital Output 1 (change over)
B1-B2	: Potential Digital Input 1
B3-B2	: Potential Digital Input 2
C1-C2	: CT Terminal for Phase current input (1A) L1
C3-C4	: CT Terminal for Phase current input (5A) L1
C5-C6	: CT Terminal for Phase current input (1A) L2
C7-C8	: CT Terminal for Phase current input (5A) L2
C9-C10	: CT Terminal for Phase current input (1A) L3
C11-C12	: CT Terminal for Phase current input (5A) L3
C13-C14	: CT Terminal for Earth current input (1A / 5A)

Connection Diagram

Terminal Connection Details

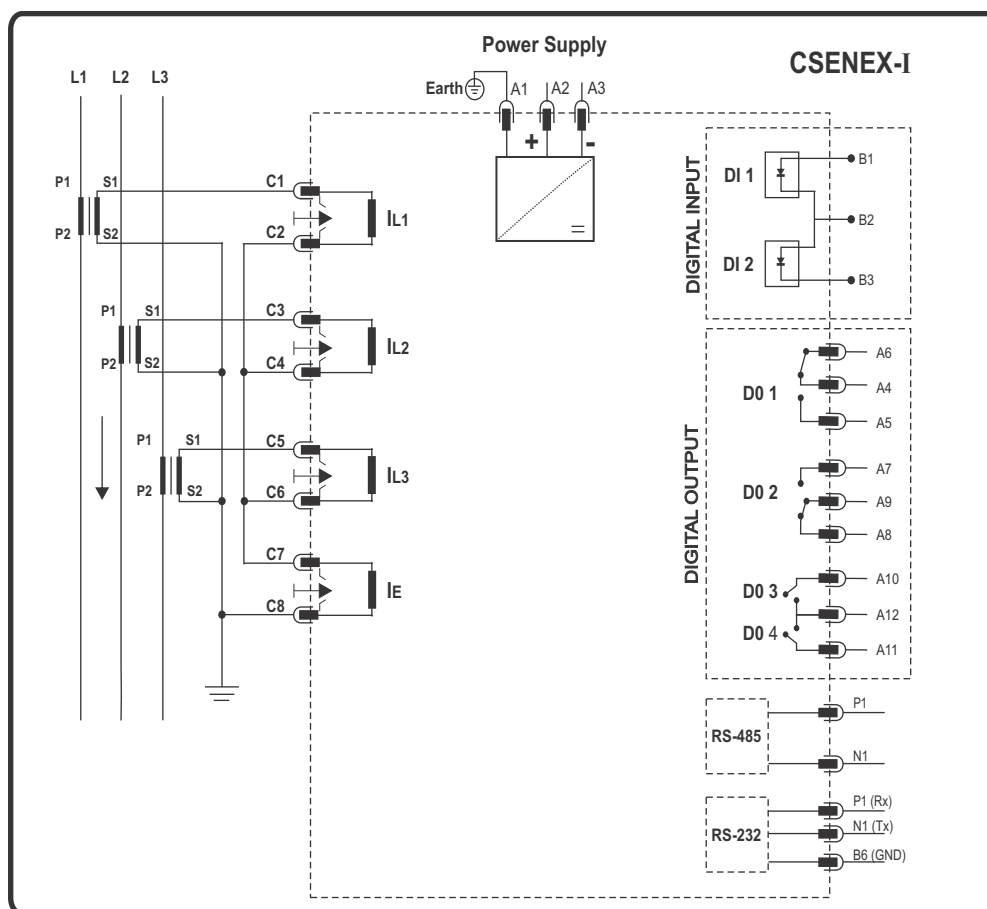

(1A or 5A ordering based model)

(Figure 7)

Terminal Description

Terminal Name	Terminal Description
A1	: Auxiliary Supply Earth
A2-A3	: Auxiliary Supply (A2: + & A3: -)
P1-N1	: For RS-485: P1(Data+ / A), N1(Data- / B) For RS-232: P1(Rx), N1(Tx)
B6	: GND Terminal for RS-232
A12-A11	: Potential free Digital Output 4
A12-A10	: Potential free Digital Output 3
A7-A9-A8	: Potential free Digital Output 2
A6-A4-A5	: Potential free Digital Output 1
B1-B2	: Potential Digital Input 1
B3-B2	: Potential Digital Input 2
C1-C6	: CT Terminal for Phase current inputs L1(C1-C2), L2(C3-C4), L3(C5-C6)
C7-C8	: CT Terminal for Earth current input

18) Back Terminal Diagram

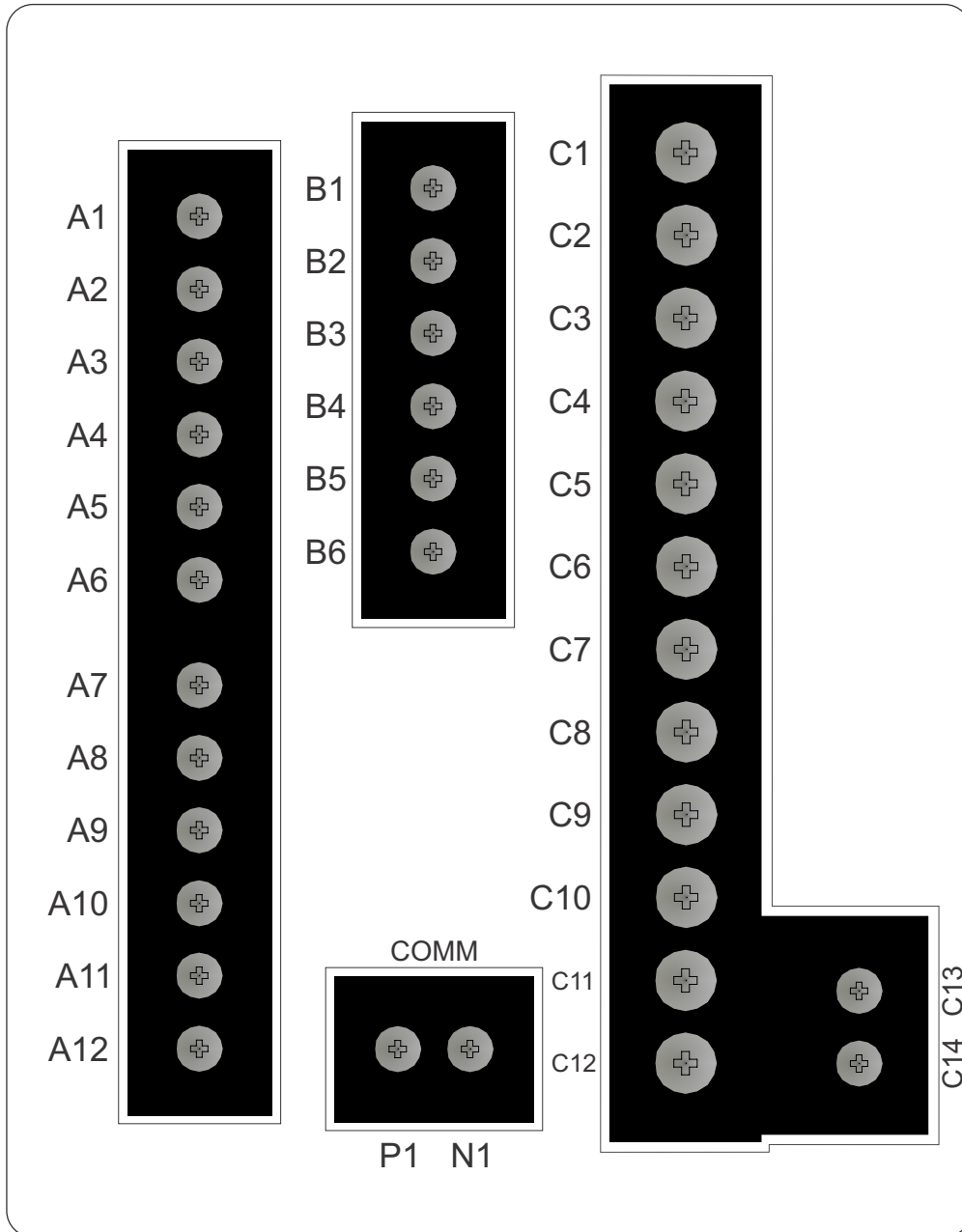

(Figure 8)

19) Dimensional Details

Panel cutout dimensions: WxH = 112.0x145.0mm

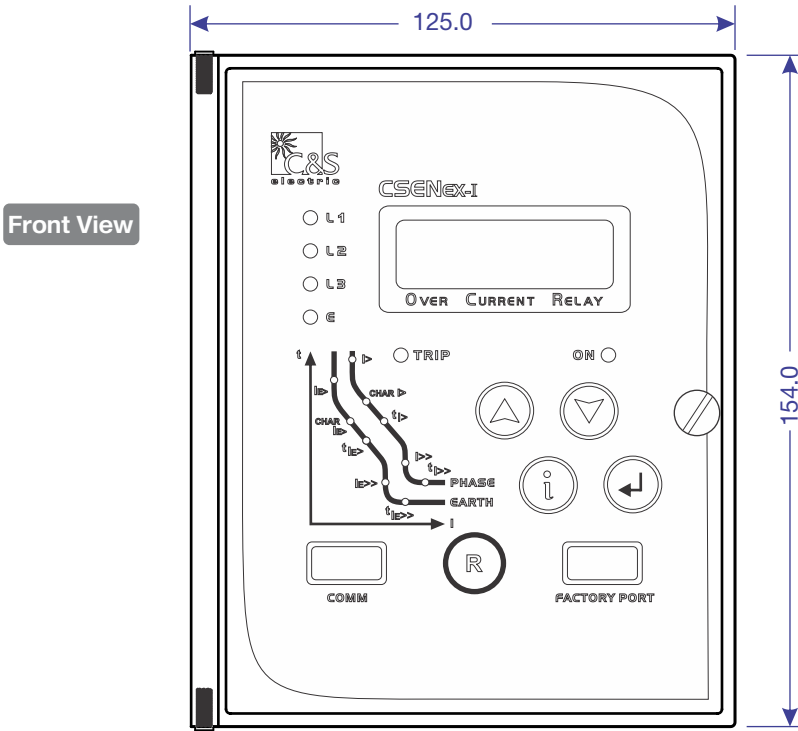

(Figure 9)

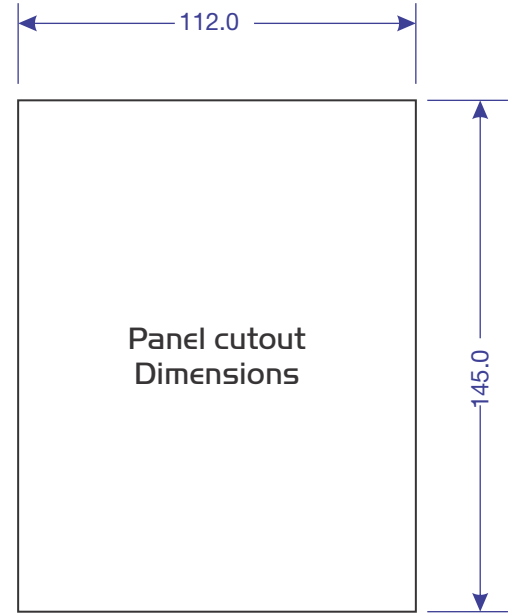

(Figure 10)

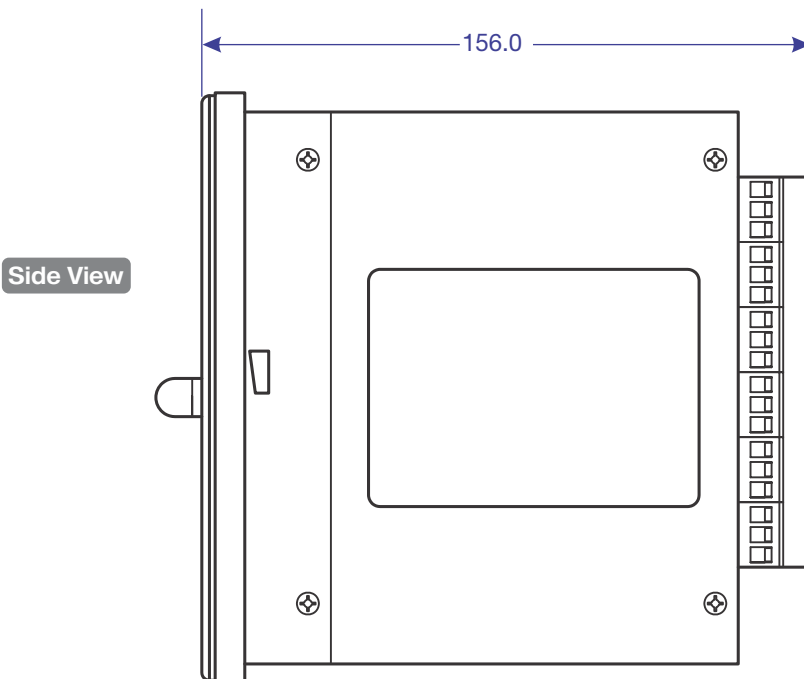

(Figure 11)

20) Ordering Information

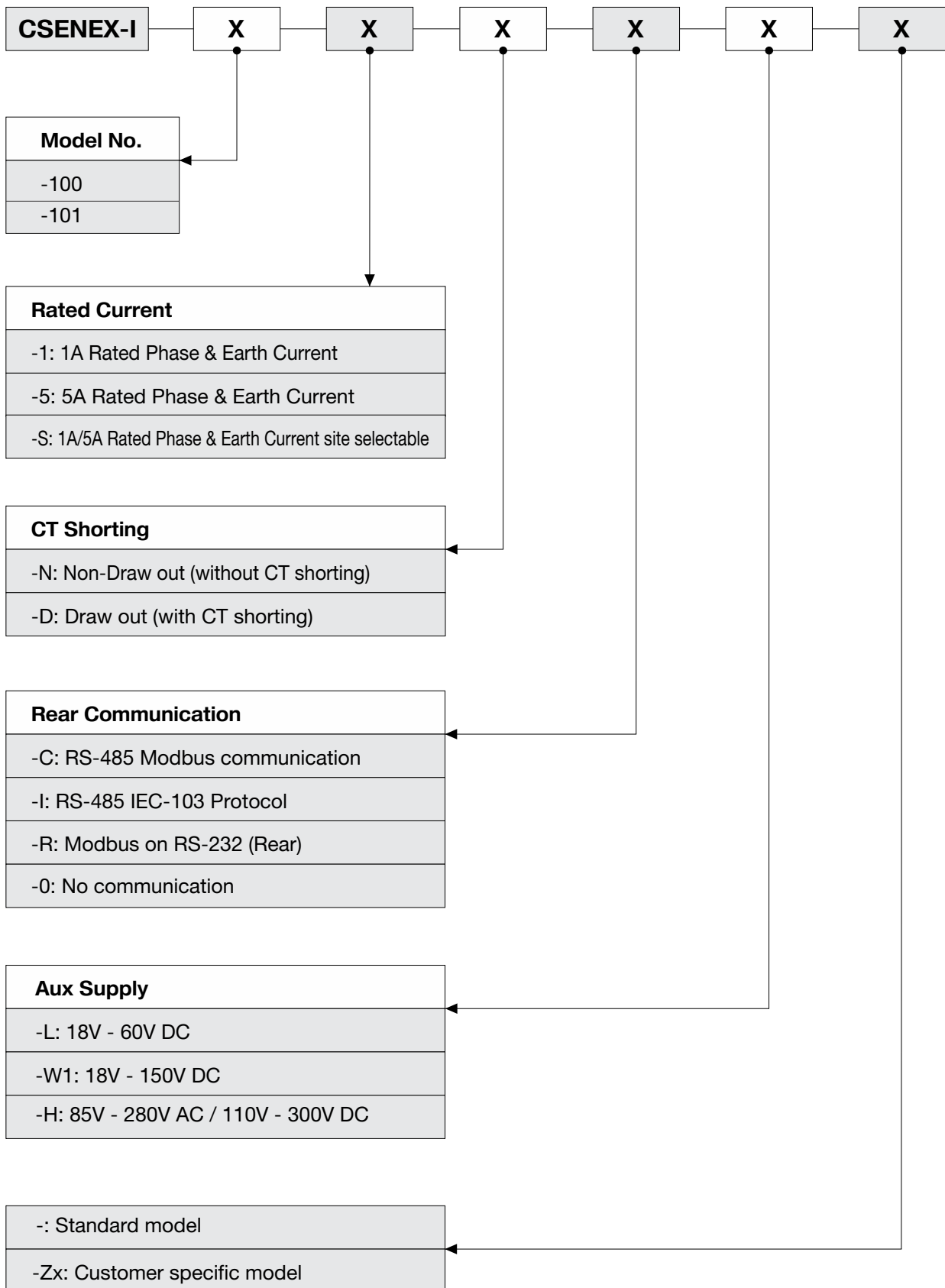

EXAMPLE: CSENX-I-100-1-N-C-L-Zx

Revision History

S.No.	Rev.No.	Details	Date
01	14	Inclusion of TCS Diagram	05.08.14
02	15	Inclusion of Cold Load Pickup Description & Table	02.09.14
03	16	Inclusion of RS-232 Communication in Conn. Diagram, Term. Description & Ordering Information	01.10.14
04	17	Change in TCS Diagram	10.09.15

For further information, please contact:

C&S Electric Ltd.
(Protection & Measurement Devices)

C-60, Wing-A, Phase-II, Noida - 201 305, Dist.: Gautam Budh Nagar (U.P) INDIA
Phone : +91-120-3057700/01, Fax: +91-120-3057704, E-mail: cspc@cselectric.co.in

Issue Date: 10.10.12

Rev. No: 17

Rev. Date: 10.09.15

Branch office

Branch	Phone	Fax	E-mail
Ahmedabad:	+91 79 30074534/35/36	+91 79 30074519	cspc.ahmedabad@cselectric.co.in
Bangalore:	+91 80 3057 0372/73, 3057 0347	+91 2558 4839	cspc.bangalore@cselectric.co.in
Bhubaneswar:	+91 674 2507265	+91 674 2507265	cspc.bhubaneswar@cselectric.co.in
Chennai:	+91 44 3918 0531-35	+91 44 39180514	cspc.chennai@cselectric.co.in
Cochin:	+91 0484 3071717	+91 0484 3071716	cspc.cochin@cselectric.co.in
Delhi:	+91 11 30838822-25	+91 11 30838826	cspc.delhi@cselectric.co.in
Hyderabad:	+91 40 3918 2496/97	+91 40 3910 3631	cspc.hyderabad@cselectric.co.in
Kolkata:	+91 33 22275850/51	+91 33 2227 5849	cspc.kolkata@cselectric.co.in
Mumbai:	+91 22 30487146/47/48	+91 22 2412 6631	cspc.mumbai@cselectric.co.in
Pune:	+91 20 30283244/45	+91 20 30283244	cspc.pune@cselectric.co.in