

We touch your **electricity** everyday!

## CSDPR-V2-200-P

Intelligent measuring & protection device



Catalogue



Multi Powered  
Current Protection Relay

# Index

- 1 Introduction
- 2 Design
  - 2.1 Operation
  - 2.2 Analog Input
  - 2.3 Front Panel
  - 2.4 Keypads
  - 2.5 LEDs
  - 2.6 Fault Recording
  - 2.7 Event Recording
  - 2.8 Trip Output
  - 2.9 Assignment of the Output Relays
  - 2.10 Potential Input
- 3 Communication
  - 3.1 RS-485 Communication
  - 3.2 USB Front Communication
- 4 Protection Functions
- 5 Display Mode
- 6 Battery Pack
- 7 Setting Ranges
  - 7.1 Protection Settings
  - 7.2 Group Setting
  - 7.3 Cold Load Pickup
  - 7.4 Protection Harmonic Block Settings
  - 7.5 Display Mode setting
  - 7.6 DO Assignment
  - 7.7 DO Reset
  - 7.8 DI Blocking
  - 7.9 Trip Type
  - 7.9 Communication Setting
  - 7.10 Rear port Communication Setting
    - 7.10.1 RS-485 Communication
    - 7.10.2 Front USB Port
  - 7.11 Technical Data
    - 7.11.1 General Data
    - 7.11.2 Measuring Input
    - 7.11.3 Thermal withstand capacity
    - 7.11.4 Accuracy
    - 7.11.5 Measurement Accuracy
    - 7.11.6 Output Contact (Relay Specs)
    - 7.11.7 Certified Type Test
    - 7.11.8 Tripping Characteristics
- 8 Inverse Graphical Representation
- 9 Connection Diagram (CSDPR-V2-200)
- 10 Terminal Description
- 11 Connection Diagram (CSDPR-V2-200-T)
- 12 Terminal Description
- 13 Dimensional Details of Relay
- 14 Ordering Information



## 1. Introduction

In the family of protection relay, CSDPR-V2-200 is numeric multi powered Over-current relay specially designed for ring main units & feeder protection. It combines the following functions in one unit:

- ❖ Relay get energize either from Current, Aux. voltage, front USB or internal battery (whichever is available)
- ❖ O/C, S/C, E/F and E/F High set protection
- ❖ DEFT and Inverse characteristics for O/C and E/F, individually selected for phase and earth fault
- ❖ Unbalance/ Asymmetric protection
- ❖ Potential pulse output for direct triggering the circuit breaker coil. Potential free alarm contacts also available
- ❖ Remote trip & Remote protection block input DI
- ❖ RS-485 Modbus
- ❖ USB port for PC / Laptop interface.
- ❖ Circuit breaker failure protection(50BF)
- ❖ Wide operating ranges of the auxiliary supply voltage (AC/DC)
- ❖ Last 5 Fault and 10 Event record with Time stamp
- ❖ Two set of setting group
- ❖ Cold load pickup protection

## 2. Design

Relay will get energized from any of the following available sources:

- ❖ Aux. supply
- ❖ CT current
- ❖ Internal battery
- ❖ USB port

Relay will operate its trip contacts only when CT current is present or Aux. supply is available, with other power sources, only the relay display/HMI will be available.

In the absence of Aux supply/Battery voltage/USB, LCD will get energized, if CT current is 10% of (single phase or sum of three phases) rated current or above. Trip coil will be operated, if CT current in single phase is at least 20% of rated current or 15% of rated current in three phases. Relay is not powered from Earth CT, so for earth fault protection, phase current is mandatory.

**Note: Battery works when no other supply is present i.e. in the absence of Aux Supply and Current.**

### 2.1 Operation

The CSDPR-V2 is a CT operated protection relay with inverse time and definite time protection characteristics.

CSDPR-V2 works with standard CTs with secondary current and with defined VA burden.

CSDPR-V2 provides following protection functions:

- 3 Phase definite time over current and short circuit protection with variable tripping times (ANSI 50/51)
- 3 Phase over current protection with selectable inverse time characteristics and definite time short circuit current element (ANSI 50/51)
- Definite time and inverse time earth over current protection (ANSI 50N/51N)
- Cold Load Pickup
- Circuit Breaker Protection

### 2.2 Analog Input

The analog input signal of the CT secondary currents as per the terminal detail in Section 9, are fed to the protective device via separate input transformers. The continuously measured current values are galvanically isolated, analog & digitally filtered and finally fed to the analog/digital converter to get the True RMS value.

### 2.3 Front Panel

The front panel of the protective device CSDPR-V2-200 comprises the following operation and indication elements:

- ❖ Big LCD display with Bright white light
- ❖ Keypad for setting of the parameters of the relay
- ❖ 8 LEDs for fault annunciation & 1 LED for Trip Ready & hardware error annunciation

**Note: Relay goes into sleep mode, user has to press  key to see the display.**

## 2.4 Keypads

The front panel keypad consists of six soft-touch keys. These keys are marked as “◀”, “ENTER”, “▶”, “RESET”, “💡” and “ON”. The “RESET” key provides reset function to the relay & “ENTER” act as Enter key for MMI. The keys marked “◀” and “▶” are meant for backward & forward scrolling respectively and also used for decrementing & incrementing the selected parameter value.

“💡” key is used to ON the LCD/to turn ON backlight. When available source (Aux supply, CT current, USB port) is present and no key is pressed for 1 min then LCD gets off.

“🔋” Key is used to ON the LCD when the available source is only battery.

**NOTE:** Under Self powered condition ( i.e. absence of Auxiliary Supply), Backlight will be available in product if current is more than 20% in all phases or 40% in single phase by pressing “💡” Key.

## 2.5 LEDs

There are 09 LEDs on the front panel. Their functions are indicated by the appropriate inscriptions along with them. L1, L2, L3, E, Pickup, Trip, Block & CBFP LEDs are with memory backup & they will maintain the previous status until fault is acknowledged through manual reset. The working is equivalent to a digital flag as unit contains a battery inside.

There is one bi-color LED. “Ready-Healthy / HW Error” LED flashes green when it has sufficient energy to operate the Trip coil. Red is the steady indication of the HW Error.

“BLOCK” LED indicates the protection (selected in DI block menu) is blocked, when Block Digital Input is active. It also indicates Harmonic blocking.

## 2.6 Fault Recording

CSDPR-V2-200 records last 5 Faults. In Fault, it saves following information:

Value at fault	:	L1, L2, L3, E in Amps
Type of fault	:	SC / OC / U0>/CBFP
Time stamp	:	HH:MM:Sec
Date stamp	:	DD:MM:YY
Trip time of fault	:	xxxxxx Sec

## 2.7 Event Recording

CSDPR-V2-200 records last 10 events. It saves following information:

Event Type	:	01
Date	:	DD:MM:YY
Time stamp	:	HH:MM:Sec

\* Event Type = 01 (Power ON)

## 2.8 Trip Output

In presence of Aux supply:

4 Potential Free contacts and 1 Potential O/P (24V/12V@0.2Ws /50msec ON Pulse). Duty cycle will depend upon the strength of available current.

In presence of only adequate CT current:

2 Potential free latch contact and 1 Potential Output (24V/12V@0.2Ws/50msec ON Pulse). Duty cycle will depend upon the strength of available current.

Average 20% of the rated current must required in the phases to trip the breaker.

● **NOTE: Magnetic Trip Flag can be used in parallel to trip Output Contacts Terminal (A6/A7)**

## 2.9 Assignment of the Output Relays

CSDPR has 4 output relays. Two latch relay (Relay-3 & Relay-4) is available in all models. Two extra programmable output relays (Relay-1 & Relay-2) available only with auxiliary supply. Relay reset operation can be configurable in automatic reset or manual reset mode from MMI. In automatic reset mode relay will be reset after the current goes below the pickup level. In manual mode relay will be reset by pressing reset button.

\*Auto/Manual option is not applicable for latch relay.

**NOTE:** Latch Contact ( Relay-3 & Relay4) will get actuate only in presence of fault current. RESET of latch contact is possible under presence of energizing current or Auxiliary supply Or presence of battery.

## 2.10 Potential Input

Two Potential DIs are available for control. Based on model selection these DIs can be used. In TCS model, these two DIs are available for CB open & CB close. In non TCS models, these DIs can be used as Remote Block & Remote Trip.

DI 1: Remote block for 50/50N/51/51N & unbalance protection ( $U_0$ )

DI -2 : Remote trip

DI-1 : Blocking the protection functions

When this input, becomes high it will block the selected protections such as OC/SC/Earth/Earth-high set/  $U_0$ . The selection of protections for blocking is done from MMI. Blocking will remain active till the potential is available on DI terminal.

DI-2: Remote Trip

Irrespective of any pickup or fault user can trip the Circuit breaker, by applying voltage to Remote trip DI.

## 3. Communication

### 3.1 RS-485 Communication

The CSDPR-V2-200 includes an RS-485 communication on rear port This port is available for MODBUS protocol (as per model selection). CSDPR-V2-200 relay has feature to transmit the data such as settings, measurements and faults to the SCADA system. For this communication auxiliary supply is required. A communication failure dose not affects protection function.

### 3.2 USB Front Communication

The front USB communication port is designed for "CSE LIVELINK" for which the front end Software is provided. The S/w has features of retrieving the records and changing the settings

Note: Relay is plug & play on USB port. It automatically get energizes from USB port itself.

## 4. Protection Functions

CSDPR-Vh2-200 offers 50/51/50N/51N/Unbalance/CBFP protections.

Over-current Characteristic: DEFT/VINV/EINV/ NINV3.0/ NINV1.3/LINV/RI/HV-FUSE

### Unbalance Protection(46):

This is provided by the relay tripping in phase unbalance greater than setting % difference in terms of maximum phase current  $U_0$ :  
[[ $(I_{MAX} - I_{MIN}) / I_{MAX}$ ] 100[%]

### Circuit Breaker Failure Protection [CBFP]

The C.B. failure protection is based on supervision of phase current during tripping events. This protective function becomes active only after tripping. The criteria is whether all phase currents are dropped to  $<5\% \times I_N$  within set time of tCBFP. If not, then CB failure is detected and the assigned relay is activated. Annunciation relay for CBFP only manually reset.

### Cold Load Pickup

In CSDPR-V2 unit, this feature is provided to avoid non desired trips, when line de-energized for a period of time and re-energized later, the load exceed the protection setting without the presence of a fault. To avoid such condition, CSDPR-V2 switches from one protection setting group to another setting group for settable time. After expiry of settable time, it will shift back to original group.

## Harmonic based Protection Blocking

To avoid any nuisance tripping, CSDPR-V2 provides harmonic detection & protection blocking feature above 25% and takes 4 cycle to sense the harmonic injection. Relay will hold the tripping for a set time, If harmonic is present with protection pickup. Blocking time & harmonic selection is configurable in the relay.

**Note:** In CSDPR-V2-200 with IEC-103 communication protocol, Harmonic Blocking feature is not present.

## 5. Display Mode

CSDPR-V2-200 works in two modes (AutoOFF/Live)

AutoOFF Mode: LCD gets on by pressing back light key & gets off after 1 minute if no key is pressed.

Live Mode: LCD remains on as long as auxiliary supply / phase current is available.

## 6. Battery Pack

CSDPR-V2-200 comes with internal Li battery pack, which energizes its LCD display to view and set the parameters at the time of initial installation especially when the current/voltage is not available in the RMU. This battery has a life & so it is not meant for long future use. Whenever operator is going at RMU site to fetch the fault record Or to edit/view the settings, we recommend to carry external USB power pack, which will get plugged to front USB of the relay. User can operate the relay using USB power source. We offer rechargeable USB Power Pack as accessory; however user can use any USB power source to energize the relay from USB.

Note: CSDPR-V2-200 will not charge the battery.

## 7. Setting Ranges

### 7.1 Protection Settings

Parameter	Display	Setting range	Step
CT Ratio for primary current display	Ct Rt	1-2500	1
Frequency	Freq	50/60Hz	1
Phase Characteristics	PChr	DEFT, EINV, VINV, NINV3.0, NINV1.3 LINV, RI, HV-FUSE	1
Earth Characteristics	EChr	DEFT, EINV, VINV, NINV3.0, NINV1.3 LINV, RI, HV-FUSE	1
1 <sup>st</sup> Stage phase pickup	I>	0.20 – 2.5 x I <sub>N</sub>	0.01 x I <sub>N</sub>
DEFT Trip time for 1 <sup>st</sup> stage over-current	t>	0.1 –150 s	0.01 s
Inverse TMS for 1 <sup>st</sup> stage phase over-current	ti>	0.01 – 1.500	0.005
2 <sup>nd</sup> Stage phase pickup	I>>	0.5 – 30 x I <sub>N</sub>	0.05 x I <sub>N</sub>
2 <sup>nd</sup> Stage phase trip time	t>>	0.03 – 20 s	0.01 s
Earth fault 1 <sup>st</sup> stage pickup	Ie>	0.05 - 2.5 x I <sub>N</sub>	0.01 x I <sub>N</sub>
DEFT trip time for 1 <sup>st</sup> stage earth fault	te>	0.05 - 150 s	0.01s
Inverse TMS for 1 <sup>st</sup> stage earth fault over-current	tie>	0.01 – 1.500	0.005
2 <sup>nd</sup> Stage earth fault pickup	Ie>>	0.5 – 15 x I <sub>N</sub>	0.05 x I <sub>N</sub>
2 <sup>nd</sup> Stage earth fault trip time	te>>	0.04 – 20 s	0.01s
Phase unbalance pickup	Unb	5 - 80%	1%
Phase unbalance trip time	tUnb	0.1-150 s	0.01 s
Enable CBFP protection	CBFP	YES / NO	-
CBFP time	tCBFP	0.05-2.0 s	0.01 s

### 7.2 Group Setting

Parameter	Display	Setting Range
Group No.	ACT.GRP	Group1 / Group2

### 7.3 Cold Load pickup Setting

Parameter	Display	Setting Range	Step	Unit
Selection of Cold Load Protection	CldLdPr	DISABLE/ENABLE	-	-
Cold Load Active Time	tCdLd	0.1-20	0.01	Sec

### 7.4 Protection Harmonic Block Settings

Parameter	Display	Setting Range	Step	Unit
Selection of Harmonic in Phase	PhHrmnc	2nd, 3rd, 5th & 7th	-	-
Selection of Harmonic in Earth	ErtHrmn	2nd, 3rd, 5th & 7th	-	-
Blocking Time in Phase Harmonic	PTmBk	0.10-20.00	00.01	Sec
Blocking Time in Earth Harmonic	ETmBk	0.10-20.00	00.01	Sec



### 7.5 Display Mode Setting

Parameter	Display	Setting Range	Step	Unit
Display Mode	MOD	AutoOFF/Live	1	-

### 7.6 Relay Assignment

Parameter	Display	Setting Range
Over current	I>	DISABLE/RLY1/RLY2/RLY1RLY2
Short Circuit	I>>	DISABLE/RLY1/RLY2/RLY1RLY2
Earth Low set	Ie>	DISABLE/RLY1/RLY2/RLY1RLY2
Earth High set	Ie>>	DISABLE/RLY1/RLY2/RLY1RLY2
Unbalance	Unb	DISABLE/RLY1/RLY2/RLY1RLY2
Circuit Breaker Failure Protection	CBFP	DISABLE/RLY1/RLY2/RLY1RLY2
Digital Input	Remote	DISABLE/RLY1/RLY2/RLY1RLY2
All Fault	AlFit	DISABLE/RLY1/RLY2/RLY1RLY2

### 7.7 Relay Reset

Parameter	Display	Setting Range
Digital output1	RLY1	Auto/Manual
Digital output2	RLY2	Auto/Manual

### 7.8 DI Blocking

Parameter	Display	Setting Range
Phase Over current Low set	I>	Unblock/Block
Phase Over current High set	I>>	Unblock/Block
Earth Over current Low set	Ie>	Unblock/Block
Earth Over current High set	Ie>>	Unblock/Block
Unbalance	Uo	Unblock/Block

### 7.9 Trip Type

Parameter	Display	Setting Range	Step Size
Mode of tripping	Trip Type	TRIP COIL/LATCH RLY/DUAL	-

### 7.10 Rear Port Communication Setting

#### 7.10.1 (RS-485 Communication)

Parameter	Display	Setting Range
Slave Address	SLV Add	1-32
Baud Rate	BD Rate	9600/19200
Parity	Parity	NONE/EVEN/ODD

#### 7.10.2 Front USB Port

Front Port :	CSE protocol with "CSE LIVELINK" on mini USB cable type A/A
--------------	---

## 7.11 Technical Data

### 7.11.1 General Data

Rated auxiliary voltage UH	Universal:	L: (18V - 60V DC) H: (85V - 260V AC / 110V to 300V DC)
Rated supply for digital input	Normal voltage UN	L: (18V - 60V DC) H: (85V - 260V AC / 110V to 300V DC)
Power consumption of Aux supply	Quiescent approx. 3W	Operating approx. 6W
Dropout pickup ratio	> 95 %	

### 7.11.2 Measuring Input

Rated data	Rated current I <sub>N</sub> (1A)
Frequency:	FN: 50/60 Hz

#### VA Burden: (2.5VA @ Rated Current)

### 7.11.3 Thermal Withstand Capacity

Thermal withstand capacity:	Continuously	2.5A
for I <sub>N</sub> =1A	10s	15A
	1s	80A

### 7.11.4 Accuracy

Tripping times with pre-fault :	DMT : $\pm 5\%$ of the setting value or $\pm 40$ mSec IDMT : Accuracy as per IEC-255-3 (2 x I <sub>s</sub> to 20 I <sub>s</sub> ) For VINV / NINV/RI : $\pm 5\%$ or $\pm 40$ mSec For LINV/EINV/HV-Fuse : $\pm 7.5\%$ or $\pm 60$ mSec
Pickup accuracy:	+5%
Bootup time in self powered mode	$\leq 100$ mSec (with Event Recorder $\leq 300$ mSec)

### 7.11.5 Measurement Accuracy

Quantity	Range	Frequency Range	Accuracy
Current	1.0 - 30 x I <sub>p</sub>	50 / 60 Hz	$\pm 2\%$

### 7.11.6 Output Contact (Relay Specs)

Number of relays	:	4
Relay contacts (RLY: 1, 2) configurable & available only with Auxiliary supply model	:	Relay 1 and 2 are user programmable for I>, I>>, le> and le>>, CBFP, Unbalance (U0>)
Relay contacts: 3, 4 (available in all models)		Latch type of relay common for all protection trip
Max. breaking capacity	:	1250VA / 150W resistive 500VA / 90W inductive
Max. breaking voltage	:	400V AC, 125 VDC
Max. continuous AC current	:	5A



### 7.11.7 Certified Type Test

#### Environmental Conditions

(Recommended ambient Temperature Range)

Operating temperature range:

Continuous withstand: -25°C to +60°C

Limit (Note-1) -25°C to +70°C.

Storage temperature Range: -25°C to +70°C

**Note: The upper limit is permissible not for continuous period.**

#### Mechanical Environment

Vibration Test : IEC 60255-21-1, class 2.

Shock : IEC 60255-21-2, class 1.

S.No	Description of Test	Standard
1	Insulation test	IEC 60255-5
2	Di-electric test	IEC 60255-5
3	5 KV impulse voltage test	IEC 60255-5
4	High freq. interference test severity class 3	IEC 60255-22-1
5	Radio interference suppression test	EN 55011 Cl 5.1.2
6	Radio interference suppression test	EN 55011 Cl 5.22.2
7	Radiated radio frequency electromagnetic field immunity test	IEC 60255-22-3
8	Conductive RF immunity test	ENV 50141
9	Surge immunity	EN 61000.4.5
10	ESD test severity class 3	EN 61000-4-2
11	Fast transient disturbance test	IEC 60255-22-4
12	Power frequency magnetic field immunity test	IEC 61000-4-8

### 7.11.8 Tripping Characteristics (IEC 255-3 or BS 142)

$$\text{Normal Inverse } 3.0 / 1.3 = \frac{0.14/0.06}{(I / I_s)^{2.0} - 1} \quad t_i \text{ [s]}$$

$$\text{Very Inverse} = \frac{13.5}{(I / I_s) - 1} \quad t_i \text{ [s]}$$

$$\text{Extremely Inverse} = \frac{80}{(I / I_s)^2 - 1} \quad t_i \text{ [s]}$$

I: Injected current

I<sub>s</sub>: Pickup set level

t<sub>i</sub>: TMS for inverse characteristic

t: Definite delay in DEFT characteristic



## 8. Inverse Graph Representation

### Inverse Time Characteristics

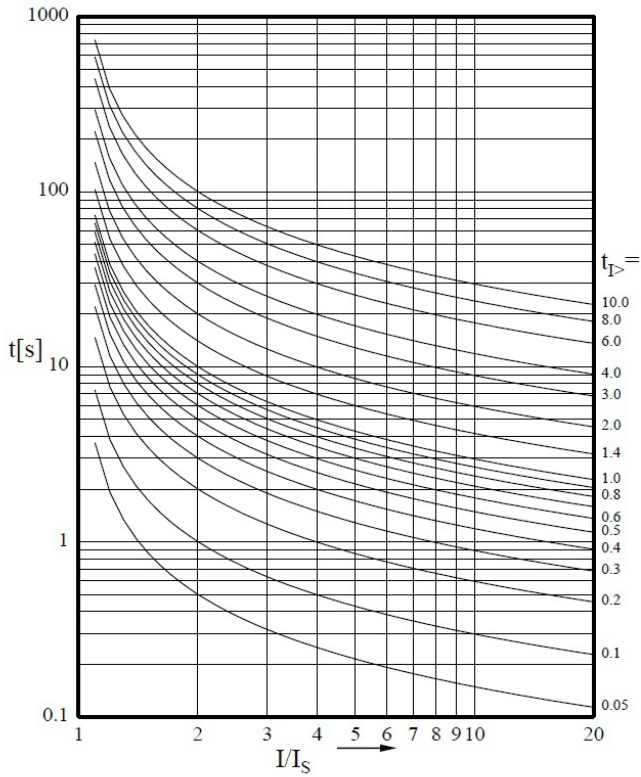

Normal Inverse

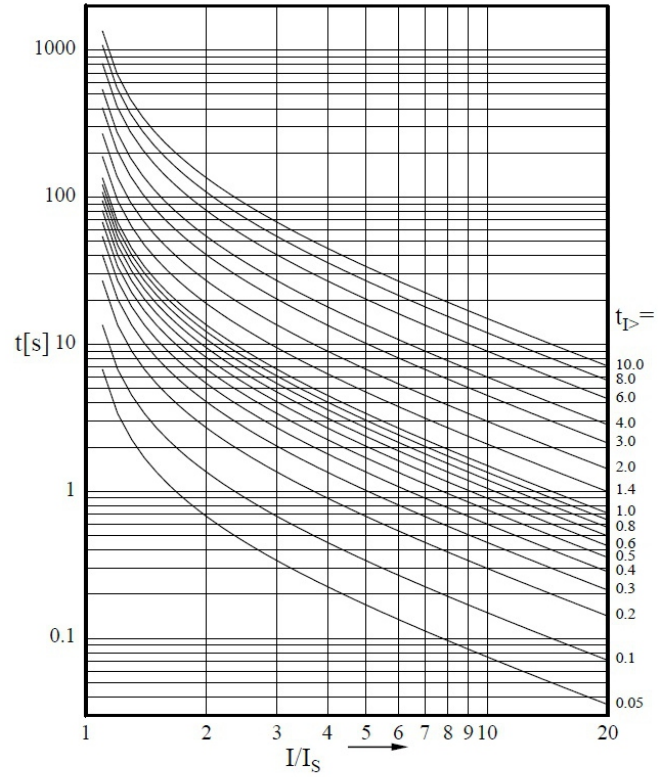

Very Inverse

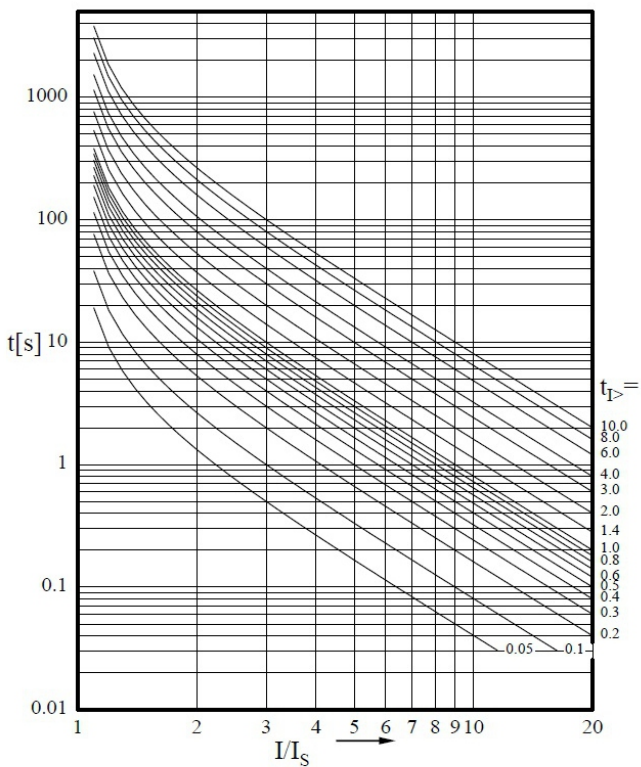

Extremely Inverse

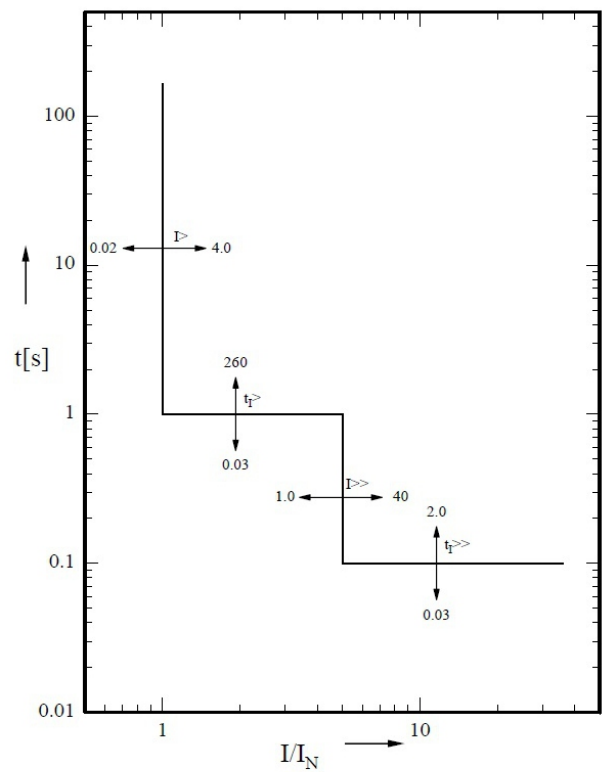

Definite time overcurrent relay

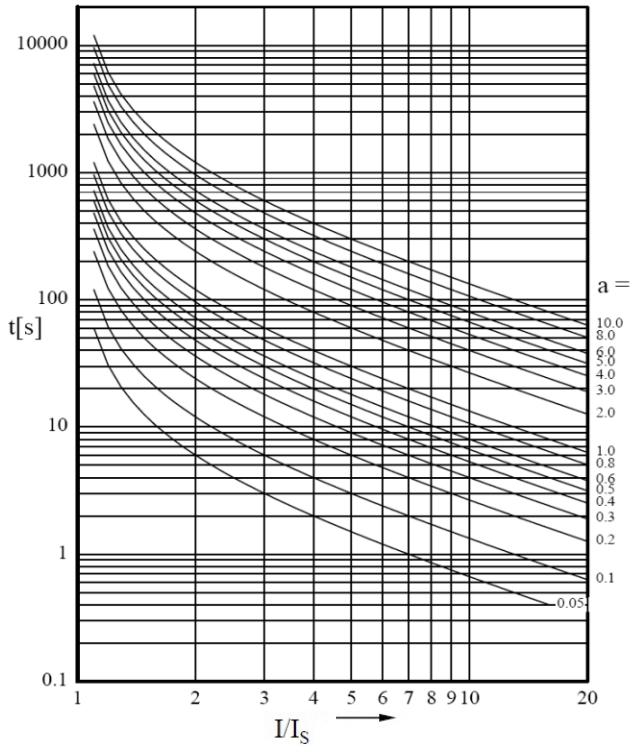

Long time inverse

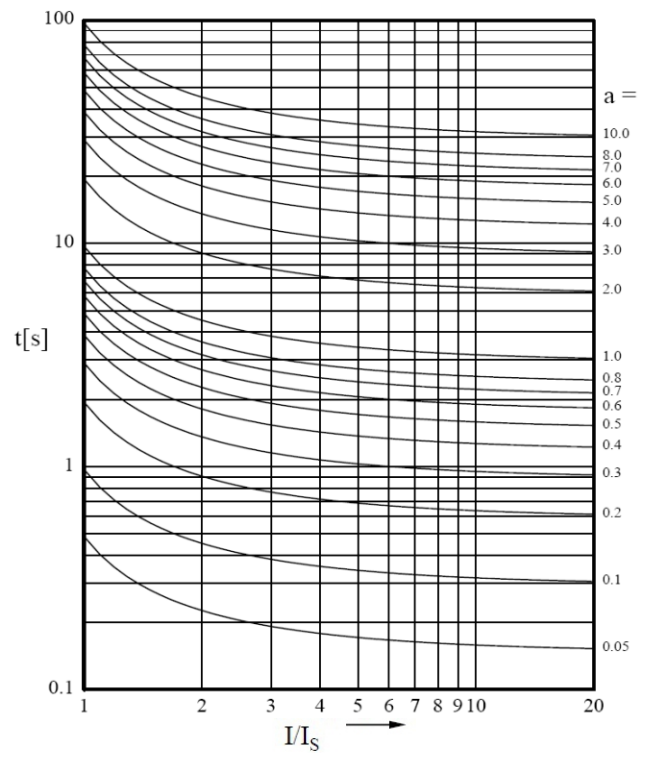

RInverse

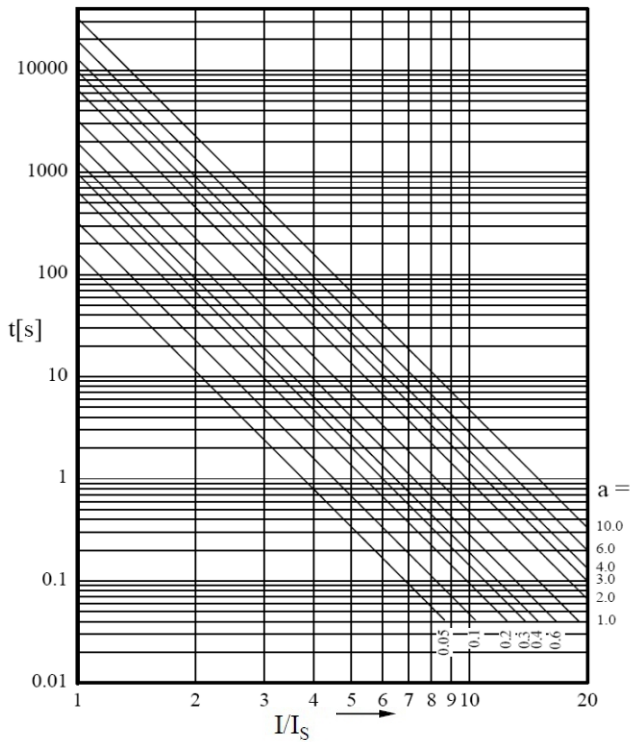

HV-fuse

## 9. Connection Diagram

The following shows the terminals back of CSDPR-V2-200

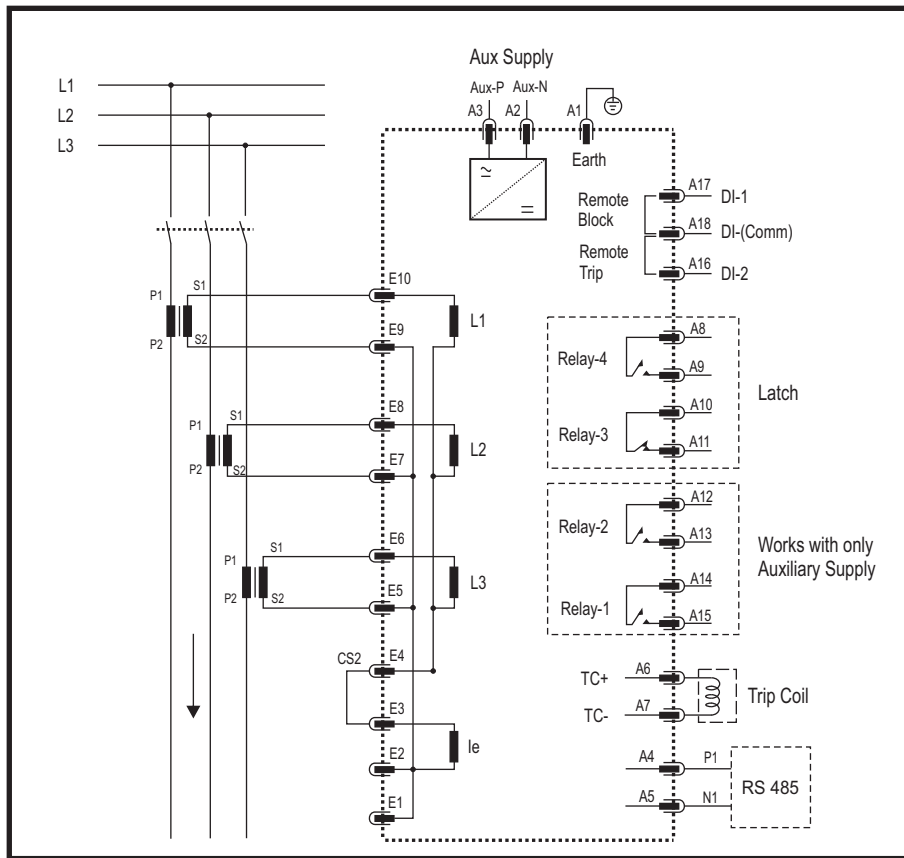

**NOTE:** “While doing the HV test, don’t connect the MHT terminal (A6-A7), as internal capacitor bank could be in charged state & it can harm the circuitry”.

## 10. Terminal Description

The following shows the terminals description of CSDPR-V2-200 model

Terminal Name	Terminal Description
E1	Additional CT common point
E2-E3	CT terminal for Earth current Input
E4	CT interconnection link for different wiring topology
E5-E10	CT terminal for Phase current inputs L1, L2, L3 L1(E10-E9), L2(E8-E7), L3(E6-E5)
A1-A2-A3	Auxiliary supply (Aux-P(A3), Aux-N(A2), Earth(A1)) for CSDPR-V2-200
A4-A5	RS-485 Modbus terminal ((A4)P1-(A5)N1)
A6-A7	Trip coil (TC) pulse output (A6(+)-A7(-))
A8-A9	Relay-4 for all faults with (NO COM) latch contact
A10-A11	Relay-3 for all faults with (NC COM) latch contact
A12-A13	Relay-2 assignable relays with (NO COM) contact (with Aux Supply)
A14-A15	Relay-1 assignable relays with (NO COM) contact (with Aux Supply)
A16	Digital Input (DI-2) for Remote Trip
A17	Digital Input (DI-1) for Remote Block
A18	Digital Input (DI-(Comm.)) common for DI-1 & DI-2

## 11. Connection Diagram

The following shows the terminals back of CSDPR-V2-200-T

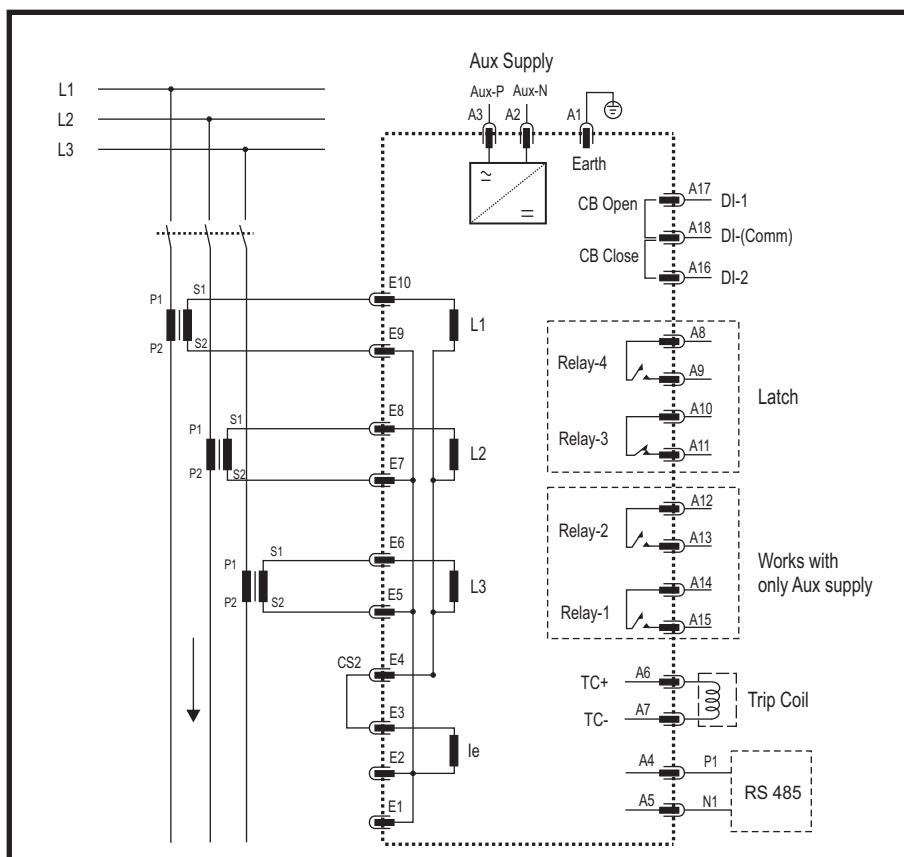

## 12. Terminal Description

The following shows the terminals description of CSDPR-V2-200 model

Terminal Name	Terminal Description
E1	Additional CT common point
E2-E3	CT terminal for Earth current Input
E4	CT interconnection link for different wiring topology
E5-E10	CT terminal for Phase current inputs L1, L2, L3 L1(E10-E9), L2(E8-E7), L3(E6-E5)
A1-A2-A3	Auxiliary supply (Aux-P(A3), Aux-N(A2), Earth(A1)) for CSDPR-V2-200
A4-A5	RS-485 Modbus terminal ((A4)P1-(A5)N1)
A6-A7	Trip coil (TC) pulse output (A6(+)-A7(-))
A8-A9	Relay-4 for all faults with (NO COM) latch contact
A10-A11	Relay-3 for all faults with (NC COM) latch contact
A12-A13	Relay-2 assignable relays with (NO COM) contact (with Aux Supply)
A14-A15	Relay-1 assignable relays with (NO COM) contact (with Aux Supply)
A16	Digital Input (DI-2) for CB Close
A17	Digital Input (DI-1) for CB Open
A18	Digital Input (DI-(Comm.)) common for DI-1 & DI-2

### 13. Dimensional Details of relay with Collar

Panel cutout dimension : WxH = 112.0x145.0mm

Front View

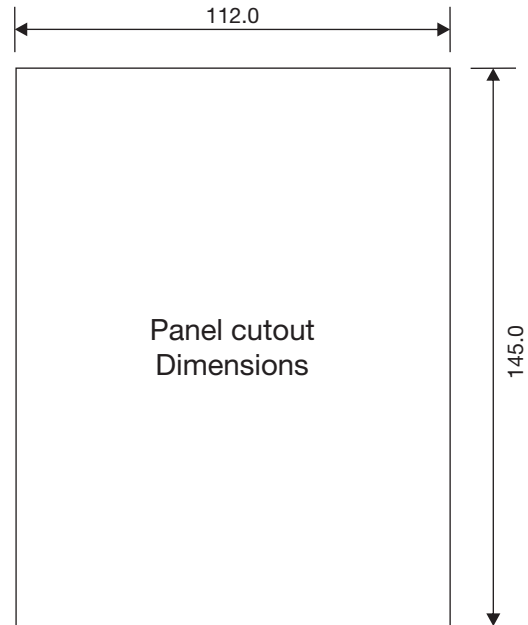
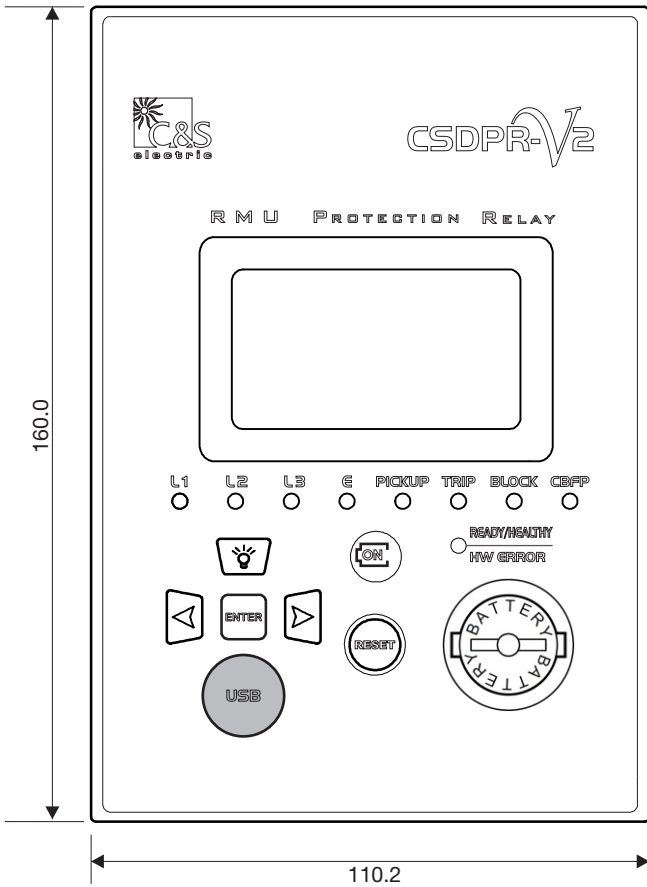

Side View

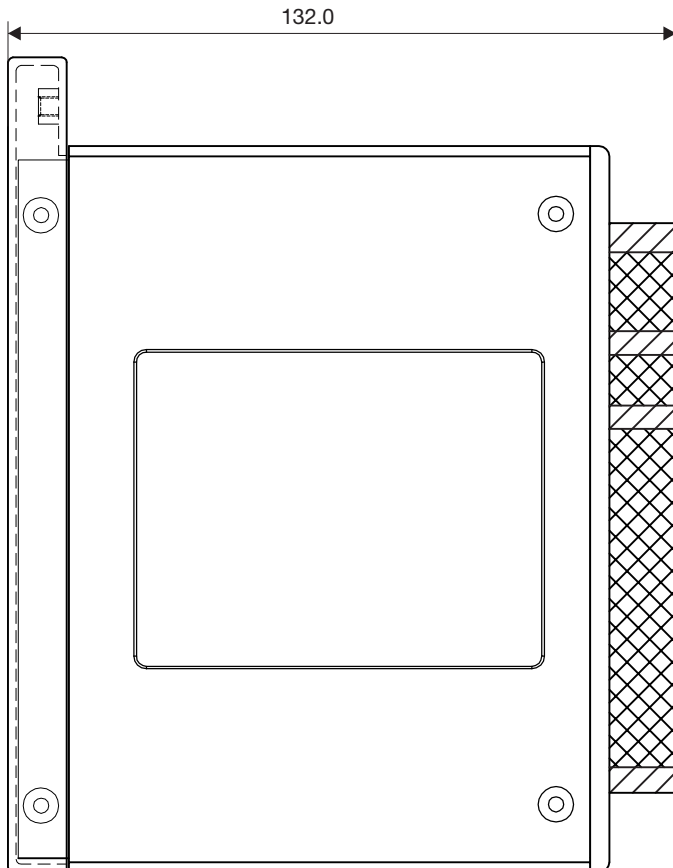



## 14. Ordering Information

MODEL NO.: **CSDPR-V2** - **X** - **X** - **X** - **X** - **X** - **X**

Model No.  
200

D: Dual Powered with Communication

Auxiliary Supply Range  
L : 18V -60V DC  
H : 85V-260V AC / 110V-300V DC

Mounting Arrangement  
P : Extended Collar without Dust cover

Trip Circuit Supervision  
- : Without TCS  
T : With TCS

Communication  
M : Modbus Protocol  
I : IEC-60870-5-103

S.No.	Rev.No.	Details	Date
01	05	Terminal description changed and note inserted on page 12.	05.05.14
02	06	Measurement Accuracy table inserted	24.05.14
03	07	Conn Diagram changed	28.05.14
04	08	"Trip LED" renamed as "Ready/Healthy" and modified its corresponding data.	05.06.14
05	09	Change in "Design" & "Trip output".	26.06.14
06	10	Change in "Front Panel" & Battery Pack.	23.07.14
07	11	In Design heading, modification in "Note"	26.07.14
08	12	Inclusion of Conn. Diagram((CSDPR-V2-200-T), TCS option in Ordering Information & change 2.10 "Potential Input"	31.07.14
09	13	Inclusion of VA Burden at 7.11.2 Measuring Input Heading	20.08.14
10	14	<b>NOTE</b> included in the clause 2.4 'Keypads' & and clause 2.9 'Assignment of output Relays'.	17.09.14
11	15	<b>NOTE</b> included in the clause 9 'Connection Diagram'.	21.01.15
12	16	Inclusion of NOTE for Harmonic based protection Blocking.	20.04.15

For further information, please contact:

**C&S Electric Ltd.**  
**(Protection & Measurement Devices)**

C-60, Wing-A, Phase-II, Noida -201 305, District Gautam Budh Nagar (U.P) INDIA  
 Phone : +91 120-305 7700 / 01, Fax: +91 120-305 7704  
 E-mail: [marketing.cspc@cselectric.co.in](mailto:marketing.cspc@cselectric.co.in)

Issue Date : 12.12.13  
 Rev. No : 16  
 Rev. Date : 20.04.15

**Branch office**

Branch	Phone	Fax	E-mail
Ahmedabad:	+91 79 30074534/35/36	+91 79 30074519	<a href="mailto:cspc.ahmedabad@cselectric.co.in">cspc.ahmedabad@cselectric.co.in</a>
Bangalore:	+91 80 3057 0372/73, 3057 0347	+91 2558 4839	<a href="mailto:cspc.bangalore@cselectric.co.in">cspc.bangalore@cselectric.co.in</a>
Bhubaneswar:	+91 674 2507265	+91 674 2507265	<a href="mailto:cspc.bhubaneswar@cselectric.co.in">cspc.bhubaneswar@cselectric.co.in</a>
Chennai:	+91 44 3918 0531-35	+91 44 39180514	<a href="mailto:cspc.chennai@cselectric.co.in">cspc.chennai@cselectric.co.in</a>
Cochin:	+91 0484 3071717	+91 0484 3071716	<a href="mailto:cspc.cochin@cselectric.co.in">cspc.cochin@cselectric.co.in</a>
Delhi:	+91 11 30838822-25	+91 11 30838826	<a href="mailto:cspc.delhi@cselectric.co.in">cspc.delhi@cselectric.co.in</a>
Hyderabad:	+91 40 3918 2496/97	+91 40 3910 3631	<a href="mailto:cspc.hyderabad@cselectric.co.in">cspc.hyderabad@cselectric.co.in</a>
Kolkata:	+91 33 22275850/51	+91 33 2227 5849	<a href="mailto:cspc.kolkata@cselectric.co.in">cspc.kolkata@cselectric.co.in</a>
Mumbai:	+91 22 30487146/47/48	+91 22 2412 6631	<a href="mailto:cspc.mumbai@cselectric.co.in">cspc.mumbai@cselectric.co.in</a>
Pune:	+91 20 30283244/45	+91 20 30283244	<a href="mailto:cspc.pune@cselectric.co.in">cspc.pune@cselectric.co.in</a>