

We touch your **electricity** everyday!

CSDPR-V2-200-A-P

Intelligent measuring & protection device



Catalogue

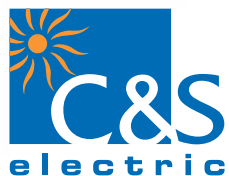

Multi Powered Current Protection Relay

Index

- 1 Introduction
- 2 Design
 - 2.1 Operation
 - 2.2 Analog Input
 - 2.3 Front Panel
 - 2.4 Keypads
 - 2.5 LEDs
 - 2.6 Fault Recording
 - 2.7 Event Recording
 - 2.8 Trip Output
 - 2.9 Assignment of the Output Relays
 - 2.10 Potential Input
- 3 Communication
 - 3.1 RS-485 Communication
 - 3.2 USB Front Communication
- 4 Protection Functions
- 5 Setting Ranges
 - 5.1 Protection Settings
 - 5.2 Group Setting
 - 5.3 Cold Load Pickup
 - 5.4 Protection Harmonic Block Settings
 - 5.5 Display Mode Setting
 - 5.6 Relay Assignment
 - 5.7 Relay Reset
 - 5.8 DI Blocking
 - 5.9 Rear Port Communication Setting
 - 5.9.1 RS-485 Communication
 - 5.9.2 Front USB Port
 - 5.10 Technical Data
 - 5.10.1 General Data
 - 5.10.2 Measuring Input
 - 5.10.3 Thermal withstand capacity
 - 5.10.4 Accuracy
 - 5.10.5 Measurement Accuracy
 - 5.10.6 Output Contact (Relay Specs)
 - 5.10.7 Certified Type Test
 - 5.10.8 Tripping Characteristics
- 6 Inverse Graphical Representation
- 7 Connection Diagram (CSDPR-V2-200)
- 8 Terminal Description
- 9 Dimensional Details of Relay
- 10 Ordering Information



1. Introduction

In the family of protection relay, CSDPR-V2-200 is numeric Over-current relay specially designed for ring main units & feeder protection. It combines the following functions in one unit:

- ❖ O/C, S/C, E/F and E/F High set protection
- ❖ DEFT and Inverse characteristics for O/C and E/F, individually selected for Phase and Earth fault
- ❖ Unbalance/ Asymmetric protection
- ❖ Remote Trip & Remote Protection Block Input DI
- ❖ RS-485 Modbus
- ❖ USB port for PC / Laptop Interface.
- ❖ Circuit Breaker Failure Protection (50BF)
- ❖ Wide Operating ranges of the auxiliary supply voltage (AC/DC)
- ❖ Last 5 Fault and 10 Event record with Time stamp
- ❖ Two set of setting group
- ❖ Cold Load Pickup protection

2. Design

2.1 Operation

The CSDPR-V2 is a over-current protection relay with inverse time and definite time protection characteristics.

CSDPR-V2 provides following protection functions:

- 3 Phase definite time over current and short circuit protection with variable tripping times (ANSI 50/51)
- 3 Phase over current protection with selectable inverse time characteristics and definite time short circuit current element (ANSI 50/51)
- Definite time and inverse time earth over current protection (ANSI 50N/51N)
- Cold Load Pickup
- Circuit Breaker Protection

2.2 Analog Input

The analog input signal of the CT secondary currents as per the terminal detail in Section 8, are fed to the protective device via separate input transformers. The continuously measured current values are galvanically isolated, analog & digitally filtered and finally fed to the analog/digital converter to get the True RMS value.

2.3 Front Panel

The front panel of the protective device CSDPR-V2-200 comprises the following operation and indication elements:

- ❖ Big LCD display with Bright white light
- ❖ Keypad for setting of the parameters of the relay
- ❖ 8 LEDs for fault annunciation & 1 LED for Trip Ready & hardware error annunciation

Note: Relay goes into sleep mode, user has to press  key to see the display.

2.4 Keypads

The front panel keypad consists of five soft-touch keys. These keys are marked as “◀”, “ENTER”, “▶”, “RESET”, “💡” and “ON”. The “RESET” key provides reset function to the relay & “ENTER” act as Enter key for MMI. The keys marked “◀” and “▶” are meant for backward & forward scrolling respectively and also used for decrementing & incrementing the selected parameter value.

“💡” key is used to ON the LCD.

2.5 LEDs

There are eight LEDs on the front panel. Their functions are indicated by the appropriate inscriptions along with them. L1, L2, L3, E, Trip, Block & CBFP LEDs are with memory backup & they will maintain the previous status until fault is acknowledged through manual reset. Only the latest fault status will be shown on the LED. If the previous fault of LED is not cleared, the new fault will override on the previous fault & LED will show the latest fault only.

“BLOCK” LED indicates the protection (selected in DI block menu) is blocked, when Block Digital Input is active. It also indicates Harmonic blocking.

2.6 Fault Recording

CSDPR-V2-200 records last 5 Faults. In Fault, it saves following information:

Value at fault	:	L1, L2, L3, E in Amps
Type of fault	:	SC / OC / U0>/CBFP
Time stamp	:	HH:MM:Sec
Date stamp	:	DD:MM:YY
Trip time of fault	:	xxxxxx Sec

2.7 Event Recording

CSDPR-V2-200 records last 10 events. It saves following information:

Event Type	:	01
Date	:	DD:MM:YY
Time stamp	:	HH:MM:Sec

* Event Type = 01 (Power ON)

2.8 Trip Output

Four Potential Free contacts are available for Fault assignment / Control scheme

2.9 Assignment of the Output Relays

CSDPR has 4 output relays. Two latch relays are fixed (Relay-3 & Relay-4). Relay-1 & Relay-2 are programmable relays. Relay reset operation can be configurable in automatic reset or manual reset mode from MMI. In automatic reset mode relay will be reset after the current goes below the pickup level. In manual mode relay will be reset by pressing reset button.

*Auto/Manual option is not applicable for latch relay.

2.10 Potential Input

Two Potential DIs are available for control. These DIs can be used as Remote Block & Remote Trip.

DI 1 : Remote block for 50/50N/51/51N & unbalance protection (U0>)

DI -2 : Remote trip

DI-1 : Blocking the protection functions

When this input, becomes high it will block the selected protections such as OC/SC/Earth/Earth-high set/ U0>. The selection of protections for blocking is done from MMI. Blocking will remain active till the potential is available on DI terminal.

DI-2: Remote Trip

Irrespective of any pickup or fault user can trip the Circuit breaker, by applying voltage to Remote trip DI.

Note: No Battery Backup is available in this Model. This model is purely a Auxiliary powered.

3. Communication

3.1 RS-485 Communication

The CSDPR-V2-200 includes an RS-485 communication on rear port. This port is available for MODBUS protocol (as per model selection). CSDPR-V2-200 relay has feature to transmit the data such as settings, measurements and faults to the SCADA system. A communication failure does not affect protection function.

3.2 USB Front Communication

The front USB communication port is designed for “CSE LIVELINK” for which the front end Software is provided. The S/w has features of retrieving the records and changing the settings.

Note: Relay is plug & play on USB port. It automatically gets energized from USB port itself.

4. Protection Functions

CSDPR-V2-200 offers 50/51/50N/51N/Unbalance/CBFP protections.

Over-current Characteristic: DEFT/VINV/EINV/ NINV3.0/ NINV1.3/LINV/RI/HV-FUSE

Unbalance Protection(46):

This is provided by the relay tripping in phase unbalance greater than setting % difference in terms of maximum phase current U_0 :
 $[(I_{MAX} - I_{MIN}) / I_{MAX}] \times 100[\%]$

Circuit Breaker Failure Protection [CBFP]

The C.B. failure protection is based on supervision of phase current during tripping events. This protective function becomes active only after tripping. The criteria is whether all phase currents are dropped to $<5\% \times I_N$ within set time of t_{CBFP} . If not, then CB failure is detected and the assigned relay is activated. Annunciation relay for CBFP only manually reset.

Cold Load Pickup

In CSDPR-V2 unit, this feature is provided to avoid non desired trips, when line de-energized for a period of time and re-energized later, the load exceeds the protection setting without the presence of a fault. To avoid such condition, CSDPR-V2 switches from one protection setting group to another setting group for settable time. After expiry of settable time, it will shift back to original group.

Harmonic based Protection Blocking

To avoid any nuisance tripping, CSDPR-V2 provides harmonic detection & protection blocking feature above 25% and takes 4 cycle to sense the harmonic injection. Relay will hold the tripping for a set time, if harmonic is present with protection pickup. Blocking time & harmonic selection is configurable in the relay.

5. Setting Ranges

5.1 Protection Settings

Parameter	Display	Setting range	Step
CT Ratio for primary current display	Ct Rt	1-2500	1
Frequency	Freq	50/60Hz	1
Phase Characteristics	PChr	DEFT, EINV, VINV, NINV3.0, NINV1.3 LINV, RI, HV-FUSE	1
Earth Characteristics	EChr	DEFT, EINV, VINV, NINV3.0, NINV1.3 LINV, RI, HV-FUSE	1
1 st Stage phase pickup	I>	0.20 – 2.5 x I _N	0.01 x I _N
DEFT Trip time for 1 st stage over-current	t>	0.1 – 150 s	0.01 s
Inverse TMS for 1 st stage phase over-current	ti>	0.01 – 1.500	0.005
2 nd Stage phase pickup	I>>	0.5 – 30 x I _N	0.05 x I _N
2 nd Stage phase trip time	t>>	0.03 – 20 s	0.01 s
Earth fault 1 st stage pickup	Ie>	0.05 - 2.5 x I _N	0.01 x I _N
DEFT trip time for 1 st stage earth fault	te>	0.05 - 150 s	0.01s
Inverse TMS for 1 st stage earth fault over-current	tie>	0.01 – 1.500	0.005
2 nd Stage earth fault pickup	Ie>>	0.5 – 15 x I _N	0.05 x I _N
2 nd Stage earth fault trip time	te>>	0.04 – 20 s	0.01s
Phase unbalance pickup	Unb	5 - 80%	1%
Phase unbalance trip time	tUnb	0.1-150 s	0.01 s
Enable CBFP protection	CBFP	YES / NO	-
CBFP time	tCBFP	0.05-2.0 s	0.01 s

5.2 Group Setting

Parameter	Display	Setting Range
Group No.	ACT.GRP	Group1 / Group2

5.3 Cold Load pickup Setting

Parameter	Display	Setting Range	Step	Unit
Selection of Cold Load Protection	CldLdPr	DISABLE/ENABLE	-	-
Cold Load Active Time	tCdLd	0.1-20	0.01	Sec

5.4 Protection Harmonic Block Settings

Parameter	Display	Setting Range	Step	Unit
Selection of Harmonic in Phase	PhHrmnc	2nd, 3rd, 5th & 7th	-	-
Selection of Harmonic in Earth	ErtHrmn	2nd, 3rd, 5th & 7th	-	-
Blocking Time in Phase Harmonic	PTmBk	0.10-20.00	00.01	Sec
Blocking Time in Earth Harmonic	ETmBk	0.10-20.00	00.01	Sec

5.5 Display Mode Setting

Parameter	Display	Setting Range	Step	Unit
Display Mode	MOD	AutoOFF/Live	1	-

5.6 Relay Assignment

Parameter	Display	Setting Range
Over current	I>	DISABLE/RLY1/RLY2/RLY1RLY2
Short Circuit	I>>	DISABLE/RLY1/RLY2/RLY1RLY2
Earth Low set	Ie>	DISABLE/RLY1/RLY2/RLY1RLY2
Earth High set	Ie>>	DISABLE/RLY1/RLY2/RLY1RLY2
Unbalance	Unb	DISABLE/RLY1/RLY2/RLY1RLY2
Circuit Breaker Failure Protection	CBFP	DISABLE/RLY1/RLY2/RLY1RLY2
Digital Input	Remote	DISABLE/RLY1/RLY2/RLY1RLY2
All Fault	AIFIt	DISABLE/RLY1/RLY2/RLY1RLY2

5.7 Relay Reset

Parameter	Display	Setting Range
Digital output1	RLY1	Auto/Manual
Digital output2	RLY2	Auto/Manual

5.8 DI Blocking

Parameter	Display	Setting Range
Phase Over current Low set	I>	Unblock/Block
Phase Over current High set	I>>	Unblock/Block
Earth Over current Low set	Ie>	Unblock/Block
Earth Over current High set	Ie>>	Unblock/Block
Unbalance	Uo	Unblock/Block

5.9 Rear Port Communication Setting

5.9.1 (RS-485 Communication)

Parameter	Display	Setting Range
Slave Address	SLV Add	1-32
Baud Rate	BD Rate	9600/19200
Parity	Parity	NONE/EVEN/ODD

5.9.2 Front USB Port

Front Port : CSE protocol with "CSE LIVELINK" on mini USB cable type A/A

5.10 Technical Data

5.10.1 General Data

Rated auxiliary voltage UH	Universal:	L: (18V - 60V DC)
		H: (85V - 260V AC / 110V to 300V DC)
Rated supply for digital input	Normal voltage UN	L: (18V - 60V DC)
		H: (85V - 260V AC / 110V to 300V DC)
Power consumption of Aux supply	Quiescent approx. 3W	Operating approx. 6W
Dropout pickup ratio	> 95 %	

5.10.2 Measuring Input

Rated data	Rated current I _N (1A)
Frequency:	FN: 50/60 Hz

VA Burden: (Rated Current @0.1VA)

5.10.3 Thermal Withstand Capacity

Thermal withstand capacity:	Continuously	2.5A
for I _n =1A	10s	15A
	1s	80A

5.10.4 Accuracy

Tripping times with prefault :	DMT : $\pm 5\%$ of the setting value or ± 40 mSec IDMT : Accuracy as per IEC-255-3 (2 x I _s to 20 I _s) For VINV / NINV/RI : $\pm 5\%$ or ± 40 mSec For LINV/EINV/HV-Fuse : $\pm 7.5\%$ or ± 60 mSec +5%
Pickup accuracy:	≤ 100 mSec
Bootup time in self powered mode	(with Event Recorder ≤ 300 mSec)

5.10.5 Measurement Accuracy

Quantity	Range	Frequency Range	Accuracy
Current	1.0 - 30 xI _p	50 / 60 Hz	$\pm 2\%$

5.10.6 Output Contact (Relay Specs)

Number of relays	:	4
Relay contacts (RLY: 1, 2) configurable & available only with Auxiliary supply model	:	Relay 1 and 2 are user programmable for I>, I>>, Ie> and Ie>>, CBFP, Unbalance (U ₀ >)
Relay contacts: 3, 4 (available in all models)		Latch type of relay common for all protection trip
Max. breaking capacity	:	1250VA / 150W resistive 500VA / 90W inductive
Max. breaking voltage	:	400V AC, 125 VDC
Max. continuous AC current	:	5A

5.10.7 Certified Type Test

Environmental Conditions

(Recommended ambient Temperature Range)

Operating temperature range:

Continuous withstand: -25°C to +60°C

Limit (Note-1) -25°C to +70°C.

Storage temperature Range: -25°C to +70°C

Note: The upper limit is permissible not for continuous period.

Mechanical Environment

Vibration Test : IEC 60255-21-1, class 2.

Shock : IEC 60255-21-2, class 1.

S.No	Description of Test	Standard
1	Insulation test	IEC 60255-5
2	Di-electric test	IEC 60255-5
3	5 KV impulse voltage test	IEC 60255-5
4	High freq. interference test severity class 3	IEC 60255-22-1
5	Radio interference suppression test	EN 55011 CI 5.1.2
6	Radio interference suppression test	EN 55011 CI 5.22.2
7	Radiated radio frequency electromagnetic field immunity test	IEC 60255-22-3
8	Conductive RF immunity test	ENV 50141
9	Surge immunity	EN 61000.4.5
10	ESD test severity class 3	EN 61000-4-2
11	Fast transient disturbance test	IEC 60255-22-4
12	Power frequency magnetic field immunity test	IEC 61000-4-8

5.10.8 Tripping Characteristics (IEC 255-3 or BS 142)

$$\text{Normal Inverse } 3.0 / 1.3 = \frac{0.14/0.06}{(I / I_s)^{0.02} - 1} \quad t_i \text{ [s]}$$

$$\text{Very Inverse} = \frac{13.5}{(I / I_s) - 1} \quad t_i \text{ [s]}$$

$$\text{Extremely Inverse} = \frac{80}{(I / I_s)^2 - 1} \quad t_i \text{ [s]}$$

I: Injected current

I_s: Pickup set level

t_i: TMS for inverse characteristic

t: Definite delay in DEFT characteristic



!!! CAUTION !!!

O/C, S/C, E and EH protections are available with DISABLE option in HMI.

6. Inverse Graph Representation

Inverse Time Characteristics

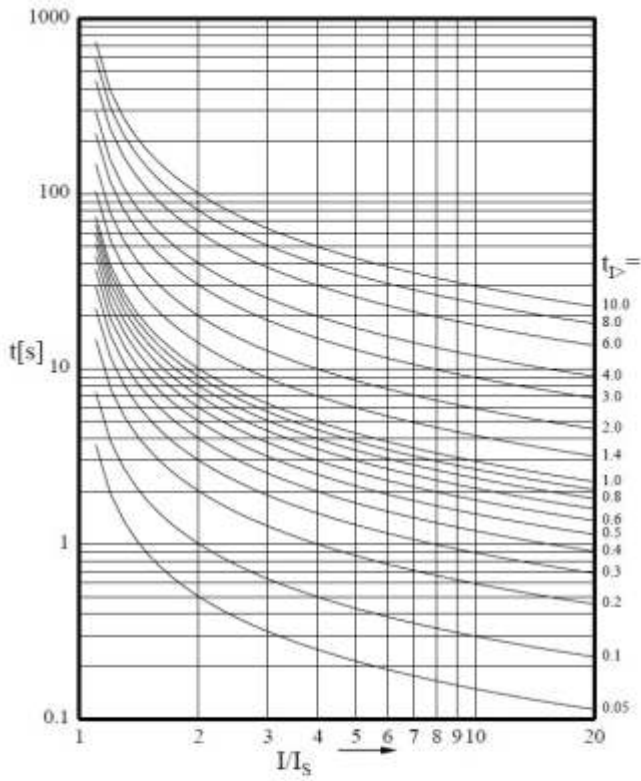

Normal Inverse

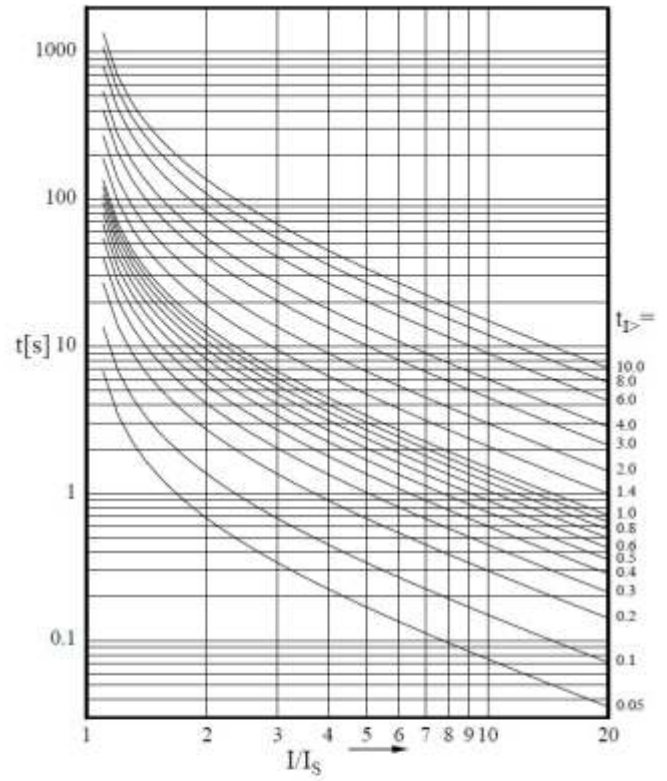

Very Inverse

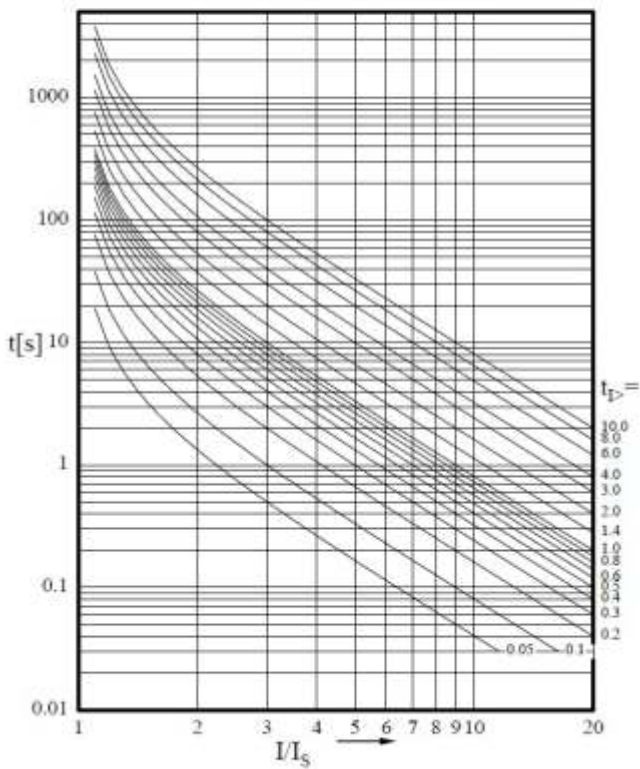

Extremely Inverse

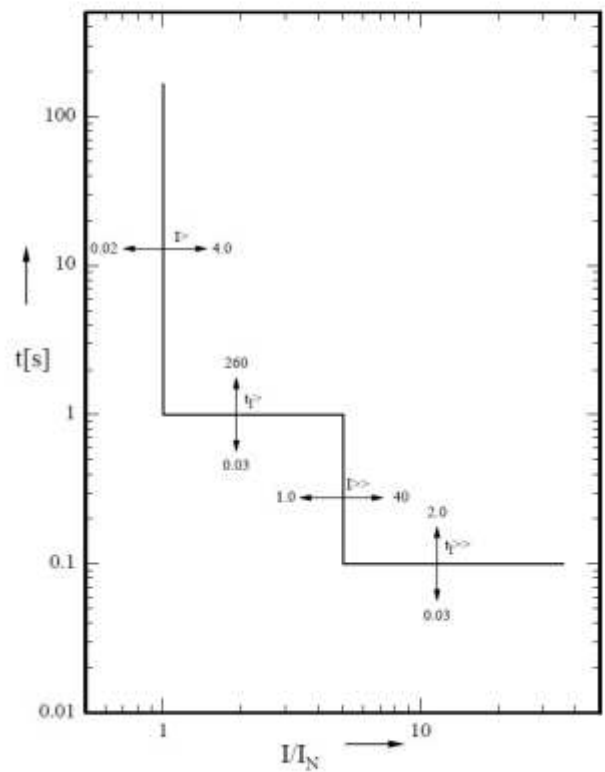

Definite time overcurrent relay

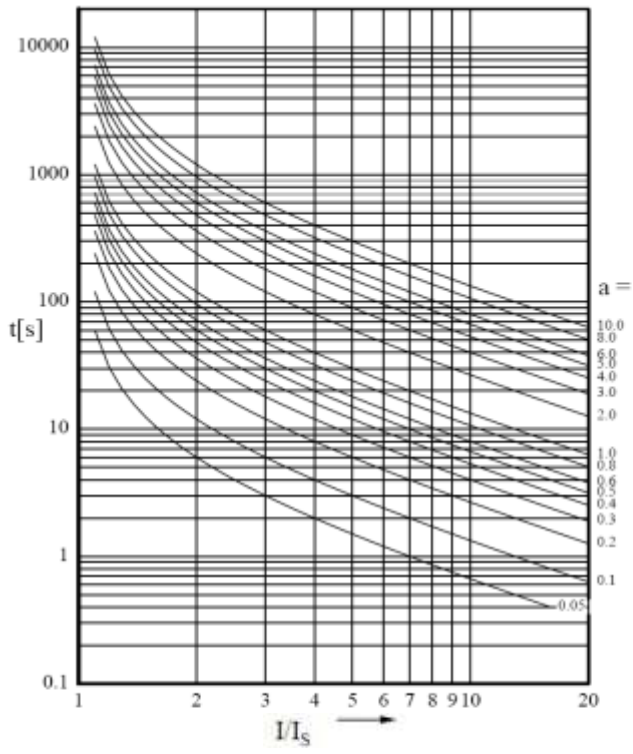

Long time inverse

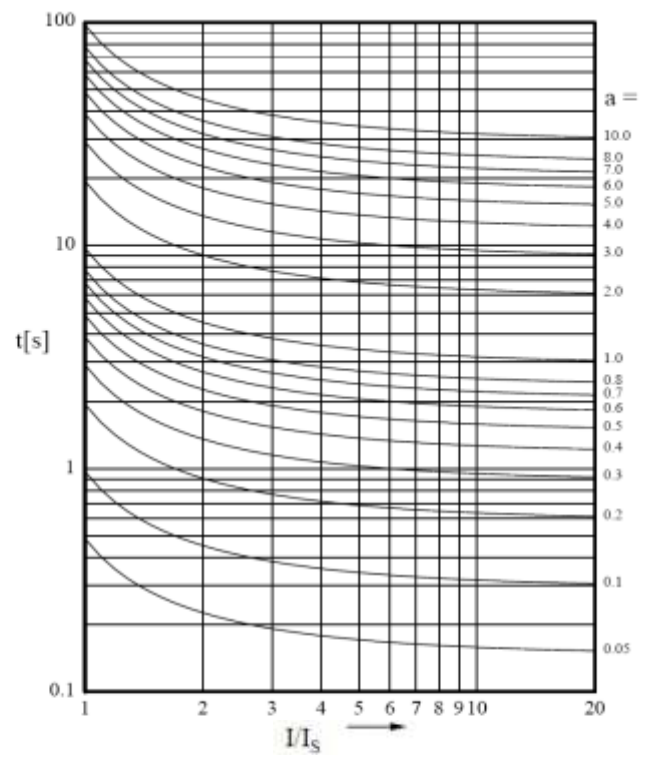

RHinverse

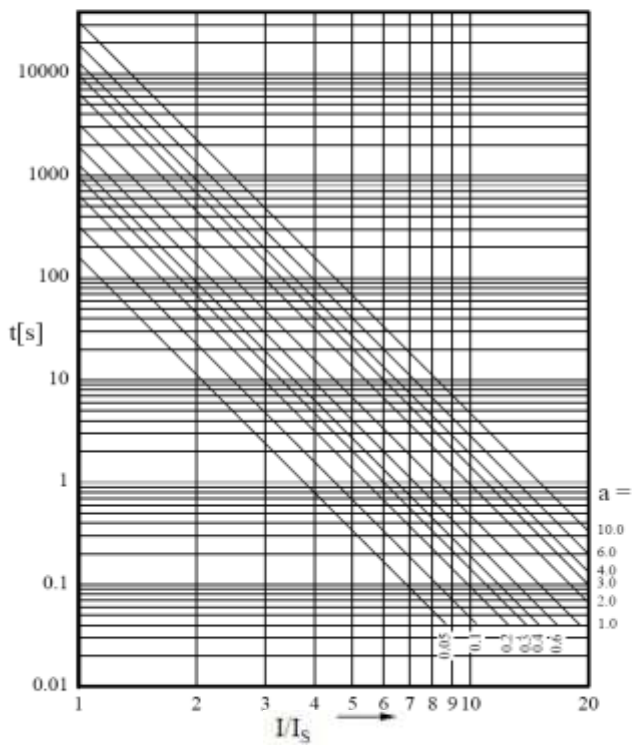

HV-fuse

7. Connection Diagram

The following shows the terminals back of CSDPR-V2-200

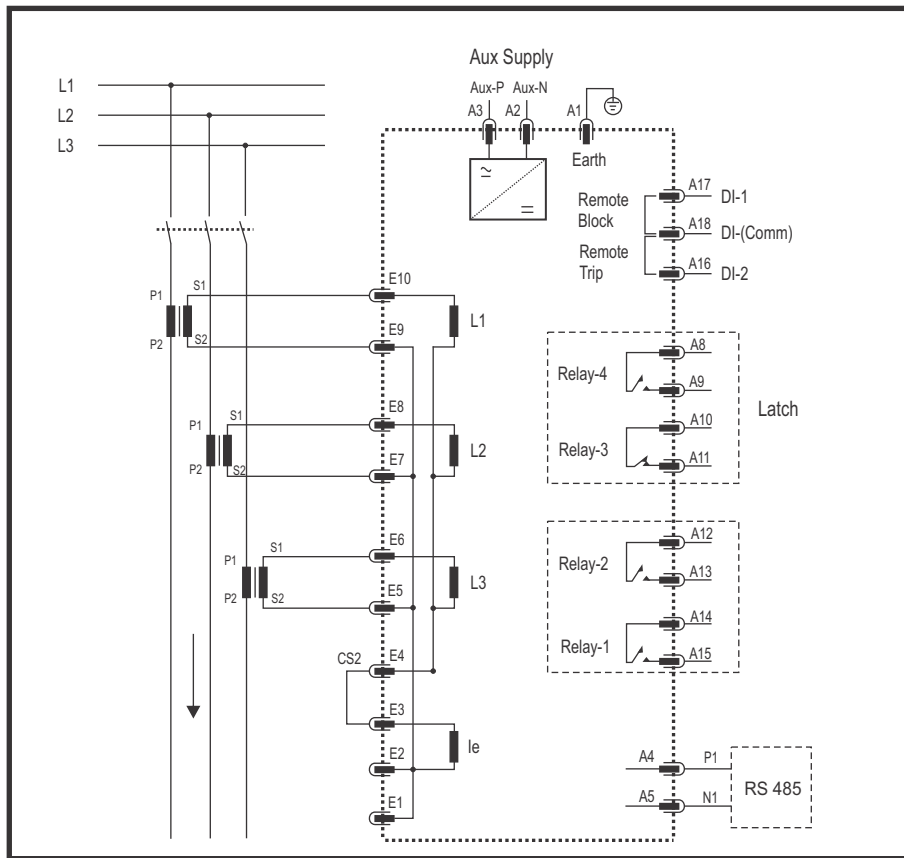

8. Terminal Description

The following shows the terminals description of CSDPR-V2-200 model

Terminal Name	Terminal Description
E1	Additional CT common point
E2-E3	CT terminal for Earth current Input
E4	CT interconnection link for different wiring topology
E5-E10	CT terminal for Phase current inputs L1, L2, L3 L1(E10-E9), L2(E8-E7), L3(E6-E5)
A1-A2-A3	Auxiliary supply (Aux-P(A3), Aux-N(A2), Earth(A1)) for CSDPR-V2-200
A4-A5	RS-485 Modbus terminal ((A4)P1-(A5)N1)
A6-A7	---
A8-A9	Relay-4 for all faults with (NO COM) latch contact
A10-A11	Relay-3 for all faults with (NC COM) latch contact
A12-A13	Relay-2 assignable relays with (NO COM) contact
A14-A15	Relay-1 assignable relays with (NO COM) contact
A16	Digital Input (DI-2) for Remote Trip
A17	Digital Input (DI-1) for Remote Close
A18	Digital Input (DI-(Comm.)) common for DI-1 & DI-2

9. Dimensional Details of relay with Collar

Panel cutout dimension : WxH = 112.0x145.0mm

Front View

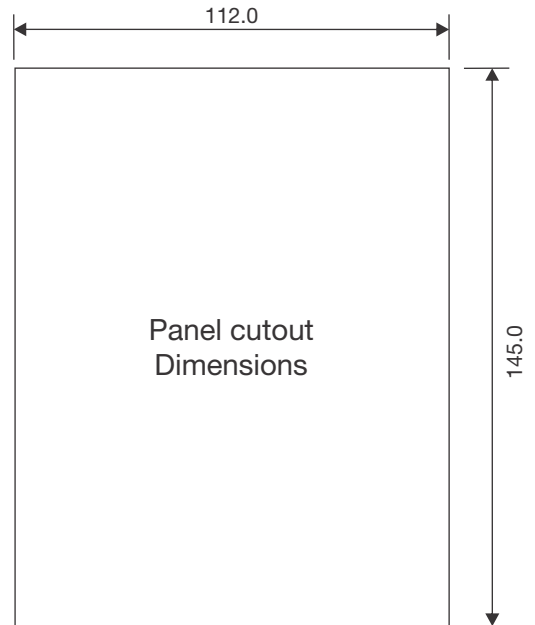
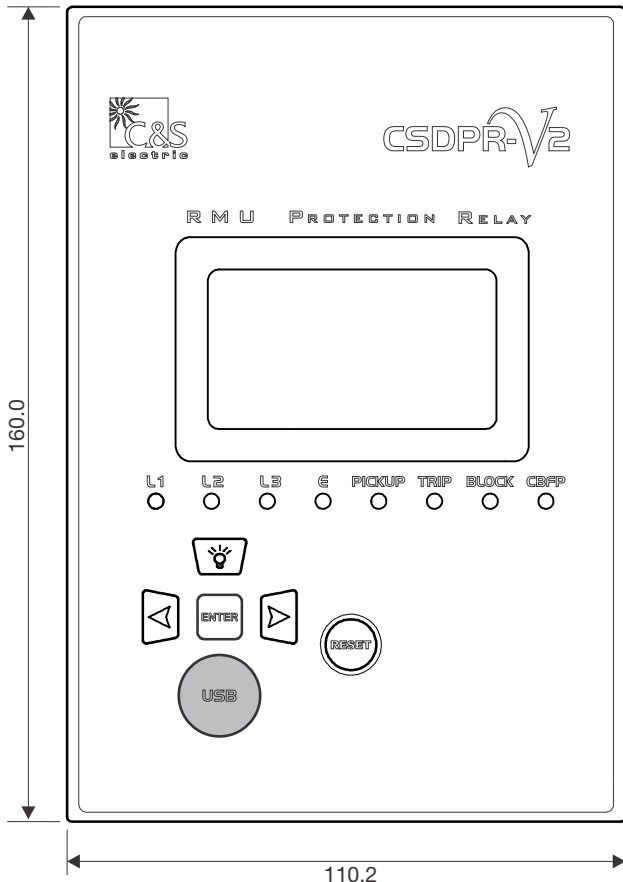

Side View

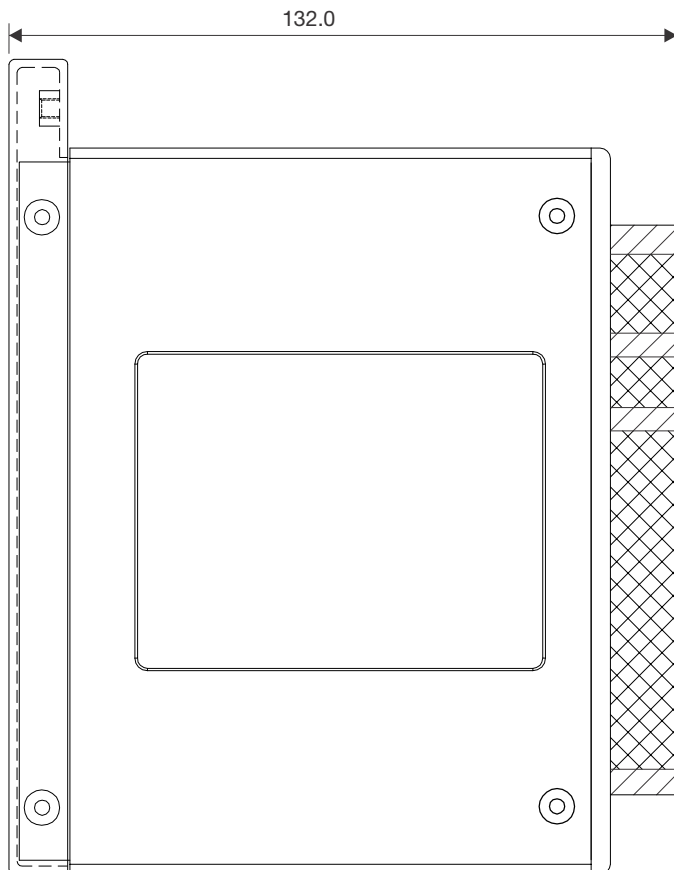

10. Ordering Information

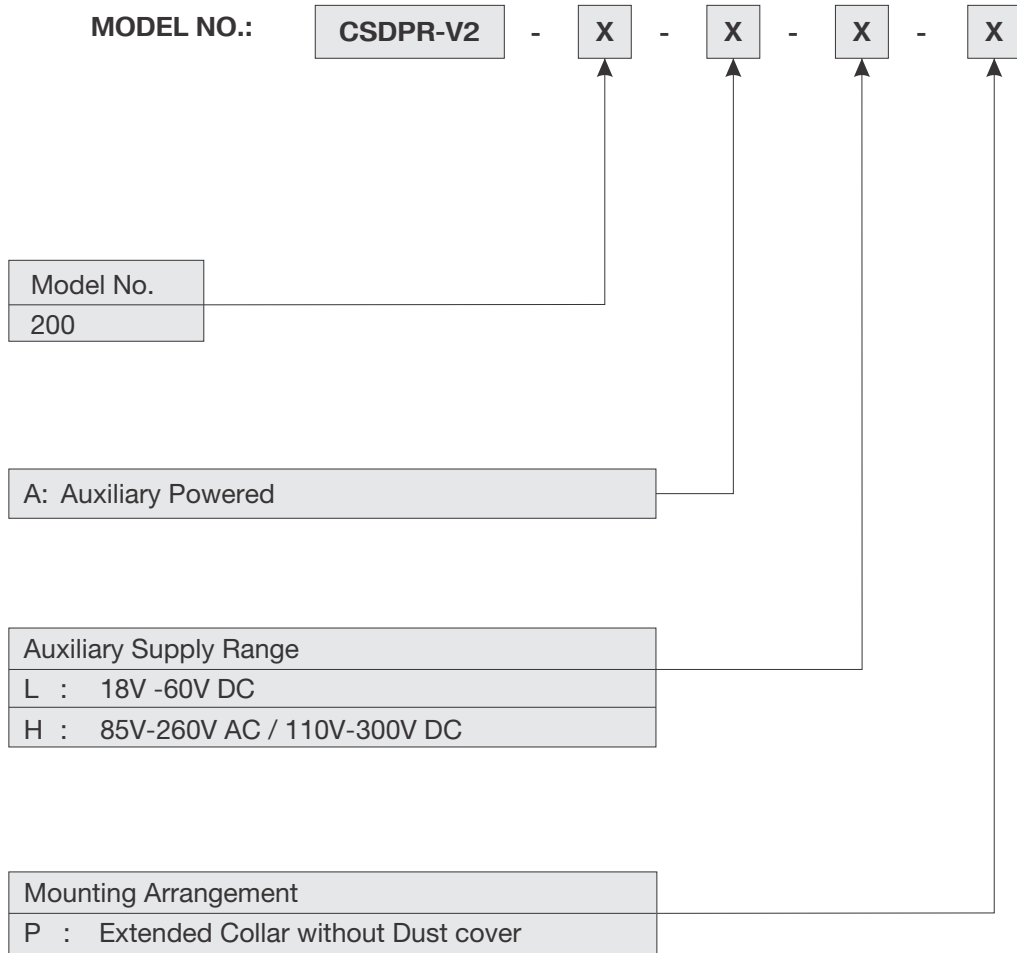

Example: CSDPR-V2-200-A-L/H-P

REVISION HISTORY

S.No.	Rev.No.	Details	Date
01	01	Change in "Ordering Information" and Clause 2.10 "Potential Input", "Conn Diagram" & "Term Description".	20.08.14

For further information, please contact:

C&S Electric Ltd.
(Protection & Measurement Devices)

C-60, Wing-A, Phase-II, Noida -201 305, District Gautam Budh Nagar (U.P) INDIA
 Phone : +91-120-305 7700 / 01, Fax: +91-120-305 7704
 E-mail: marketing.cspsc@cselectric.co.in



Issue Date : 12.08.14
 Rev. No : 02
 Rev. Date : 16.09.14

Branch office

Branch	Phone	Fax	E-mail
Ahmedabad:	+91 79 30074534/35/36	+91 79 30074519	cspc.ahmedabad@cselectric.co.in
Bangalore:	+91 80 3057 0372/73, 3057 0347	+91 2558 4839	cspc.bangalore@cselectric.co.in
Bhubaneswar:	+91 674 2507265	+91 674 2507265	cspc.bhubaneswar@cselectric.co.in
Chennai:	+91 44 3918 0531-35	+91 44 39180514	cspc.chennai@cselectric.co.in
Cochin:	+91 0484 3071717	+91 0484 3071716	cspc.cochin@cselectric.co.in
Delhi:	+91 11 30838822-25	+91 11 30838826	cspc.delhi@cselectric.co.in
Hyderabad:	+91 40 3918 2496/97	+91 40 3910 3631	cspc.hyderabad@cselectric.co.in
Kolkata:	+91 33 22275850/51	+91 33 2227 5849	cspc.kolkata@cselectric.co.in
Mumbai:	+91 22 30487146/47/48	+91 22 2412 6631	cspc.mumbai@cselectric.co.in
Pune:	+91 20 30283244/45	+91 20 30283244	cspc.pune@cselectric.co.in