

We touch your **electricity** everyday!

CSEZEN-F 200

Advance Feeder Protection & Monitoring IED



CSEZEN
CSEZEN
CSEZEN
CSEZEN

ZEN **E**-Series

Catalogue



PMD Division

CONTENTS

S.No.	Description
1.	Introduction
2.	Application
3.	Hardware
4.	Protection Features
5.	Supervision Functions
6.	Functional Diagram
7.	Protection Functions
8.	Data Acquisition Functions
9.	Fault Record
10.	Event Record
11.	Disturbance Record
12.	Communication
13.	Human Machine Interface
14.	Setting Ranges
15.	Technical Data
16.	Standards
17.	Recommended Terminal Lugs Specifications
18.	Connection Diagram
19.	Terminal Description
20.	(CT Conn Diagram (1A)
21.	(CT Conn Diagram (5A)
22.	Conn Diagram for Restricted Earth
23.	Trip Circuit Supervision Diagram
24.	Dimension Details
25.	Ordering Information

1.0 Introduction

CSEZEN series offers a multi functional comprehensive smart protection solution for Feeder, Generator, Motor & Transformer segment.

CSEZEN family of protective relays are advance numerical relays that provide multi protection and monitoring with reliable and fast protection solution in a single unit.

In this family of CSEZEN series, the CSEZEN-F is an advanced Feeder protection relay designed for controlling, protecting and monitoring industrial installations, public distribution networks and substations.

CSEZEN-F also provides an automation solution of power control. It complies with IEC 60870-5-103, IEC 61850, Modbus protocol for high integration of protection & control. CSEZEN-F offers following features in a compact & smart flush mounting enclosure.

- ❖ Programmable Rated Current 1A & 5A
- ❖ Measurement, Protection & Metering
- ❖ Draw-out enclosure have modular design with CT shorting
- ❖ Communication (Local & Remote)
- ❖ DI/DO/LED Matrix Programmability
- ❖ Intelligent key for DI & DO status, details of fault pickup & status of last fault occurred
- ❖ Last 20 fault record (non-volatile memory) with time stamp
- ❖ Last 500 event record (non-volatile memory) with time stamp
- ❖ Disturbance Recording
- ❖ CSEZEN-F relays are equipped with self supervision function

2.0 Application

CSEZEN-F relay will cover wide range of protection functions required for feeder segment. It can be used as part of protection scheme for transformers and generator transformers. CSEZEN-F relays can also provide back-up protection for HV and EHV transmission systems.

3.0 Hardware

- ❖ Digital Signal Processor based numeric design
- ❖ Measures true RMS with DFT filter
- ❖ 1A & 5A site selectable
- ❖ CT Terminal with self shorting
- ❖ 4 Current Analog Input
- ❖ Max.16 Digital Inputs
- ❖ Max.16 Digital Outputs
- ❖ 10 LED's at Pickup & Trip on fault
- ❖ LAN-RJ45/RS-485/USB ports for Communication
- ❖ 20x4 Alpha numeric LCD
- ❖ 11 Push button on the front for HMI
- ❖ Programmable Scheme Logic (PSL)

4.0 Protection Features

- ❖ Three Phase Time Over Current Protection (50/51P)
- ❖ Three Phase Instantaneous Over Current Protection (50)
- ❖ Ground Time Over Current (51N)
- ❖ Ground Instantaneous Over Current (50N)
- ❖ Derived Earth Over Current (50N)
- ❖ Negative Phase Sequence Over Current (46)
- ❖ Broken Conductor Detection (46BC)
- ❖ Auto Recloser (79)
- ❖ Cold Load Pickup (62 CLD)
- ❖ Thermal Overload (49)
- ❖ Three Phase Under Current (37P)
- ❖ Restricted Earth (64N)
- ❖ Harmonic Blocking (50H)

5.0 Supervision Functions

- ❖ Output Relay Latching (86)
- ❖ Open-Close Breaker Command
- ❖ Trip Circuit Supervision (74TC)
- ❖ Circuit Breaker Failure Protection (50 BF)
- ❖ Switch On To Fault (SOTF)

6.0 Functional Diagram

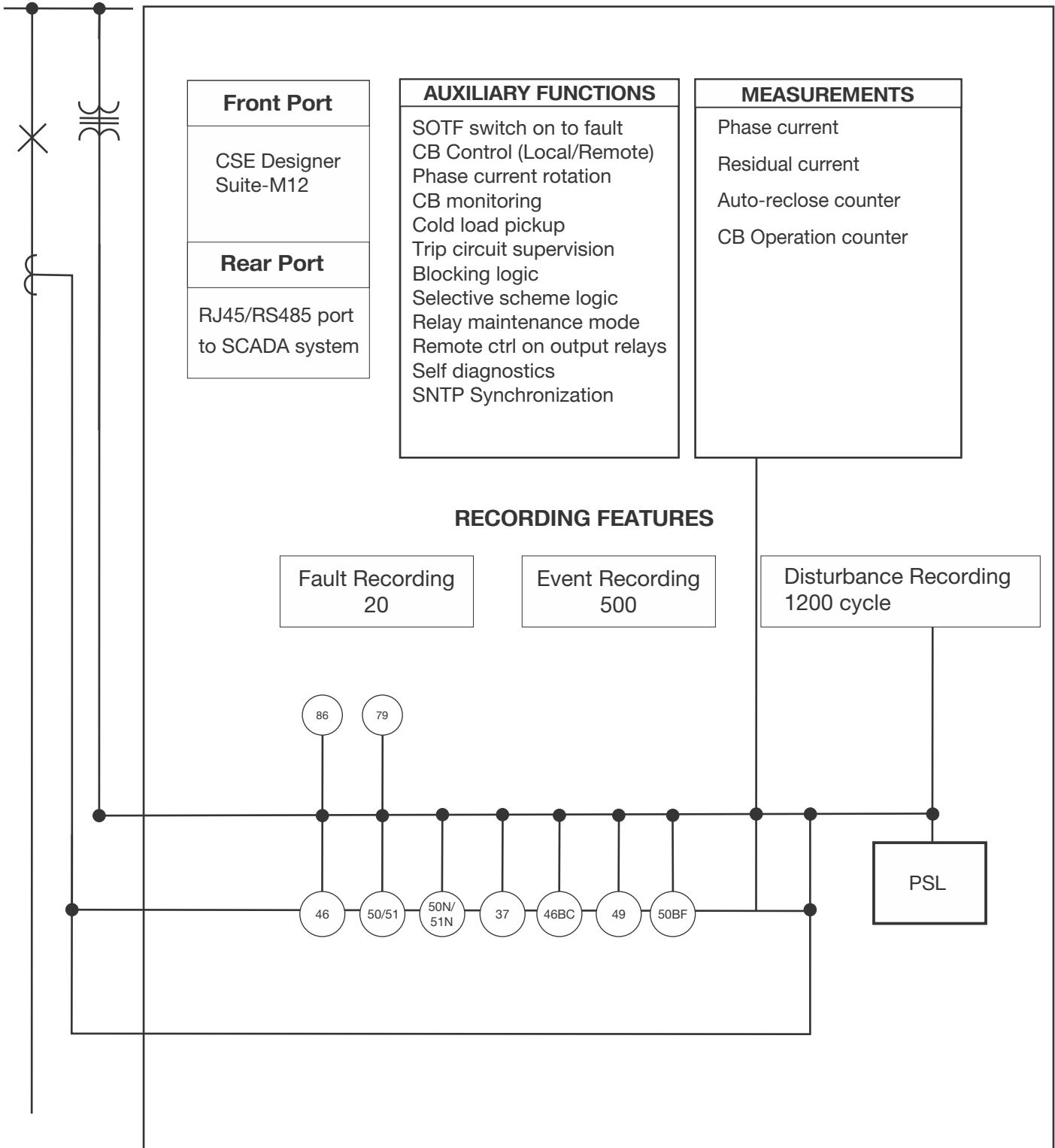

Figure-1

7.0 Protection Functions

1) Three Phase Over-current (50/51P)

Three Phase over current element (50P/51P) operates in a time period that depends on the applied current and on the set curve. The protection element trip when phase current exceeds the set current threshold for the set time.

The independent three stages are available for phase fault protection. For $I >$ & $I >>$ the user may independently select definite time delay or inverse time delay with different type of curves. The third Hi-set stage can be configured with definite time only. For three phase over current protections setting Refer Table-5.

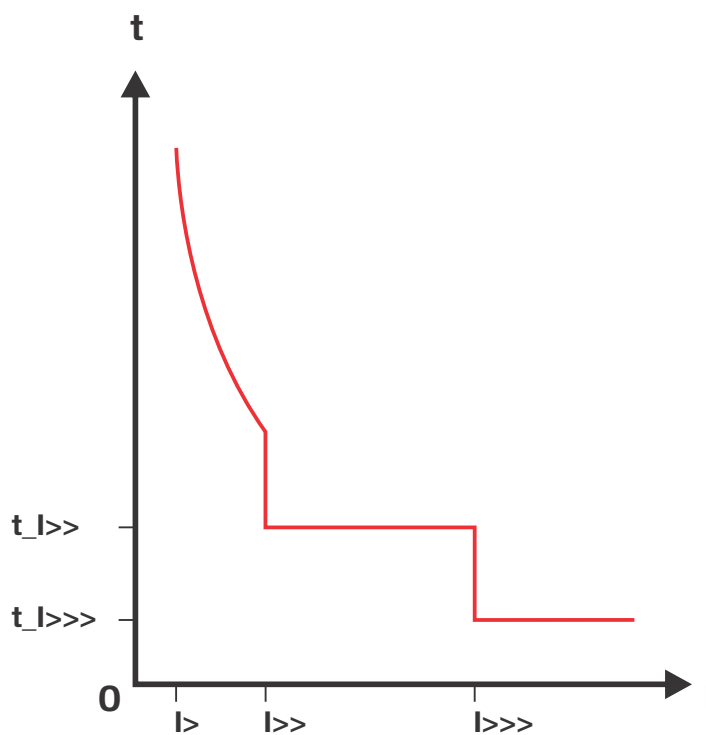

Over current Element

Figure-2

Inverse Characteristics Formula

Refer following formula for EINV, VINV, LINV, NINV1.3, NINV3.0 characteristics:

$$\text{Very Inverse} \quad t = \frac{13.5}{(I / I_s) - 1} \quad t_i \text{ [s]}$$

$$\text{Extremely Inverse} \quad t = \frac{80}{(I / I_s)^2 - 1} \quad t_i \text{ [s]}$$

$$\text{Long time Inverse} \quad t = \frac{120}{(I / I_s) - 1} \quad t_i \text{ [s]}$$

$$\text{Normal Inverse 3.0/1.3/0.6} \quad t = \frac{0.14/0.061/0.028}{(I / I_s)^{0.02} - 1} \quad t_i \text{ [s]}$$

Where t = Tripping time
 I = Fault current
 t_i = Time multiplier
 I_s = Setting value of current

2) Earth Over current (50N/51N)

The earth current is measured from the earth input terminals B13-B15/B14-B16.

The independent two stages ($I_{e>}$ & $I_{e>>}$) are available for earth fault protection. For first stage ($I_{e>}$) the user can select definite time delay or inverse time delay with different type of curves. The second Hi-Set stage ($I_{e>>}$) can be configured with definite time only.

Refer Inverse characteristics Formula.

Refer Table for Earth over current setting-5.

3) Derived Earth Over current (50N)

The derived earth over current element protection is used to cover application such as HTB/HTA transformers. The derived earth current ($I_{e_d>}$) is the vector summation:

$$I_{e_d} = (\vec{I}_{L1} + \vec{I}_{L2} + \vec{I}_{L3})$$

The derived earth over current has two independent thresholds: $I_{e_d>}$ and $I_{e_d>>}$.

Refer Table-4 for Earth over current setting.

4) Restricted Earth Protection (64N)

The restricted earth fault relay is high impedance differential scheme which balances zero sequence current flowing in the transformer neutral against zero sequence current flowing in the transformer phase windings. Any unbalance for in-zone fault will result in an increasing voltage on the CT secondary and thus will activate the REF protection.

This scheme is very sensitive and can then protect against low levels of fault current in resistance grounded systems where the earthing impedance and the fault voltage limit the fault current.

In addition, this scheme can be used in a solidly grounded system.

For Restricted Earth Fault Protection settings Refer Table-5.

5) Negative Phase Sequence Over current (46)

This function protects against current unbalances resulting from anomalies in the power System or unbalanced loads. Negative phase sequence over current element give greater sensitivity to resistive phase to phase faults, where phase overcurrent element may not operate.

If I_2 is Negative phase sequence current then

$$3 \cdot |I_2| = |I_a + a^2 \cdot I_b + a \cdot I_c| \quad \text{Where } a = 1 \angle 120^\circ$$

The Trip can be time delayed by a curve selectable by settings.

Refer following formula for the inverse characteristics of Negative Phase Sequence protection: -

Negative Phase Sequence Equation

$$t = \frac{K1}{(I_2/I_{2s})^2 - 1}$$

$K1$: TMS for Inverse characteristics of NPS

t : Expected Trip Time

I_2 : Measured negative sequence value

I_{2s} : Permissible NPS value

Refer Table-9 for Negative Phase Sequence over current setting.

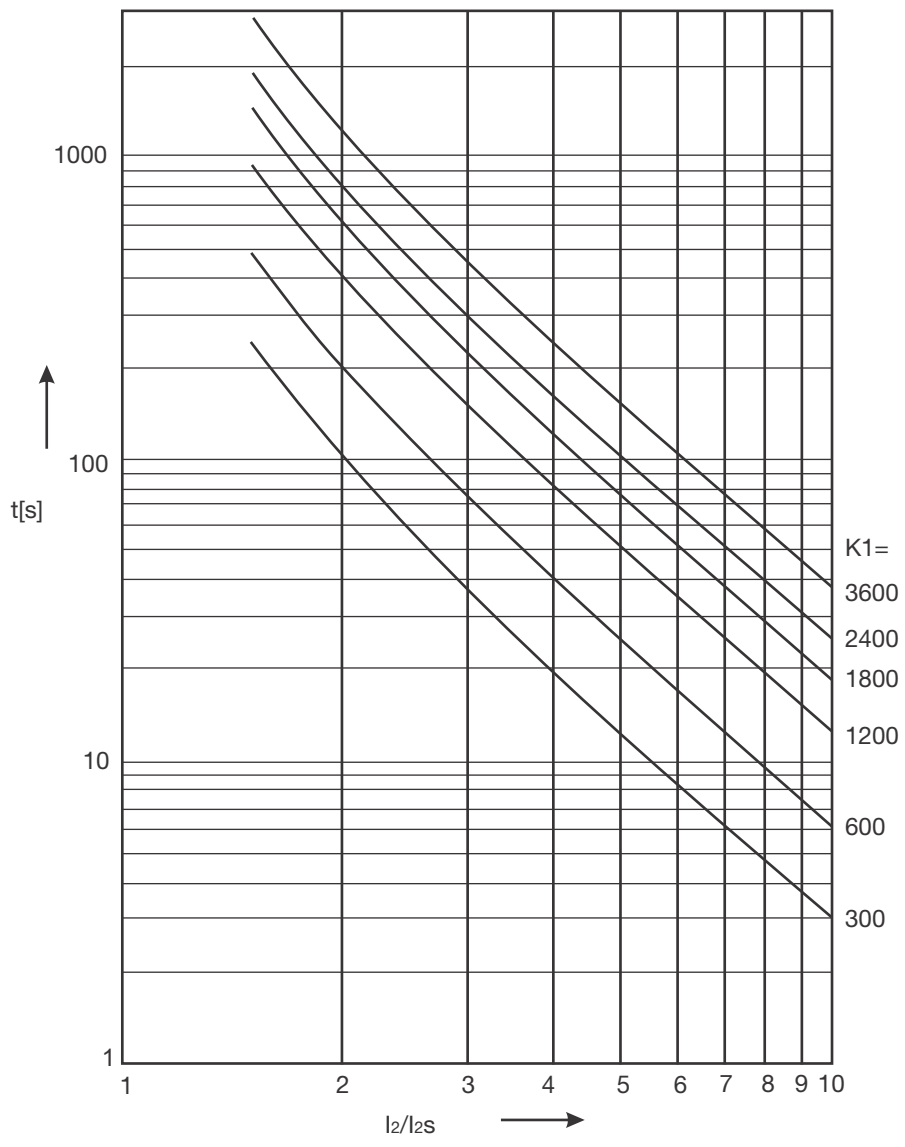

Figure-3

Negative Phase Sequence Inverse Time Characteristics

6) Three Phase Under current (37)

The undercurrent protection makes it possible to detect a loss of load (for example the draining of a pump or breakage of a conveyor belt). If the phase current goes below the programmed undercurrent threshold for a programmed definite time the trip signal is given.

For undercurrent protection settings Refer Table-8.

7) Thermal Over load Protection (49)

Thermal overload protection can be applied to prevent damages to the electrical plant equipment when operating at temperatures in excess of the designed maximum withstand. A prolonged over loading causes excessive heating, which may result in premature deterioration of the insulation or in extreme cases, insulation failure.

CSEZEN relays incorporate a current based thermal replica, using load current to reproduce the heating and cooling of the equipment to be protected. The element thermal overload protection can be set with both alarm and trip stages.

The heating within any plant equipment, such as cables or transformers, is of resistive type ($I^2R \times t$), thus the quantity of heat generated is directly proportional to current squared (I^2). The thermal time characteristics used in the relay is based on current squared, integrated over time.

The CSEZEN relays automatically use the highest phase current as input information for the thermal model. Refer Table-17 for Thermal overload protection settings. Thermal protection can be inhibited on start-up. The thermal time characteristic is given by following formula:-

The formula for calculating the trip characteristics is as follows:

$$\text{Trip time } (t_{\text{aus}}) = \tau \cdot \ln \left[\frac{\left(\frac{I^2}{I_b^2} \right) - p^2}{\left(\frac{I^2}{I_b^2} \right) - k^2} \right] \quad \text{for } p^2 < \frac{I^2}{(I_b^2)} \text{ and } p^2 \leq k^2$$

with τ = thermal time constant of the object to be protected.

I_b = Basic current

I_p = Initial load current

P = Initial load factor ($p = 0$ means cold operating component)

k = constant

for thermal characteristics user has two choices

(1) Thermal based on highest measured RMS current

$$I = \sqrt{I_1^2 + I_2^2 + I_0^2}$$

OR

(2) Thermal based on positive & negative sequence measured.

$$I = \sqrt{I_1^2 + \text{Neg}_k \times I_2^2}$$

where

I_0 = Zero phase sequence current (ZPS)

I_1 = Positive phase sequence current (PPS)

I_2 = Negative phase sequence current (NPS)

Neg_k = is weighting factor of NPS (constant value)

In CSEZEN relay three modes are available for saving of thermal memory during power reset. These modes are programmable.

M1: On Power Reset thermal memory becomes 0.

M2: On Power Reset thermal memory starts from the same value as at the time of Power Off.

M3: On Power Reset thermal memory subtracts for the time it is in Off state & starts from the remaining value.

Presentation of the Trip with variable initial load factor:

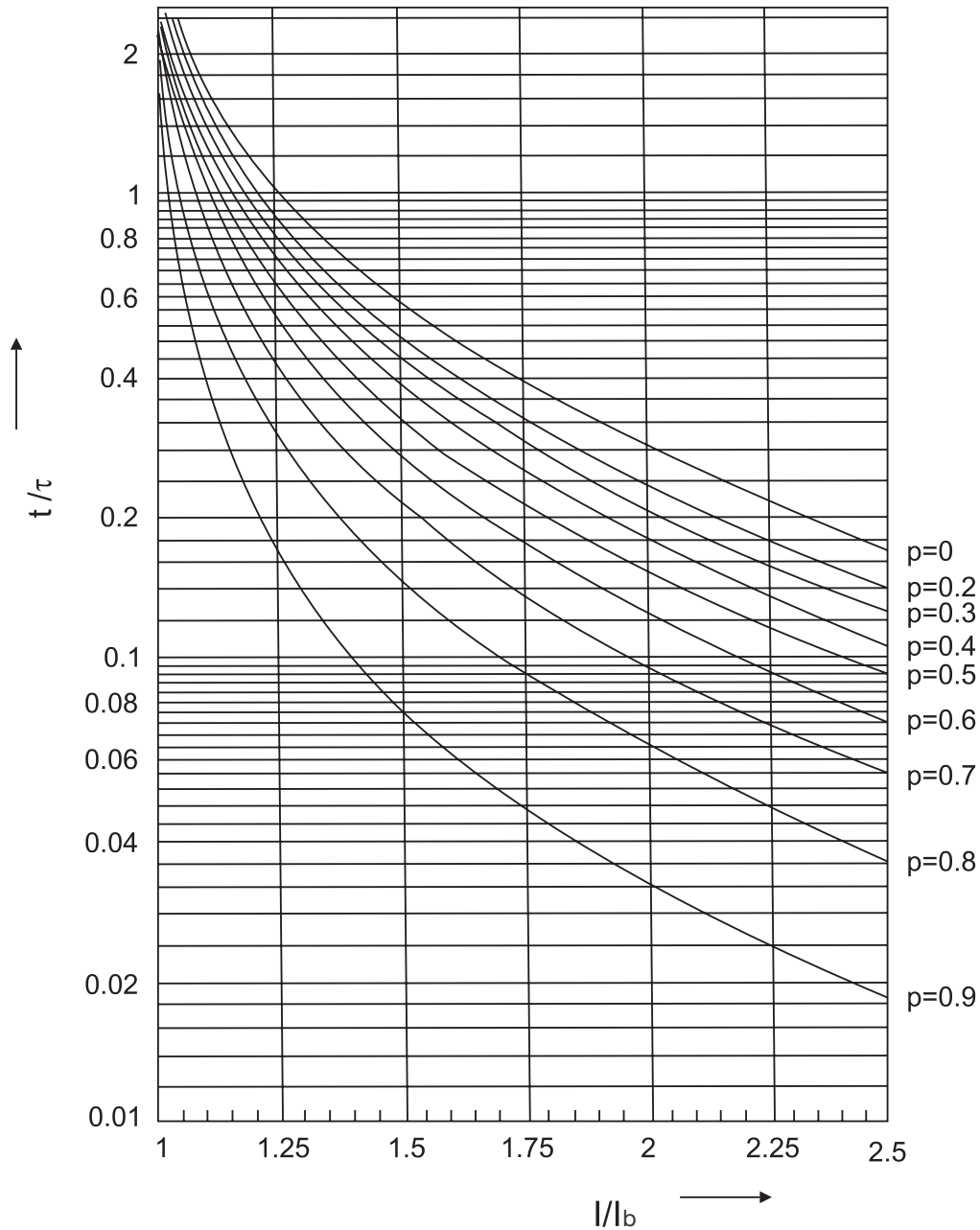

Figure-4

8) Broken Conductor Protection (46BC)

Majority of faults on a power system are shunt faults and induce appreciable current increase so easily detectable by standard over current protection element.

Another type of unbalanced system condition is the series or open circuit fault. This fault can arise from broken conductors, mal operation of single phase switchgear or the operation of fuses.

Series faults will not induce an increase in phase current on the system and hence are not easily detectable. However on a lightly loaded line, the negative sequence current resulting from a series fault condition may be very close to or less than the full load steady state unbalance arising from CT errors, load unbalance etc. a negative sequence protection element therefore would not operate at low load levels.

CSEZEN relays incorporate a protection element, which measures the ratio of negative to positive phase sequence current (I_2/I_1). This protection element will be affected to a lesser extent than the measurement of negative sequence current alone, since the ratio is approximately constant with variations in load current. Hence a more sensitive setting may be achieved.

Refer Table -15 for Broken conductor protection settings.

9) Auto Re-closer Strategy (79)

As 80% of faults in overhead lines are transient, the use of the auto recloser is very advantageous. Automatic auto-recloser allows a substation to operate unattended. The number of visits on site to manually reclose a circuit breaker after a fault, can then be substantially reduced. This feature gives an important advantage for substations supervised remotely.

Typically this auto reclose (AR) sequence of Instantaneous Trip(s) and Reclose Delays (Dead times) followed by Delayed Trip(s) provide the automatic optimum method of clearing all types of faults i.e. both Transient and Permanent, as quickly as possible and helps in improving the up time of the network in service.

DI Inputs

- AR Blocking - To block the auto re-closer through remote DI
- CB Close DI - To get the circuit breaker status
- CB Ready - To get the CB ready or to give the closing command

Configurable Outputs:

- 79 AR Close
- 79 Lockout

AR - Blocked

Unit changes immediately to "AR-blocked" status when an external AR Blocking DI is applied or internal EXIT is chosen for AR cycle in HMI. No Auto reclosing is possible in "AR-blocked" status.

Activating of AR

Prior to every AR it is possible to select which kind of tripping (I> or I>>, Ie>, I>>> etc.) will lead to automatic reclosing. This can be separately fixed for each protection.

Dead time (td)

Starts with the off signal of the circuit breaker. No closing command to the circuit breaker is given till expiry of the set dead time.

User programmable dead times are available for each protection trip operation.

The dead time is initiated when the trip output contact resets, the pickup is reset and the CB is open.

The CB close output relay is energized after the dead time has elapsed If CB ready input is present.

The dead time (dead time td1, dead time td2 dead time td3 dead time td4) starts when the feedback on 'CB CLOSE DI' is not available.

Reclaim time (tr)

This is the time during which after switching on or after AR a subsequent reclosing is prevented.

If the number of the set shots is reached, the relay is locked for this time after the last reclosing attempt.

If CB Ready DI is not available relay will not generate closing command.

If the circuit breaker dose not trip again, the auto re-close cycle resets to original STATE-1 at the end of the reclaim time.

After Successful re-closure the relays goes to the lock out state.

- ◆ If the protection operates during the reclaim time of the relay:
- ◆ either advances to the next AR cycle that is expected in next auto re-close state or if all the programmed re-closer attempts have been accomplished, it locks out.

The reclaim time is started with the automatic closing command.

Once a CB has reclosed and remained closed for a specified time period (the reclaim time), the AR sequence is reinitialized and a successful close output issued. A single common reclaim time is used (Reclaim Timer). when an auto reclose sequence does not result in a Starting Condition for Auto recloser

- 1) AR should be enabled by manual setting.
- 2) AR blocked DI is not available
- 3) Respective protection AR cycle should not in exit condition.

Lock out State:

Lockout state of the breaker means no further attempts to AR in these conditions

- 1) Lockout occurs when all auto reclosure attempts are over and protection operates during the final Reclaim Time.
- 2) If CBFP failure appeared in relay (if CBFP enable).
- 3) At the end of the each reclaim timer if the CB is in the open position (Close DI is not present).
- 4) If a Close pulse of AR relay is given and the CB fails to close through close DI input or expiry of Trip Contact Sense time.
- 5) If a open pulse given to CB and CB fails to open in between Trip Contact Sense time.

In any of these cases, Manual reset will be required to reinitiate the AR.

Refer Table-16 for Auto Re-closer settings.

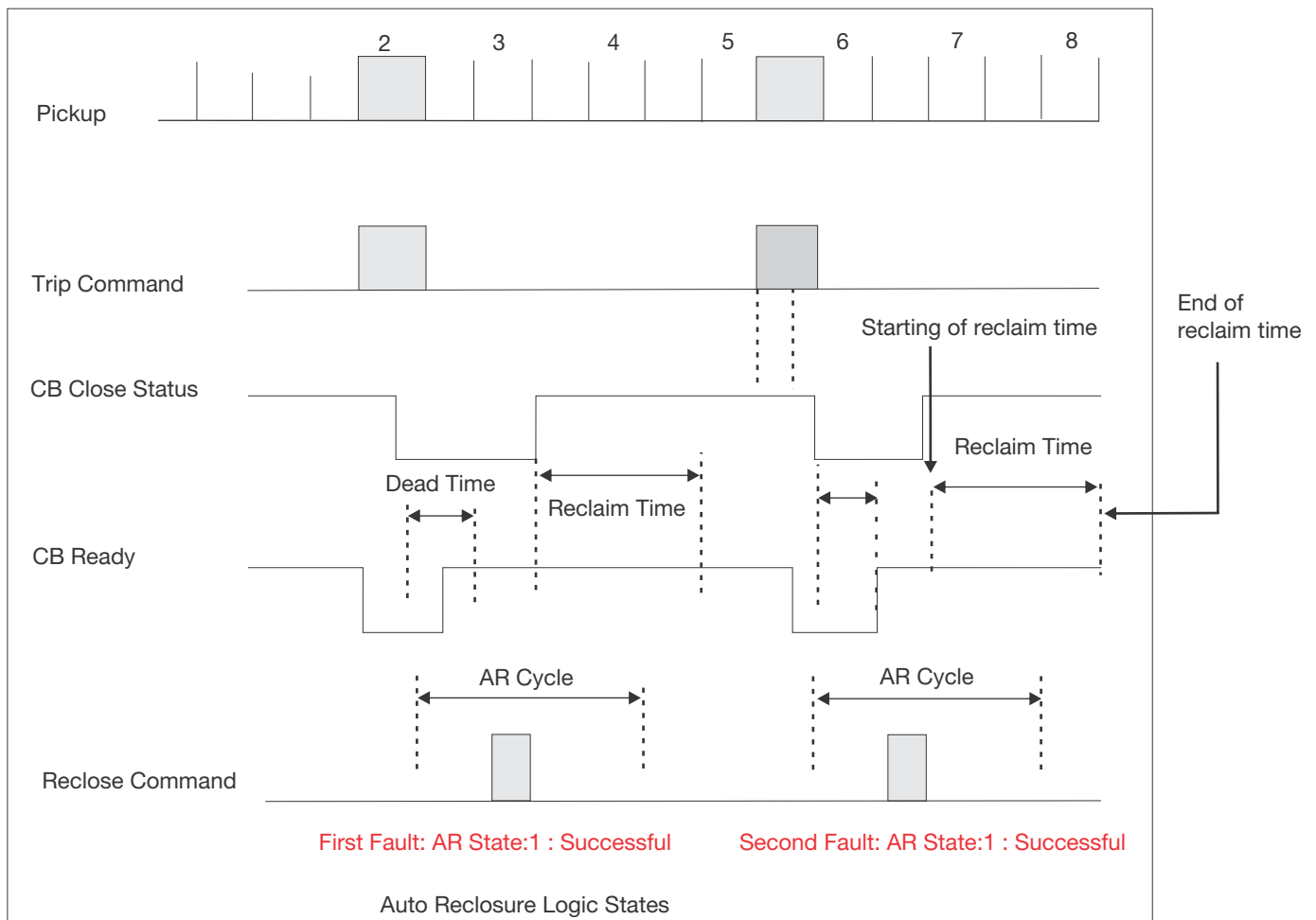

Figure-5

10) Cold Load Pickup

This function aims to avoid non-desired trips in the following situation: after being the line de-energized for a period of time and re-energized later, the load can exceed the protection setting without the presence of a fault. This may be due to the accumulative inrush current caused when connecting all the loads (furnaces, heaters, coolers etc.) at the same time. CSEZEN relay is detecting when those conditions are given and replacing the active group setting during a programmable time by group4 settings.

In group4 cold load setting will be same as those in active group so in group4 except cold load setting all other protection setting values are programmable. For Cold Load Pickup settings Refer Table-10.

11) Harmonic Blocking

In the CSEZEN relays, starting of the phase current and earth current stage can be blocked under inrush conditions to avoid unsuitable trip during transformer magnetization.

As soon as the ratio of second harmonic component is above the programmed value (in percentage) then selected over current and earth protection will be blocked for a settable duration.

Refer Table-7, For Harmonic Blocking Settings.

12) Circuit Breaker Failure Protection (50BF)

The CB failure protection is based on supervision of phase currents and earth current after tripping events. The test criterion is whether all phase currents have dropped to less than 5% of Nominal value of rated current within the set time (tCBFP). If one or more of the phase currents have not dropped to specified current within this time, CB failure is detected and the assigned output relay is activated.

Refer Table-6 for Circuit breaker failure protection settings.

13) Trip Circuit Supervision (74TC)

This feature detects any anomalies in the circuit with the switch open or close. It detects trip circuit supply failure of circuit breaker, tripping mechanism failure like circuit breaker contact degeneration in wires, contacts and coils.

For Trip circuit supervision settings, Refer Table-2.

14) Output Relay Latching (86)

Any digital output can be latched. Reset of the latched output is possible by logic input front panel operator interface or by remote communication or through RESET key.

15) Blocking Logic

CSEZEN relay includes logic inputs, which can be configured to block the selected protection functions. Each protection functions can be locked via a digital input as selected and assigned.

16) Test of Output Relays

Select the 'TRIP TEST' menu from HMI, then by using backward/forward key it will start operating the output relay's & LED's one by one unless the enter key is pressed again.

17) Local / Remote CB Control

In CSEZEN-F circuit breaker control can be done locally using front key's whereas same can be controlled remotely using configurable DI's as well as communication mode.

18) Selective Relay Scheme Logic

CSEZEN-F relays include selective logic scheme for various protection functions.

19) Switch on to Fault Protection

Under particular conditions, it can happen that when the feeder is supplied by the closing of the CB a fast trip command may be required if a fault is present (closing on to burden).

Some faults may be caused by conditions not removed from the feeder after a reclosing cycle or a manual trip or due to earthed clamps left on after maintenance works. In these cases, it may be desirable to clear the fault condition in fast time, rather than waiting for the Trip time delay associated with the I>> & I>>> protection. t_SOTF time delay is used for I>> & I>>> protection's in such condition's.

With the switch on to fault (SOTF) submenu, it is possible to shorten the time to trip For I>> & I>>> protection if selected, when for example the relay has detected a fault that is still present on a feeder after energizing.

20) Setting Group

CSEZEN-F relays have four protection related setting groups. Changes between the groups are executed via the front interface, a dedicated logic input or through the communication port.

To avoid any undesirable tripping, the setting group change is only executed when none of the protection functions are running (deactivated or inhibited).

Refer Common Setting Menu Table-19 to change active group of the relay.

21) Phase Current Rotation

In some applications, there is a need to match the plant phase sequence with the connected relay. Without changing the cabling CSEZEN-F relays include the phase rotation feature that allows the setting of the phases in clockwise or in anti clockwise rotation (1-2-3 or 1-3-2 sequence).

Time Synchronization

Inside CSEZen there is an internal time clock. Relay supports SNTP Protocol (ordering based). SNTP (Simple network Time Protocol) have mechanisms within the protocol to synchronize the clock and keep it accurate to certain accuracy. The protocol itself has the ability to send commands and re-synchronize the clock so that each attached IED using its synchronization capability on the network is accurate within resolution.. The relay makes the synchronization automatically using SNTP protocol. The internal clock of the relay is synchronized to the UTC time of the NTP server.

8.0 Data Acquisition Function

Measurement

- ❖ 3 Phase Current
- ❖ Earth current measurement
- ❖ Derived earth current measurement
- ❖ Negative / Positive phase sequence current
- ❖ Trip counter
- ❖ Thermal memory
- ❖ AR cycles
- ❖ I1/I2 (Positive Phase Sequence current / Negative Phase Sequence current)

9.0 Fault Record

CSEZEN-F records last 20 faults in its non volatile memory with its time stamp. Each record has the following information:

Fault Format		
l11	:	XX.XXA
l12	:	XX.XXA
l13	:	XX.XXA
le	:	XX.XXA
le_d	:	XX.XXA
l2	:	XX.XXA
Them_mem	:	XXXX%
HR MIN	:	HH:MIN
SEC Ms	:	Sec: mSec
DATE	:	DD:MM:YY
F-TYPE	:	Type of fault

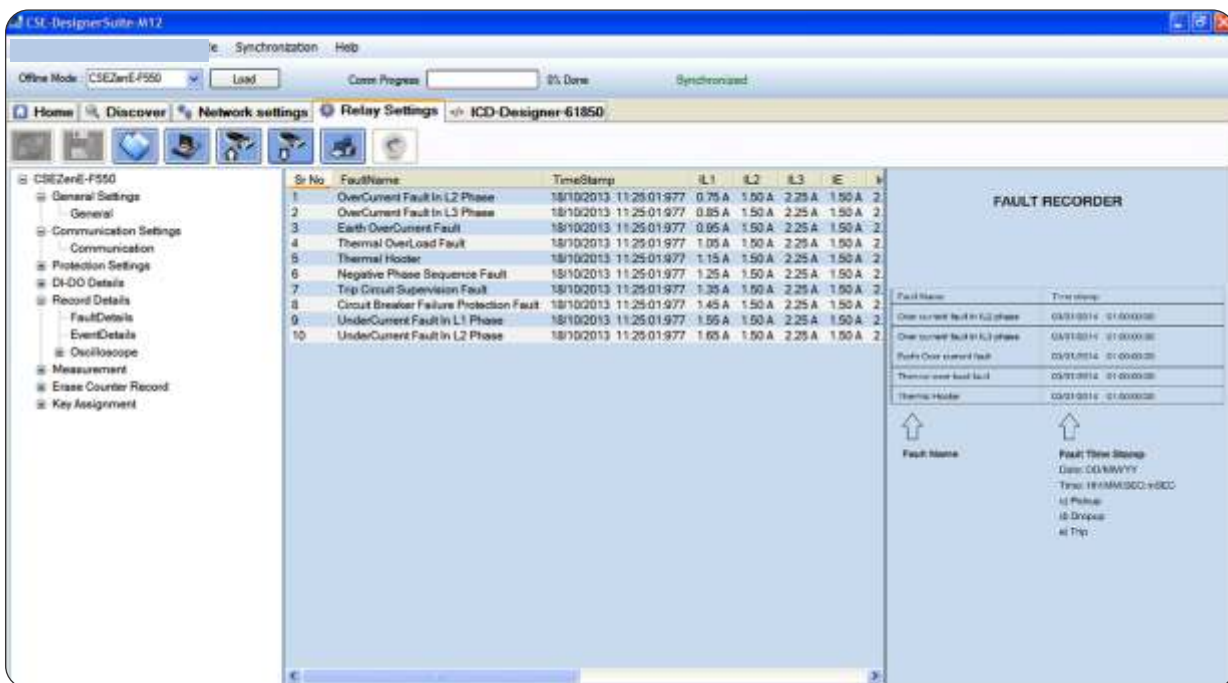

Fault Data recording on PC software

Figure-6

10.0 Event Record

The unit stores in non volatile memory the last 500 events with it's time stamp. When the available memory space is exhausted, the new event automatically overwrites the oldest event, which can be retrieved from a PC.

The user can view event records via the front USB interface software.

The screenshot displays the ICD-Designer-61850 software interface. On the left, there is a navigation tree for 'CSEZero-F550' with categories like General Settings, Communication Settings, Protection Settings, and Record Details. The main window shows a table of event records. Below the table, there is an 'EVENT RECORDER' section with a legend for event names and categories, and a date/time stamp format: 'Date: DD/MM/YYYY' and 'Year: HH:MM:SS+GGG'.

S.No	Event Name	Event Category	Time Stamp
1	Power ON	CONTROL	18/10/2013 11:25:01:30
2	Clock Change	SETTING	18/10/2013 11:25:01:30
3	Circuit Breaker NO contact Close	CONTROL	18/10/2013 11:25:01:31
4	Circuit Breaker NC contact Open	CONTROL	18/10/2013 11:25:01:31
5	Pickup due to Overcurrent in IL1 Phase	PICKUP	18/10/2013 11:25:01:32
6	Pickup due to Overcurrent in IL2 Phase	PICKUP	18/10/2013 11:25:01:32
7	Pickup due to Overcurrent in IL3 Phase	PICKUP	18/10/2013 11:25:01:33
8	Relay Pickup Earth	PICKUP	18/10/2013 11:25:01:33
9	Pickup due to Short circuit in IL1 Phase	PICKUP	18/10/2013 11:25:01:34
10	Pickup due to Short circuit in IL2 Phase	PICKUP	18/10/2013 11:25:01:34
11	Pickup due to Short circuit in IL3 Phase	PICKUP	18/10/2013 11:25:01:35
12	Pickup due to High Earth in E-Phase	PICKUP	18/10/2013 11:25:01:35
13	pickup due to instant short circuit in IL1 Phase	PICKUP	18/10/2013 11:25:01:36
14	pickup due to instant short circuit in IL2 Phase	PICKUP	18/10/2013 11:25:01:36
15	pickup due to instant short circuit in IL3 Phase	PICKUP	18/10/2013 11:25:01:37
16	pickup due to instant high earth	PICKUP	18/10/2013 11:25:01:37
17	Pickup due to negative phase sequence	PICKUP	18/10/2013 11:25:01:38
18	Pickup due to thermal load in IL1 phase	PICKUP	18/10/2013 11:25:01:38
19	Pickup due to thermal load in IL2 phase	PICKUP	18/10/2013 11:25:01:39
20	Pickup due to thermal load in IL3 phase	PICKUP	18/10/2013 11:25:01:39
21	Pickup due to thermal load in E phase	PICKUP	18/10/2013 11:25:01:40
22	Pickup due to broken conductor	PICKUP	18/10/2013 11:25:01:40
23	Relay dropout due to Overcurrent fault in IL1 Phase	DROPUF	18/10/2013 11:25:01:41
24	Relay dropout due to Overcurrent fault in IL2 Phase	DROPUF	18/10/2013 11:25:01:41
25	Relay dropout due to Overcurrent fault in IL3 Phase	DROPUF	18/10/2013 11:25:01:42
26	Relay dropout due to Overcurrent fault in E-Phase	DROPUF	18/10/2013 11:25:01:42
27	Relay dropout due to short circuit fault in IL1 Phase	DROPUF	18/10/2013 11:25:01:43
28	Relay dropout due to short circuit fault in IL2 Phase	DROPUF	18/10/2013 11:25:01:43
29	Relay dropout due to short circuit fault in IL3 Phase	DROPUF	18/10/2013 11:25:01:44
30	Relay dropout due to high earth	DROPUF	18/10/2013 11:25:01:44
31	Relay dropout due to instant short circuit fault in IL1 Phase	DROPUF	18/10/2013 11:25:01:45

Event Data recording on PC Software

Figure-7

11.0 Disturbance Record

The CSEZEN-F relay has an oscillograph data recorder with the following characteristics:

- ❖ Oscilloscopic recording can trigger on Pickup or on trip or via DI i.e. change from pre-fault to post-fault stage. It is programmable.
- ❖ Each record comprises the samples from max. 4 analog signals (depends upon the different models) and the status of maximum 16 digital inputs and maximum 16 digital outputs. There will be 30 samples per cycle.
- ❖ Relay saves maximum 1200 cycles, and the number of cycles per record is programmable which limits the maximum no. of records possible to store in the relay (for example: if 40 cycles are selected, then there will be maximum 30 records of 40 cycles each).
- ❖ The pre-fault and post-fault cycles are programmable.
- ❖ Records are in the non volatile memory.
- ❖ The records are transferred to PC using USB interface. The data is graphically displayed and can be taken on printer.
- ❖ Record 1 is always latest record. 2nd record is older than 1st..... and so on.
- ❖ Disturbance record is available in comtrade format as per IEC60255-24.



Oscilloscope recording on PC software

Figure-8

Output Contacts

Max. No. of digital outputs	:	16 (DO1, DO2DO16)
Type of outputs	:	Relay
Programmable (DO Assignment)	:	Yes (Max. 15 DO are programmable and 1 is fixed for self supervision function)
Relay reset type	:	Programmable (Auto/Manual)

Input Contacts

Max. No of digital inputs	:	16 (DI1, DI2..... DI 16)
Type of inputs	:	AC/DC Voltage
Programmable (DI Assignment)	:	Yes

12.0 Communication (Local & Remote)

The unit has:

- ❖ 1 Front USB port for direct connection to a PC.
- ❖ 1 Rear RS-485 communication port.
- ❖ 1 Rear terminal RJ-45 communication port.

Dual Rear Communication

The communication protocol for the rear port is available in IEC 61850 on RJ-45 and IEC 870-5-103 protocol on RS-485 communication.

Front Communication (USB)

The entire setting including protection parameter setting for both group, Fault, Event & Disturbance record are available on 'Mini-B to A' type USB (female) interface with CSE LIVELINK with saving & printing option. This unit also has Front-end Live Link simulation support for testing of relay even without any three phase injection source.

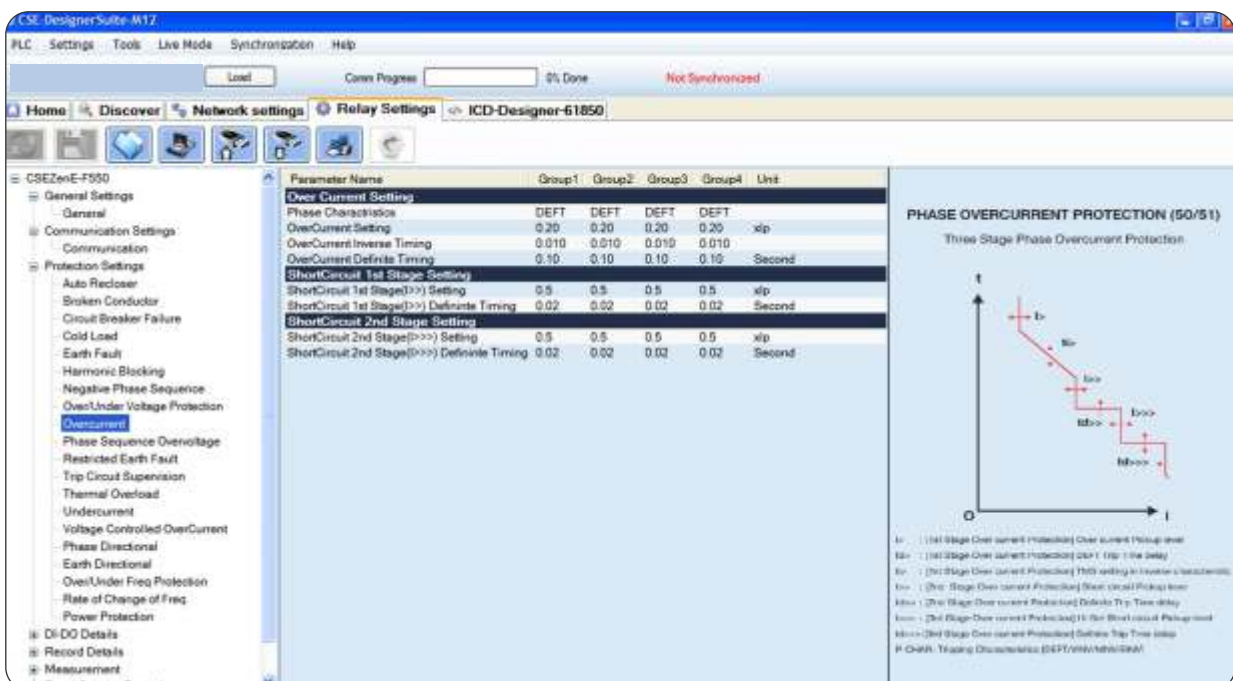

Figure-9

13.0 Human Machine Interface

CSEZEN-F offers a variety of front user interfaces, including:

Human-Machine Interface (HMI)

It comprises of 20x4 Alpha numeric display and 11 push buttons for setting and other operations for local access:

- ❖ Two push switches for set values of normal tripping characteristics.
- ❖ One 'RESET' push switch & One 'ENTER' push switch.
- ❖ One intelligent (I) Key.
- ❖ One push switch for the tripping of relay assigned to 'F1' Key.
- ❖ Two push switches for the tripping of relay assigned to Circuit breaker open & Circuit breaker close.
- ❖ Ten LEDs for pickup or tripping on fault's & events in any phase.

In order to change any setting first press enter then only (◀ / ▶) key will act as decrement/increment else these key will function as scroll in backward/forward direction.

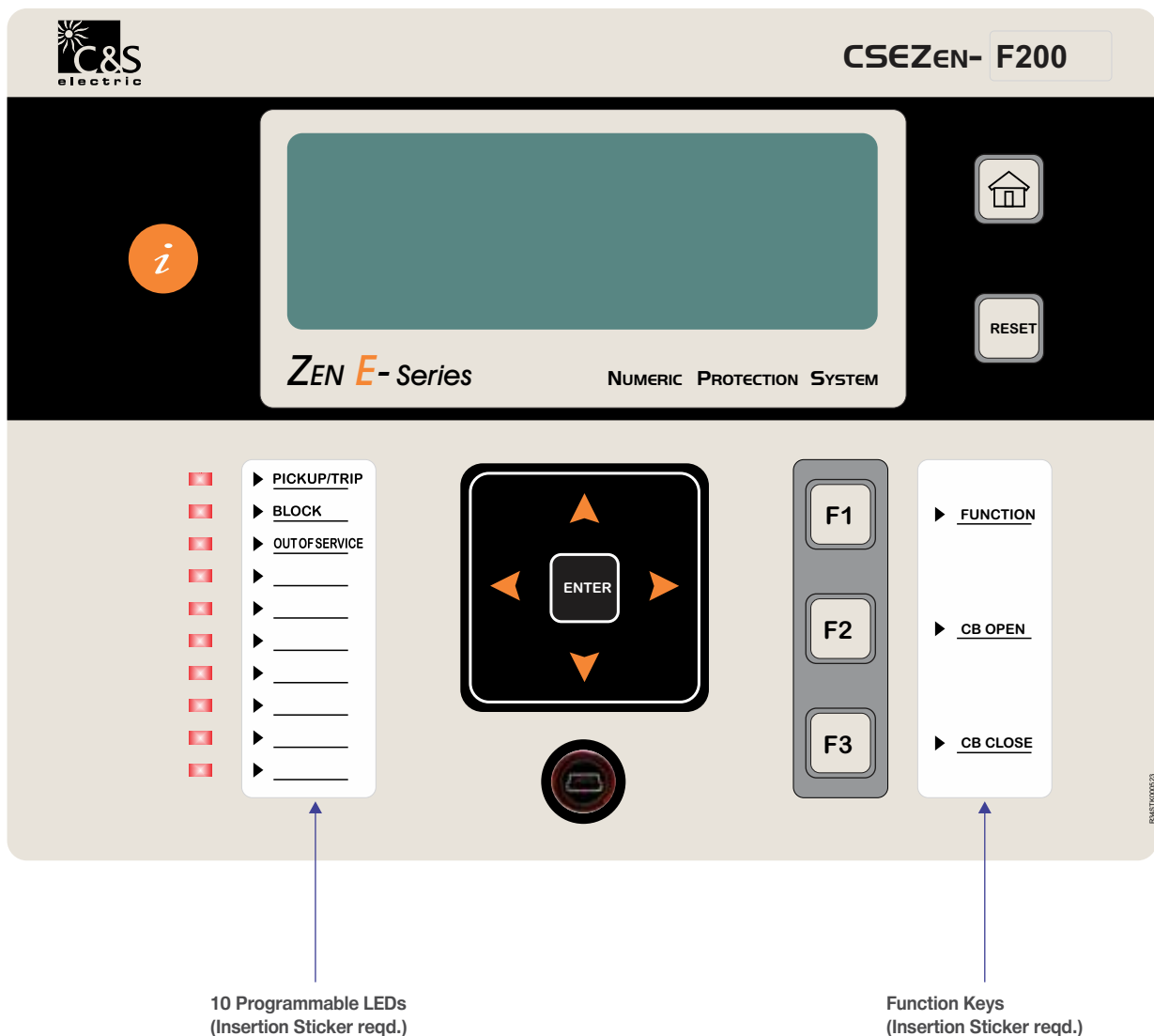













Figure-10

Key Description

Keys	Manual Key
	is used as intelligent key to see the details of the fault pickup / digital input / output status & last fault details / LED Status.
	is used as a “HOME” key.
	is used as a “RESET” key.
	is used as a “ENTER” key.
	is used to scroll in upward direction for parameters.
	is used to scroll in downward direction for parameters.
	is used to scroll in backward direction and for decrement of parameters.
	is used to scroll in forward direction and for increment of parameters.
	is used as a “FUNCTION” key.
	is used as a “CB Open” key.
	is used as a “CB Close” key.

LED Description

In CSEZEN Relay Ten LEDs are given for pickup or tripping on faults & events in any phase. 3 LEDs are fix

- | | |
|-------------------|--|
| 1) PICKUP/TRIP | Relay is in Pickup / Trip mode |
| 2) BLOCK | Some protection function is blocked |
| 3) OUT OF SERVICE | Relay is in out of service mode (Protection on hold) |

5 LED's are programmable via front end software CSE Designer Suite - M12, 10 of which are in front fascia. For these 10 LED's protection function naming sticker is needed to be inserted.

USB Description

CSE Designer Suite - M12

USB port is available as HOST & OTG. PC/Laptop can be interfaced via USB port for connecting with CSE Designer Suite - M12 Front End Software. USB Pen drive can also be connected on this port via OTG cable for downloading / uploading the setting / record details.

Programmable Scheme Logic

Programmable scheme logic is configured using the front end interface CSE Designer suite-M12. This interface uses Boolean equations. Flexible logic allows user to create logic diagram to be assigned digital output.

The designed logic is event driven to ensure that protection is not delayed.

The following figure describes the use of protection schemes using the over current pickup & under voltage pickup from downstream relays to block operation of upstream relays using a digital output.

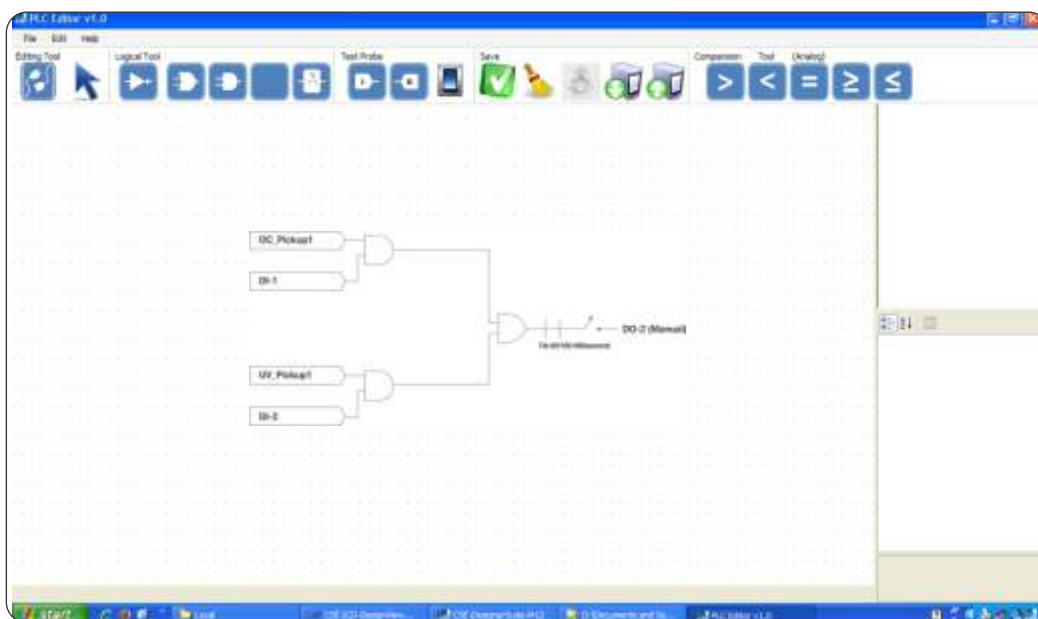

Figure-11

14.0 Setting Ranges

Active Group Setting

Parameters	Display	Setting Range		Step Size	Default Setting
		Min	Max		
Active Group	ACTIVE GROUP	GROUP1	GROUP4	-	GROUP1
Group Toggle Step	TOGGLE STEP	+1	+3	1	+1

(Table-1)

Trip Circuit Supervision Setting

Parameters	Display	Setting Range		Step Size	Default Setting
		Min	Max		
Trip circuit supervision	TCS Deft time	0.03sec	2.00sec	0.01sec	Disable

(Table-2)

Negative Phase Sequence Protection Setting (46)

Parameters	Display	Setting Range		Step Size	Default Setting
		Min	Max		
NPS Trip Characteristic	I2> Characteristics	DEFT	INVERSE	-	DEFT
NPS Pickup Setting	I2> Pickup	0.10xlp	1.00xlp	0.01xlp	Disable
Time Multiple	K1 TD Multiplier	05sec	600sec	01sec	05sec
Definite Time Delay	I2> Deft time	00.1sec	600.0sec	00.1sec	00.2sec

(Table-3)

Earth Fault Protection Setting (These setting will not be applicable if sensitive earth fault protection is available)

Parameters	Display	Setting Range		Step Size	Default Setting
		Min	Max		
Earth characteristic	Curve Type	DEFT	EINV,VINV,LIINV,NINV1.3, NINV3.0, NINV0.6	-	DEFT
Earth pickup setting	Ie> Pickup	0.05xIn	2.5xIn	0.01xIn	Disable
Earth inverse timing	Ie> TD Multiplier	0.010	1.500	0.005	0.010
Earth definite timing	Ie> Deft Time	000.03sec	150.00sec	000.01sec	000.03sec
Earth hi-set pickup setting	Ie>> Pickup	0.50xIn	10.00xIn	0.05xIn	Disable
Earth hi-set definite timing	Ie>> Deft Time	00.02sec	20.00sec	00.01sec	00.02sec
Derived Earth current function	Ie_d> Function	Disable	Enable	-	Disable
Derived Earth current Pickup	Ie_d> Pickup	00.10xIn	15.00xIn	00.01xIn	01.00xIn
Derived Earth current Definite time	Ie_d> Deft Time	00.02sec	100.00sec	00.01sec	00.10sec
Derived Earth current Hi-set function	Ie_d>> Function	Disable	Enable	-	Disable
Derived Earth current Hi-set Pickup	Ie_d>> Pickup	00.10xIn	15.00xIn	00.01xIn	01.00xIn
Derived Earth Hi-set definite time	Ie_d>> Deft Time	00.02sec	100.00sec	00.01sec	00.10sec

(Table-4)

Over current Protection Setting (50/51P)

Parameters	Display	Setting Range		Step Size	Default Setting
		Min	Max		
I> pickup setting Stage-1	I>	0.20xlp	5.00xlp	0.01xlp	Disable
Phase trip characteristic Stage-1	PCURVE	DEFT	EINV,VINV,LIINV,NINV1.3, NINV3.0,NINV0.6	-	DEFT
ti> inverse timing Stage-1	ti>	0.01	1.5	0.005	0.010
t> definite timing Stage-1	t>	000.10sec	150.00sec	0.01sec	000.10sec
I>> pickup setting Stage-2	I>>	0.50xlp	40.00xlp	0.5xlp	Disable
t>> definite timing Stage-2	t>>	000.02sec	20.00sec	0.01sec	000.02sec
I>>> pickup setting	I>>> Pickup	00.50xlp	40.00xlp	0.50xlp	Disable
I>>> definite timing	I>>> Deft Time	00.02sec	20.00sec	0.01sec	00.02sec
SOTF Function	SOTF Function	Disable	Enable	-	Disable
SOTF Definite time	t_SOTF	0.02sec	0.50sec	0.01sec	0.02sec

(Table-5)

Circuit Breaker Failure Protection Setting (50BF)

Parameters	Display	Setting Range		Step Size	Default Setting
		Min	Max		
Circuit breaker failure protection time delay	CBFP Deft time	0.03sec	2.00sec	0.01sec	Disable

(Table-6)

Harmonic Blocking Setting

Parameters	Display	Setting Range		Step Size	Default Setting
		Min	Max		
Phase 2nd harmonic block	P2ndH	10%If	50%If	1%If	Disable
Earth 2nd harmonic block	E2ndH	10%If	50%If	1%If	Disable
Phase blocking time	tPHASE	00.00sec	20.00sec	00.10sec	00.00sec
Earth block time	tEARTH	00.00sec	20.00sec	00.10sec	00.00sec

(Table-7)

Under Current Protection Setting (37P)

Parameters	Display	Setting Range		Step Size	Default Setting
		Min	Max		
Under Current Pickup Setting	I<Pickup	0.20xlp	1.00xlp	0.01xlp	Disable
Under Current Timing	t<	001.00sec	260.00sec	000.01sec	002.00sec
Under Current Threshold	ThrsSet	0.50xlp	1.00xlp	0.05xlp	0.50xlp

(Table-8)

Sensitive Earth Over Current Setting (51SG)* (based on Ordering information)

Parameters	Display	Setting Range		Step Size	Default Setting
		Min	Max		
Phase Characteristics	Curve Type	DEFT	EINV, VINV, NINV1.3, LINV NINV3.0, NINV0.6	-----	DEFT
Ie> Current Setting	Ie> Pickup	0.002 Amp	1 Amp	0.001 Amp	0.1Amp
Ie> inverse timing	Ie> TD Multiplier	0.01 sec	1.5 sec	0.005 sec	0.1 sec
Ie> Definite timing	Ie> Deft Time	0.03 sec	150 sec	0.01 sec	0.03 sec
Ie>> Current Setting	Ie>> Pickup	0.002 Amp	1 Amp	0.001 Amp	0.1 Amp
Ie>> Definite timing	Ie>> Deft Time	0.03 sec	150 sec	0.01 sec	0.03 sec

(Table-9)

Cold Load Protection Setting (62 CLD)

Parameters	Display	Setting Range		Step Size	Default Setting
		Min	Max		
Mode of Trigger	MODE	Cold Load	DI/Inrush	-	Disable
Cold load time	tcold	00000sec	10000sec	00001sec	00020sec
Cold load pickup time	tclp	0001sec	3600sec	0001sec	0020sec
Inrush percentage setting	If2/If1	20%	100%	5%	30%

(Table-10)

DO Assignment Setting

S.No.	Parameters
1	OverCurrent Pickup
2	OverCurrent Trip
3	ShortCircuit Stage1 Pickup
4	ShortCircuit Stage1 Trip
5	ShortCircuit Stage2 Pickup
6	ShortCircuit Stage2 Trip
7	Earth Pickup
8	Earth Trip
9	Earth HiSet Pickup
10	Earth HiSet Trip
11	UnderCurrent Pickup
12	UnderCurrent Trip
13	Derived Earth Stage1 Pickup
14	Derived Earth Stage1 Trip
15	Derived Earth Stage2 Pickup
16	Derived Earth Stage2 Trip
17	Negative Phase Sequence current Pickup
18	Negative Phase Sequence current Trip
19	Thermal Relay
20	Thermal Alarm
21	Trip Circuit Supervision
22	Circuit Breaker Fault Protection
23	Broken Conductor Pickup
24	Broken Conductor Trip
25	Auto Recloser Close
26	Auto Recloser Lockout
27	Circuit Breaker Open
28	Circuit Breaker Close
29	Remote Trip1
30	Remote Trip2
31	Remote Trip3
32	Remote Trip4
33	Remote Trip5
34	Remote Trip6
35	Blocking Relay

(Table-11)

DI Assignment Setting

S.No.	Parameters
1	Circuit Breaker Close
2	Circuit Breaker Open
3	Circuit Breaker Ready
4	Remote Trip1
5	Remote Trip2
6	Remote Trip3
7	Remote Trip4
8	Remote Trip5
9	Remote Trip6
10	Group Toggling
11	Remote Reset
12	Oscilloscope Record Triggering
13	Cold Load
14	OverCurrent Blocking
15	ShortCircuit Stage1 Blocking
16	ShortCircuit Stage2 Blocking
17	Earth Blocking
18	Earth HiSet Blocking
19	UnderCurrent Blocking
20	Derived Earth Stage1 Blocking
21	Derived Earth Stage2 Blocking
22	Negative Phase Sequence Current Blocking
23	Thermal Blocking
24	Broken Conductor Blocking
25	Cold Load Pickup Blocking
26	Auto Recloser Blocking

(Table-12)

Function Reset Setting

S.No.	Parameters
1	OverCurrent Pickup
2	OverCurrent Trip
3	ShortCircuit Stage1 Pickup
4	ShortCircuit Stage1 Trip
5	ShortCircuit Stage2 Pickup
6	ShortCircuit Stage2 Trip
7	Earth Pickup
8	Earth Trip
9	Earth HiSet Pickup
10	Earth HiSet Trip
11	UnderCurrent Pickup
12	UnderCurrent Trip
13	Derived Earth Stage1 Pickup
14	Derived Earth Stage1 Trip
15	Derived Earth Stage2 Pickup
16	Derived Earth Stage2 Trip
17	Negative Phase Sequence current Pickup
18	Negative Phase Sequence current Trip
19	Thermal Relay
20	Thermal Alarm
21	Trip Circuit Supervision
22	Broken Conductor Pickup
23	Broken Conductor Trip
24	Auto Recloser Close
25	Remote Trip1
26	Remote Trip2
27	Remote Trip3
28	Remote Trip4
29	Remote Trip5
30	Remote Trip6
31	Blocking relay

(Table-13)

LED Assignment Setting

S.No.	Parameters
1	OverCurrent Pickup
2	OverCurrent Trip
3	ShortCircuit Stage1 Pickup
4	ShortCircuit Stage1 Trip
5	ShortCircuit Stage2 Pickup
6	ShortCircuit Stage2 Trip
7	Earth Pickup
8	Earth Trip
9	Earth HiSet Pickup
10	Earth HiSet Trip
11	UnderCurrent Pickup
12	UnderCurrent Trip
13	Derived Earth Stage1 Pickup
14	Derived Earth Stage1 Trip
15	Derived Earth Stage2 Pickup
16	Derived Earth Stage2 Trip
17	Negative Phase Sequence current Pickup
18	Negative Phase Sequence current Trip
19	Thermal Relay
20	Thermal Alarm
21	Trip Circuit Supervision
22	Circuit Breaker Fault Protection
23	Broken Conductor Pickup
24	Broken Conductor Trip
25	Auto Recloser Close
26	Auto Recloser Lockout
27	Circuit Breaker Open
28	Circuit Breaker Close
29	Remote Trip1
30	Remote Trip2
31	Remote Trip3
32	Remote Trip4
33	Remote Trip5
34	Remote Trip6

(Table-14)

Broken Conductor Protection Setting (46BC)

Parameters	Display	Setting Range		Step Size	Default Setting
		Min	Max		
NPS to PPS Ratio	I2/I1 Ratio	0.10	0.50	0.01	Disable
Definite Time for broken conductor fault	(BC)Deft Time	0.05sec	20.00sec	0.01sec	0.10sec

(Table-15)

Auto Recloser Setting (79)

Parameters	Display	Setting Range		Step Size	Default Setting
		Min	Max		
Blocking of Auto-recloser	ENABLE	NO	YES	-	NO
Set Dead Time-1	D1	000.20sec	300.00sec	000.01sec	000.20sec
Set Dead Time-2	D2	000.2sec	300.00sec	000.01sec	000.20sec
Set Dead Time-3	D3	000.2sec	300.00sec	000.01sec	000.20sec
Set Dead Time-4	D4	000.2sec	300.00sec	000.01sec	000.20sec
Set Reclaim Time	t _R	000.2sec	300.00sec	000.01sec	000.20sec
Cycle I>	I> Cycle	2	4/Disable	1	2
Cycle I>>	I>> Cycle	2	4/Disable	1	2
Cycle I>>>	I>>> Cycle	2	4/Disable	1	2
Cycle Ie>	Ie> Cycle	2	4/Disable	1	2
Cycle Ie>>	Ie>> Cycle	2	4/Disable	1	2
Trip sense time	t _{TripSns}	0.05sec	2.00sec	0.01sec	0.05sec

(Table-16)

Thermal Over-load Setting (49)

Parameters	Display	Setting Range		Step Size	Default Setting
		Min	Max		
Thermal memory mode	TH_Mode	M1	M2/M3	-	M1
Permissible basic current	I _b	0.20xI _p	4.00xI _p	0.02xI _p	Disable
Constant	TH_Const	0.50	2.00	0.01	1.00
Heating time constant	TH_Heat	000.5min	180.0min	000.1min	000.5min
Cooling constant	TH_Cold	1.00xTh	8.00xTh	0.01xTh	1.00xTh
Thermal alarm	Alarm_R	20%	99%	1%	20%
NPS weighting factor	I2_Wght	0.05	2.50	0.05	2.50
Thermal reset	TH_Reset	00%	99%	1%	70%
Thermal trip characteristics	TH_Char	Th1	Th2	-	Th1

(Table-17)

Erase Counter Record Setting

Parameters	Display	Setting Range		Step Size	Default Setting
		Min	Max		
Trip Count	Trip Counter	NO	YES	-	NO
Thermal Memory Reset	Thermal m/m Reset	NO	YES	-	NO
Erase Events	Events Erase	NO	YES	-	NO
Erase Faults	Faults Erase	NO	YES	-	NO
Oscillator Record Erase	Osc. Record Erase	NO	YES	-	NO
Energy Counter Erase	EnergyCounterRst	NO	YES	-	NO

Common Setting

(Table-18)

These are the setting's common for all the protections:

Parameters	Display	Setting Range		Step Size	Default Setting
		Min	Max		
Phase Rated Current	Ip	1.00Amp	5.00Amp	-	1.00Amp
Earth Rated Current	In	1.00Amp	5.00Amp	-	1.00Amp
Phase CT Ratio	Ph CTRatio	001	9999	1	001
Earth CT Ratio	E CTRatio	001	9999	1	001
Nominal Frequency	FREQ (Fn)	50Hz	60Hz	10Hz	50Hz
Phase Rotation	Ph Rotation	1-2-3	1-3-2	-	1-2-3
Fault Message Status	[F]Status	Disable	Enable	-	Disable
Service Mode	Servc Mode	Disable	Enable	-	Disable

(Table-19)

Oscilloscope (Disturbance) Record

Parameters	Display	Setting Range		Step Size	Default Setting
		Min	Max		
Oscilloscope recording selection	OSC. RECORD	NO	YES	-	NO
Pre-fault cycle	PRE CYCLE	002C	298C	1C	002C
Post-fault cycle	POST CYCLE	002C	298C	1C	002C
Triggering mode	TRIGGER MODE	PK-UP	PK-UP/TRIP/DI/ Anyone	-	PK-UP

(Table-20)

Communication

RS-485 Communication		Default Setting
Baud rate selection (programmable)	9600 / 19200 / 38400 bps	9600 bps
Parity selection (programmable)	EVEN / ODD / NONE	NONE
Stop bit	1 Bit	1 Bit
Data bit	8 Bit data	8 Bit data
Remote address (programmable)	254	1
Cable required for Interface	Two wire twisted shielded cable	-----

(Table-21)

USB Communication	
Protocol	CSE Proprietary Protocol: available with front software
Baud rate	115200 bps
Cable required for Interface	USB cable type (Mini - B to A)

(Table-22)

15.0 Technical Data

Measuring Input

Rated Data	Rated current I_n : 1A or 5A Rated frequency F_n : 50 Hz/60Hz
Drop out to Pickup Ratio	>96%
Reset Time	30mSec
AC Current VA Burden	At $I_n=1A$ <0.1 VA At $I_n=5A$ <0.2 VA
AC Voltage VA Burden	At $V_n=110V$ <0.06 VA
Thermal withstand capability in current circuit	Dynamic current withstand for 1 Sec : $100 \times I_n$ for 10 Sec : $30 \times I_n$ continuously : $4 \times I_n$

(Table-23)

Trip Time Accuracy for Current Protections

Parameters	Accuracy
Trip time accuracy for protections except NPS & REF	$\pm 30\text{mSec}$ OR $\pm 5\%$ (whichever is higher)
Trip time accuracy for NPS	$\pm 60\text{mSec}$ OR $\pm 7.5\%$ (whichever is higher)
Trip time accuracy for REF	Corresponding to error generated by inaccuracies in each phase $\pm 30\text{mSec}$ OR $\pm 5\%$ (whichever is higher)

(Table-24)

Trip Time Accuracy for Voltage Protections

Parameters	Accuracy
Trip time accuracy for voltage protections	Inaccuracy in Trip Timing in reference to $\pm 2\%$ error in measured voltage OR $\pm 30\text{mSec}$

(Table-25)

Measurement Accuracy

Parameters	Range	Frequency Range	Accuracy
Current in Ampere	$1.0-30 \times I_n$	50-60Hz	Less than $\pm 2\%$
Voltage	$5-150\% U_n$	50-60Hz	Less than $\pm 2\%$
Power	—	—	Less than $\pm 5\%$
Power Factor	—	—	Less than ± 0.02
Frequency	$F_n \pm 10$ Hz	40-70 Hz	Less than ± 0.01 Hz

(Table-26)

Trip Contact Rating

Contact rating	
Contact relay	Dry contact Ag Ni
Make current	Max. 30A & carry for 3S
Carry capacity	8A continuous
Rated voltage	250V AC / 30V DC
Breaking characteristics	
Breaking capacity AC	1500VA resistive 1500VA inductive (PF=0.5) 220V AC, 5A(cos ϕ =0.6)
Breaking capacity DC	135V DC, 0.3A (L/R=30ms) 250V DC, 50W resistive or 25W inductive (L/R=40ms)
Operation time	<10ms
Durability	
Loaded contact	10,000 operation minimum
Unloaded contact	30,000 operation minimum

(Table-27)

Auxiliary Supply

Rated auxiliary voltage UH	For 'L' Model	18V-150V DC
	For 'H' Model	80V-280V AC / 90V-300V DC
Rated supply for digital input	Normal Voltage UN	40V-280V AC (Active)
	For 'H' Model	40V-300V DC (Active)
		<25V AC (Inactive)
	<25V DC (Inactive)	
Power consumption	Normal Voltage UN	18V - 150V DC (Active)
	For 'L' Model	<10V DC (Inactive)
Power consumption	Quiescent approx. 3W	Operating approx. <7W

(Table-28)

Common Data

Dropout ratio	> 96%
Relay reset time	30 ms
Minimum operating time	30 ms
Transient overreach at instantaneous operation	$\leq 5\%$

(Table-29)

Date & Time Setting

Parameters	Display	Setting Range		Step Size	Default Setting
		Min	Max		
Date	DATE	1	31	1	---
Month	MONTH	Jan	Dec	1	---
Year	YEAR(2000 Y)	00	99	1	---
Day	DAY	SUN	SAT	1	---
Hour	HOUR	0	23	1	---
Minute	MIN	0	59	1	---
Second	SEC	0	59	1	---

(Table-30)

16.0 Standards

Type Test

F1	Functional Tests	Internal Design	Performance in line with Specification & Standards
		Specifications & IEC60255-6 IEC60255-3	Pickup/Drop down/Power consumption in Current/Voltage/Aux Supply/Trip timing accuracy: OC/ Directional/NPS/Thermal/OV/Zero Seq/Over Power/ freq/Rate of change of Freq

Climatic Test

C1	Temperature Dry Cold (Relay operational)	IEC 60068-2-1	-20 deg C, 96 hours
C2	Temperature Dry Cold Transportation & Storage	IEC 60068-2-1	-25 deg C, 96 hours
C3	Temperature Dry Heat (Relay operational)	IEC 60068-2-2	55 deg C, 96 hours
C4	Temperature Dry Heat Transportation & Storage	IEC 60068-2-2	70 deg C, 96 hours
C5	Damp Heat Test (Relay operational)	IEC 60068-2-3	95% @ +55 / +25 deg C, 6 cycle (12hr + 12hr each)

Enclosure

C6	Enclosure	IEC 529	Front IP54 (Dust5x + Water x4)
----	-----------	---------	--------------------------------

Mechanical Test

Relay Operational

M1	Vibration response / Endurance test	IEC 60255-21-1	Class I Vibration response (Relay operational) 10Hz~150 Hz - peak displacement 0.035 mm below 58/60 Hz, 0.5 g above, 1 sweep cycle in each axis Vibration endurance (Relay de-energised) 10 Hz~150 Hz 1g, 20 sweep cycles in each axis
M2	Shock response / Withstand Test	IEC 60255-21-1	Class I Shock response (Relay operational) 5g 11mS 3 pulse in each axis Shock withstand (Relay de-energised) 15g 11mS 3 pulses in each axis
M3	Bump	IEC 60255-21-1	Bump (Relay de-energised) 10g 16mS 1000 pulses in each axis
M4	Seismic	IEC 60255-21-3	Class I Method A single axis sine sweep 1 Hz~35 Hz~below 8/9 Hz 3.5 mm peak displacement horizontal axis, 1.5 mm vertical axis above 8/9 Hz 1g horizontal, 0.5 g vertical 1 sweep cycle in each axis

Electrical Test			
E1	Insulation Resistance >100MΩ	IEC 60255-5	500V DC, 5 sec between all terminals & case earth, between terminals of independent circuits including contact circuits and across open contacts
E2	DC & AC Supply Voltage (Relay operational)		IEC60255-6 Voltage range, upper & lower limit continuous withstand, ramp up & down over 1 minute
E3	Voltage Dips, Short Interruptions & Voltage variations immunity (Relay operational)	IEC 1000-4-11	IEC60255-113 Dips & 3 Interruptions at 10 sec intervals of duration between 10mS and 500mS at zero crossings & at other points on wave Variation: 100% to 40% over 2s, hold for 1s, return to 100% over 2s
E4	Ripple in DC supply (Relay operational)	IEC 60255-11	12% AC ripple
E5	Dielectric Test (Relay de-energised) No breakdown or flash over Test voltage 45-65 Hz sinusoidal or with DC voltage at 1.4x the stated AC values	IEC 60255-5	2.0 KV @ 1min All circuit to Earth / Between IP & OP except communication terminals
E6	High Voltage Impulse (Relay de-energised)	IEC 60255-5	5 kV peak 1.2/50uS, 0.5 J-3 positive, 3 negative between all terminals to case earth between independent circuits
E7	VT Input Thermal Withstand		1.5xVn, continuous
E8	CT Input Thermal Withstand		250xIn half wave 100xIn for 1 second 30xIn for 10 second 4xIn continuously
E9	Contact performance & endurance tests	IEC 60255-14,15 IEC 60255-23	

Electro-magnetic Compatibility

R1	Electrical fast Transient/Burst (Relay operational)	IEC 60255-22-4 IEC 60100-4-4	Class IV ± 4.0 kV All Circuits. Pulse 5/50msec / Duration 15msec / Period: 300msec/ Pulse Freq: 5KHz / 2KV at I/O
R2	HF Disturbance Test (Oscillatory Waves) 1 MHZ Burst (Relay operational)	IEC 60255-22-1	Class III Longitudinal 2.5 kV peak, 2sec between independent circuits & case earth
R3	Electrostatic Discharge (Relay operational)	IEC 60255-22-2 IEC 61000-4-2	Class III 8kV air discharge, 6KV contact No of Discharge : 10 both polarities at 1 sec intervals
R4	Conducted Disturbance RF fields (Relay operational)	IEC 61000-4-6 IEC 60255-22-6	0.15 to 80 MHZ (Level-3) Severity Level 10V RMS + sweeps 0.05-0.15 MHZ & 80-100 MHZ
R6	Radiated RF E-M field immunity test (Relay operational)	IEC 60255-22-3 IEC 61000-4-3	Class III Test method A + sweep 80-1000 MHZ or IEC 1000-4-3 80-1000 MHZ severity 10 V/m 80% modulated 1 kHz
R7	Surge Immunity capacitively coupled (Relay operational)	IEC 61000-4-5 Class 5 Test level 4 IEC 60255-22-5: 2008 Latest: IEC 60255-26:2013	Short circuit combination wave generator 1.2 uS/50 uS open circuit repetition rate 1 per minute Power supply, CT & VT circuits – 4kV common mode 2 Ohm source 2kV differential mode 12 Ohm source
R8	Power Frequency Magnetic Field (Relay operational)	IEC 61000-4-8	100 A/m for 1 minute in each of 3 axes
R14	Conducted & Radiated RF Interference Emission (Relay operational)	EN55011 IEC 60255-25	CISPR11 / Class A
R15	Power Frequency, conducted common mode	IEC 1000-4-16 IEC 60255-22-7	D.C. to 150 kHz Test Level 4 300V at 16 2/3 Hz and 50 Hz

17.0 Recommended Terminal Lugs Specifications

Term Blocks	Type/Cable Specifications
Current Inputs	Ring Type lug / 2.5mm ² or 4 mm ² control cable
Auxiliary Supply	Pin Type lug / 1.5 mm ² / 2.5 mm ² control cable
Rear Comm. Port	Pin Type lug / 1.5 mm ² / 2.5 mm ² control cable
Front Comm. Port	USB, Type mini - B to A
Binary Input	Pin Type lug / 1.5mm ² / 2.5mm ² control cable
Binary Output	Pin Type lug / 4.0mm ² control cable
Earth Connections	Ring Type / 2.5mm ² or 4 mm ² contact cable



**USB Cable required for Front communication
(Mini-Type B to A)**



OTG Cable required for Pen Drive Interface



18.0 Relay Conn. Diagram-F200 (H)

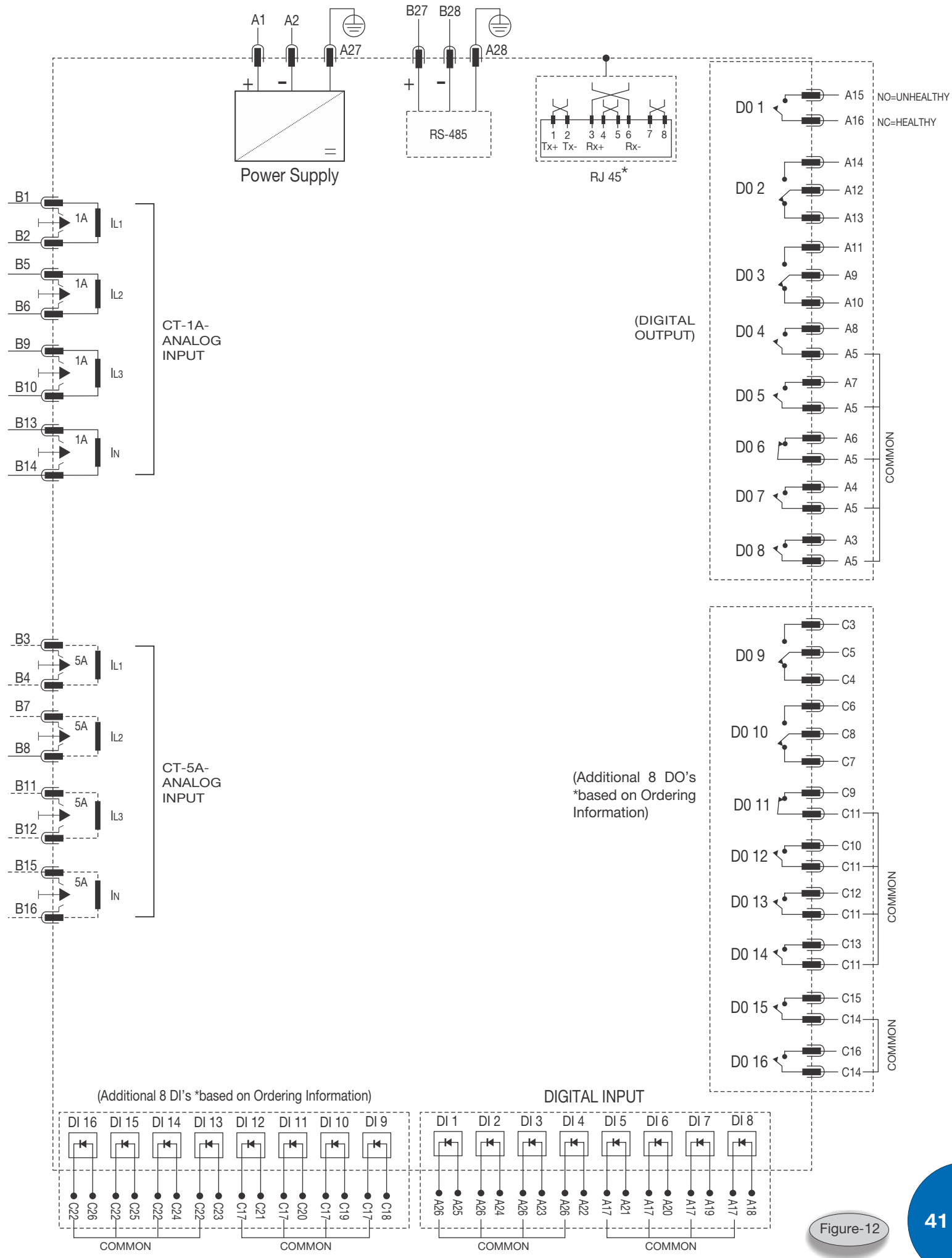

Figure-12

19.0 Terminal Description

Terminal No.	Terminal Description	Contact Details
A1	: Auxiliary Supply (+)	
A2	: Auxiliary Supply (-)	
A3-A5	: Digital Output-8 (DO-8)	: (NO-COMMON)
A4-A5	: Digital Output-7 (DO-7)	: (NO-COMMON)
A6-A5	: Digital Output-6 (DO-6)	: (NC-COMMON)
A7-A5	: Digital Output-5 (DO-5)	: (NO-COMMON)
A8-A5	: Digital Output-4 (DO-4)	: (NO-COMMON)
A11-A9-A10	: Digital Output-3 (DO-3)	: (NO-COMMON-NC)
A14-A12-A13	: Digital Output-2 (DO-2)	: (NO-COMMON-NC)
A15-A16	: Digital Output-1 (DO-1)	: (NO-COMMON)
A18-A17	: Digital Input-1 (DI-8)	
A19-A17	: Digital Input-2 (DI-7)	
A20-A17	: Digital Input-3 (DI-6)	
A21-A17	: Digital Input-4 (DI-5)	
A22-A26	: Digital Input-5 (DI-4)	
A23-A26	: Digital Input-6 (DI-3)	
A24-A26	: Digital Input-7 (DI-2)	
A25-A26	: Digital Input-8 (DI-1)	
B1-B2	: CT Terminal for Phase current (1A) input in L1 Phase	
B5-B6	: CT Terminal for Phase current (1A) input in L2 Phase	
B9-B10	: CT Terminal for Phase current (1A) input in L3 Phase	
B13-B14	: CT Terminal for Earth current input (1A)	
B3-B4	: CT Terminal for Phase current (5A) input in L1 Phase	
B7-B8	: CT Terminal for Phase current (5A) input in L2 Phase	
B11-B12	: CT Terminal for Phase current (5A) input in L3 Phase	
B15-B16	: CT Terminal for Earth current input (5A)	
B27	: RS-485 MODBUS (+)	
B28	: RS-485 MODBUS (-)	
A28	: Earth (RS-485)	
A27	: Earth (Aux. Supply)	
C3-C5-C4	: Digital Output-9 (DO-9)	: (NO-COMMON-NC)
C6-C8-C7	: Digital Output-10 (DO-10)	: (NO-COMMON-NC)
C9-C11	: Digital Output-11 (DO-11)	: (NO-COMMON)
C10-C11	: Digital Output-12 (DO-12)	: (NC-COMMON)
C12-C11	: Digital Output-13 (DO-13)	: (NO-COMMON)
C13-C11	: Digital Output-14 (DO-14)	: (NO-COMMON)
C15-C14	: Digital Output-15 (DO-15)	: (NO-COMMON)
C16-C14	: Digital Output-16 (DO-16)	: (NO-COMMON)
C18-C17	: Digital Input-9 (DI-9)	
C19-C17	: Digital Input-10 (DI-10)	
C20-C17	: Digital Input-11 (DI-11)	
C21-C17	: Digital Input-12 (DI-12)	
C23-C22	: Digital Input-13 (DI-13)	
C24-C22	: Digital Input-14 (DI-14)	
C25-C22	: Digital Input-15 (DI-15)	
C26-C22	: Digital Input-16 (DI-16)	

20.0 CT Connection Diagram

CT Schemes Holmgreen Residual CT's Connection for 1A

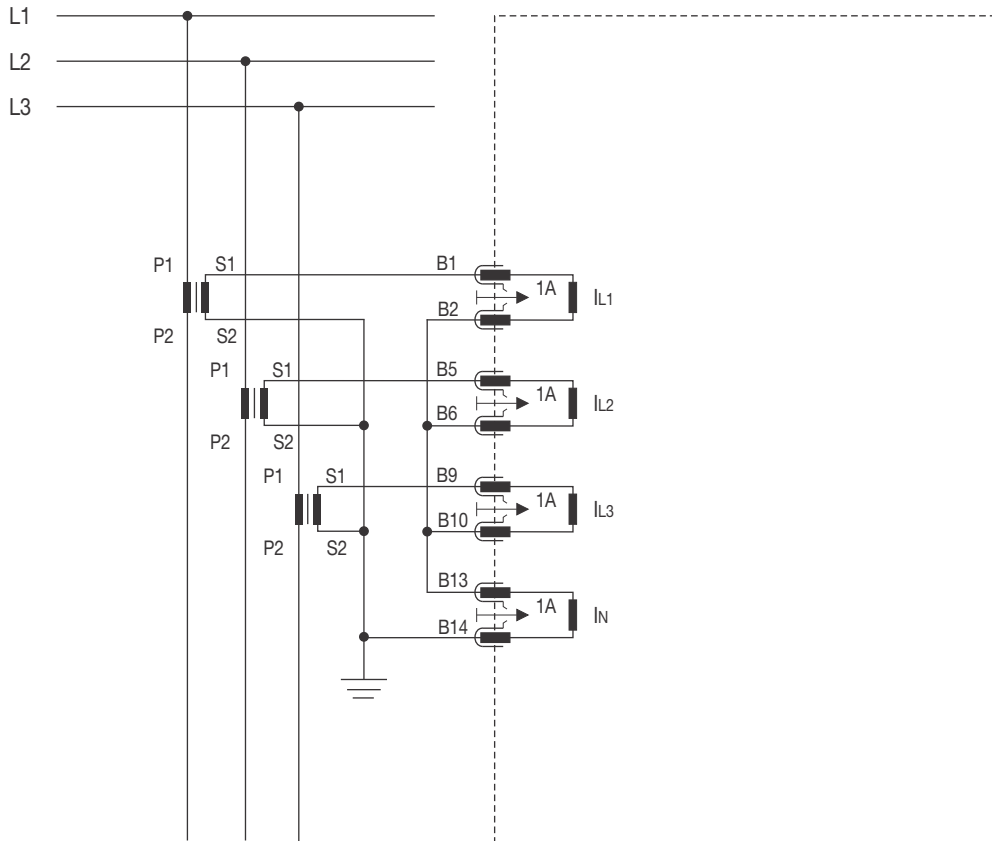

Figure-13

21. CT Connection Diagram

CT Schemes Holmgreen Residual CT's Connection for 5A

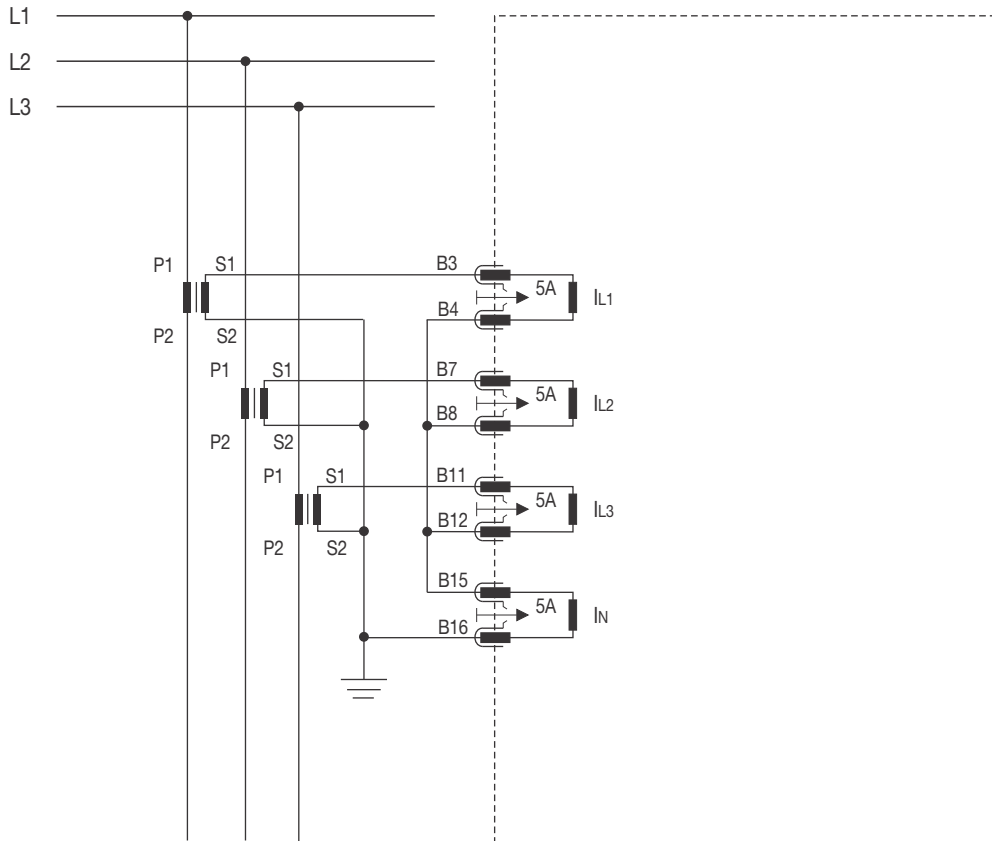
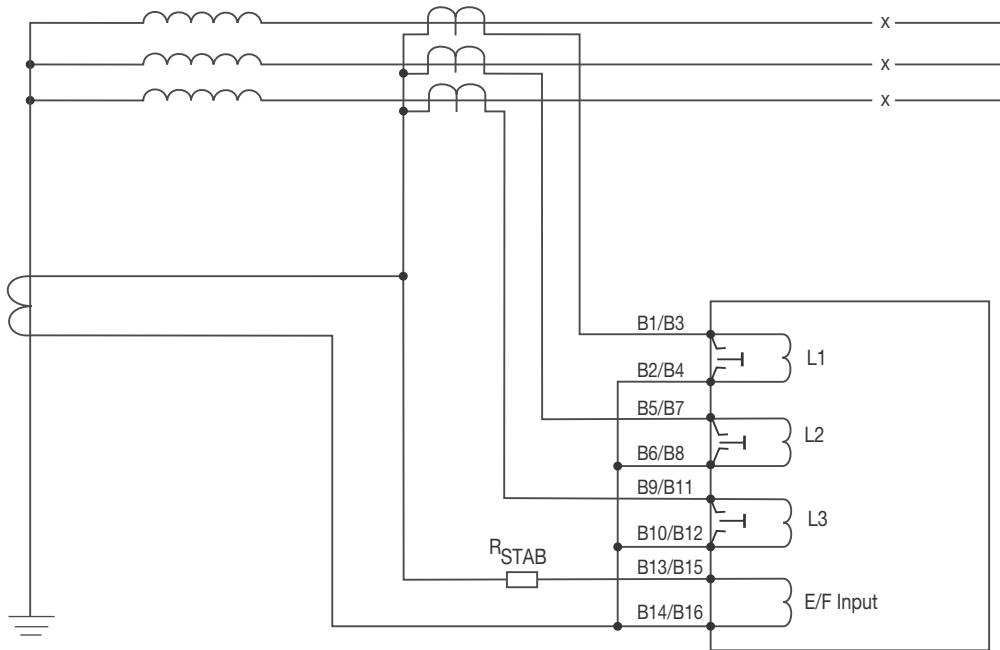

Figure-14

22.0 Connection Scheme for Restricted Earth



CT Connection Diagram for High Impedance REF Application

Figure-15

23.0 Trip Circuit Supervision Diagram

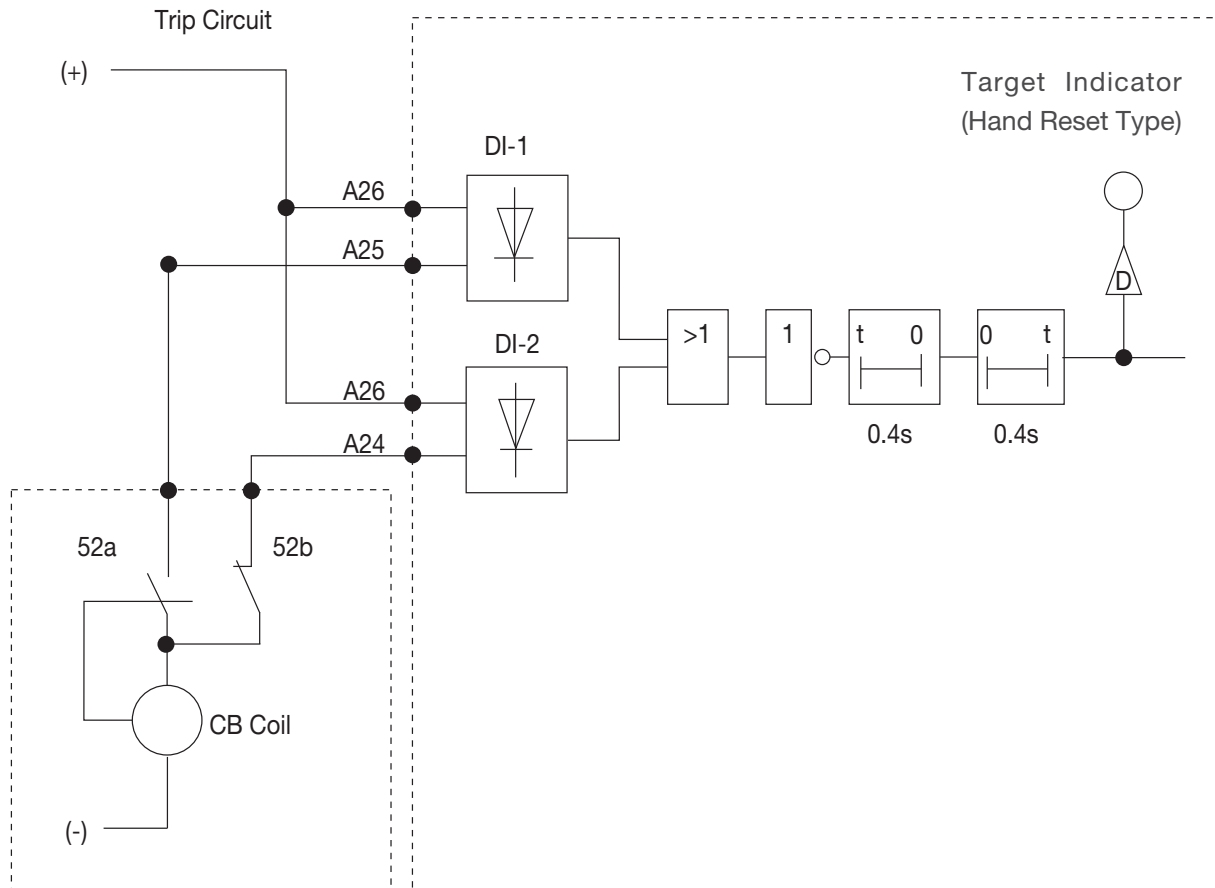

(Trip Circuit Supervision Function)

Figure-16

24.0 Dimensional Details

All the dim are in mm (Gen. Tol $\pm 1.0\text{mm}$)

Front View

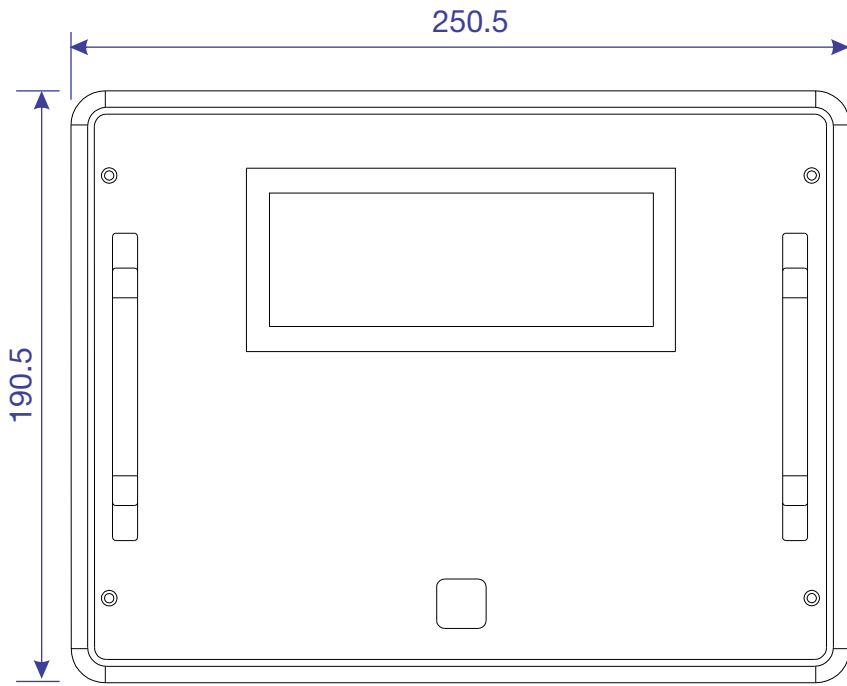

Figure-17

Top View

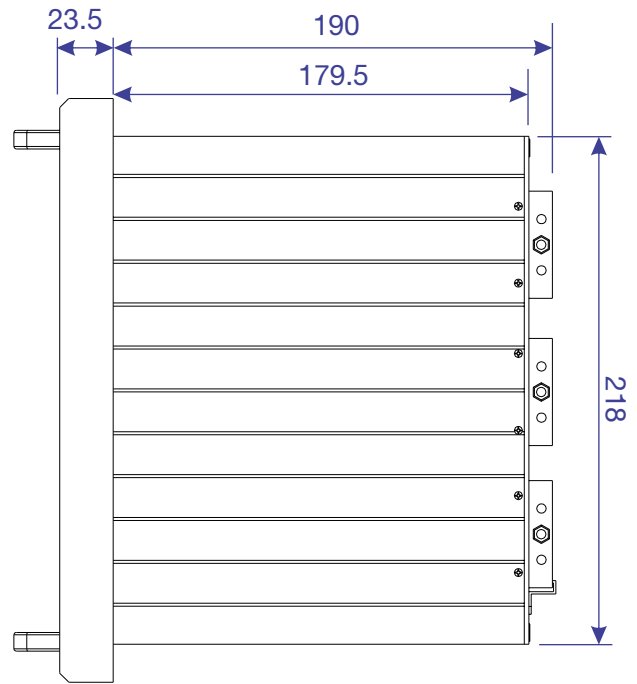

Figure-18

Side View



Figure-19

Panel mounting of the Relay

for Panel mounting

Screw	:	M4x12mm
Qty	:	8 Nos.

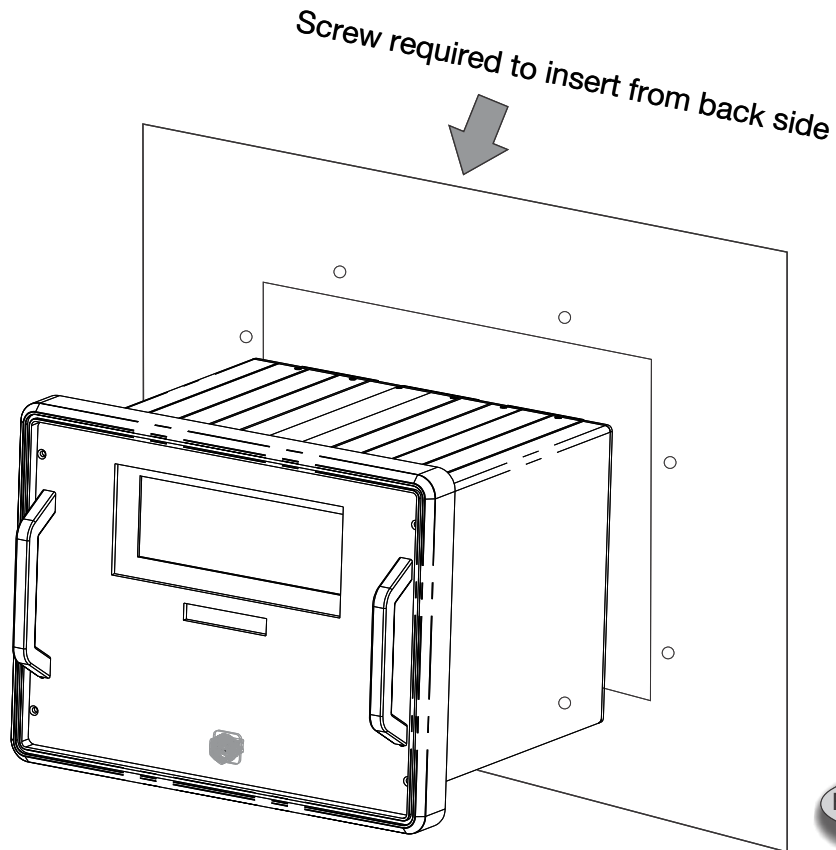

Figure-20

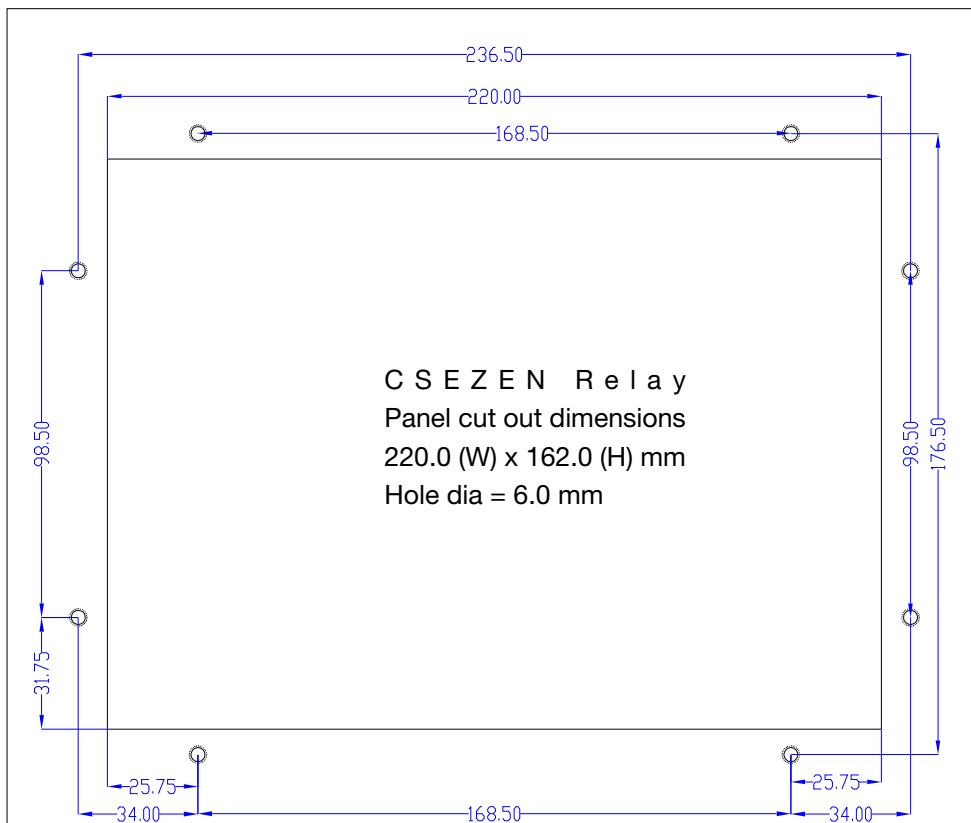

Figure-21

Different views of the Relay

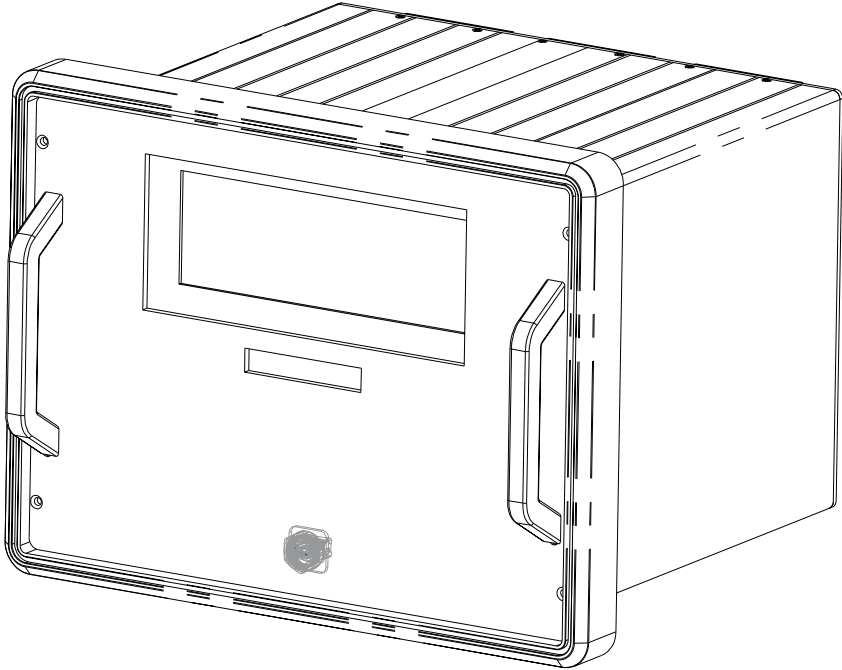

Figure-22

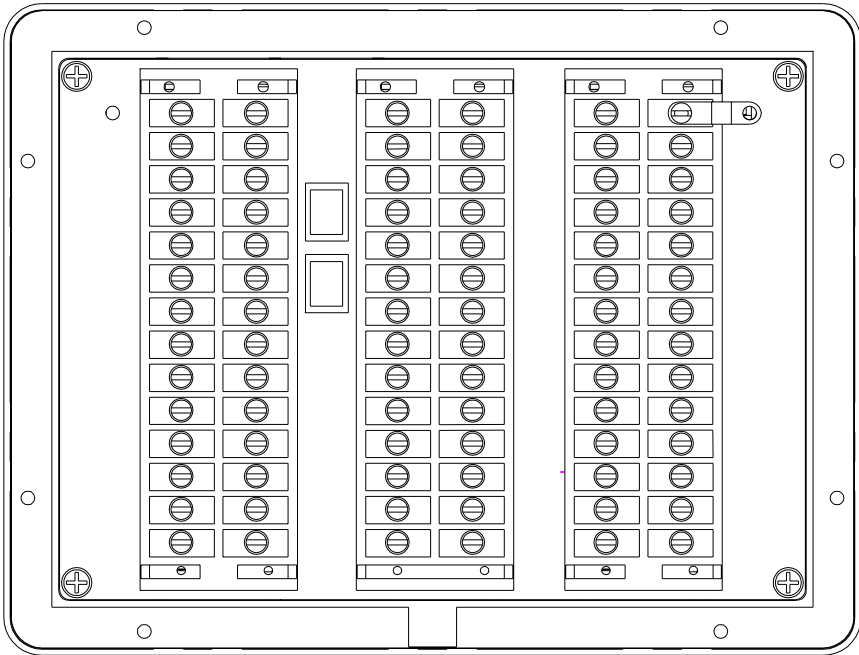

Figure-23

25.0 Ordering Information

CSEZEN - F - 200 - N - x - D - x - SEH

DIGITAL I O CARD	
8 DI / DO	0
16 DI / DO	1

AUXILIARY SUPPLY	
18V-150V DC	L
80V-280V AC / 90V-300V DC	H

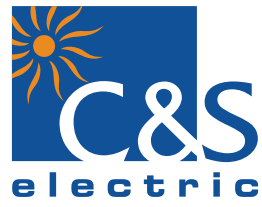

Issue Date : 07.07.16
Rev. No : 05
Rev. Date : 15.01.18

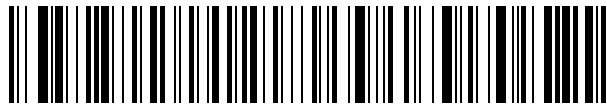

CSEZEN- E Cat a l o g u e

Revision History

S.No.	Rev.No.	Details	Date
01	01	Inclusion of Front Photograph & dimension Details	02.09.16
02	02	Insertion of Lugs photo on page 40	03.11.16
03	03	Included improved panel cut out dimension.	27.02.17
04	04	Removed l>>>> setting from setting ranges etc.	05.04.17
05	05	Include “Healthy, unhealthy” in connection diagram on page 41	15.01.18